

Promat

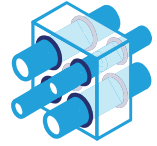

Penetration seal

PROMASEAL[®] Bulkhead Sealer System

Installation guide



www.promat.com

etex inspiring ways
of living

PROMASEAL® Bulkhead Sealer System

Made using high density mineral wool that is protected with a robust ablative coating to both faces.

PROMASEAL® Bulkhead Sealer batts are a simple and economical way to fire rate voids and when combined with Promat's many other fire stopping systems can protect a wide range of penetration types and sizes.

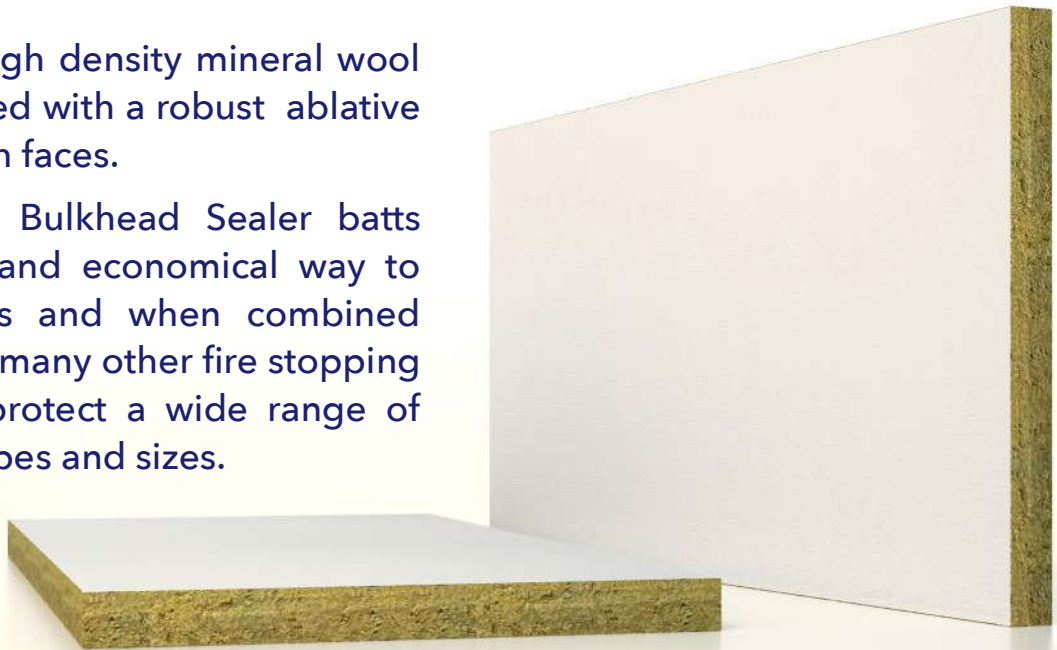

Properties

- Approved to AS1530.4(2014) and AS4072.1
- Manufactured to ISO2001:2008
- Size: 1200 x 600 x 50mm
- Coating: White Ablative
- Density: > 160kg/m³
- Packaging: Individual wrapped in Promat branded plastic film
- Acoustics: Rw (Ctr) : 29 (-3)
- FRL: up to -/180/180

Benefits

- Economical
- Easy install
- Up to 3 hours fire rating
- Floor and wall penetrations

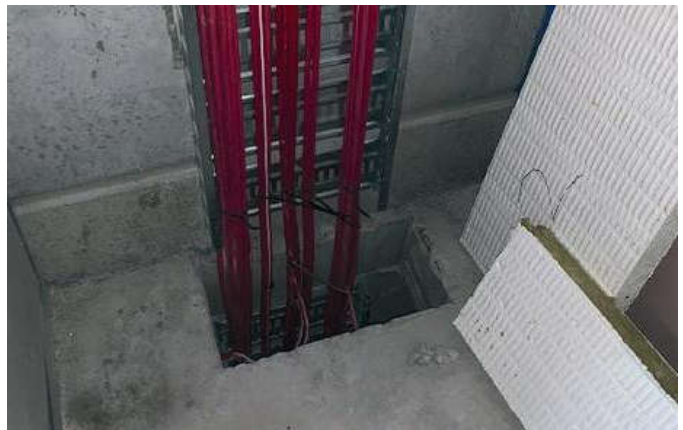
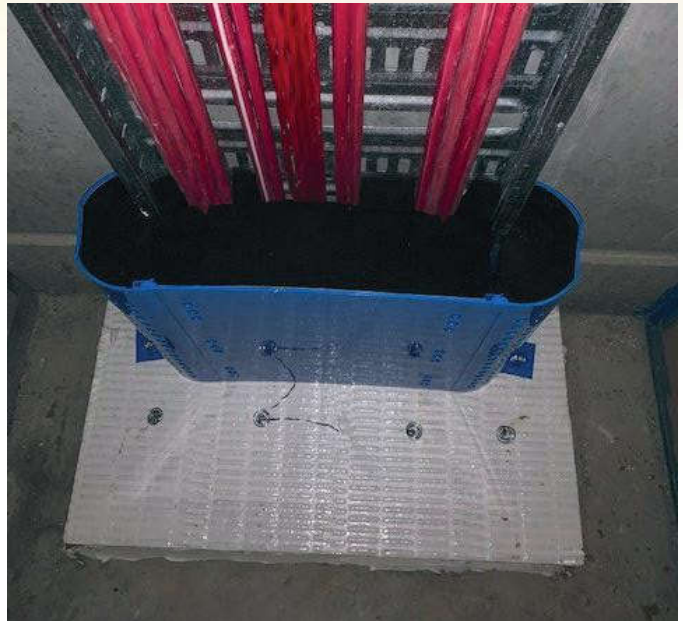

Penetrations Approved

- uPVC
- HDPE
- PVC Conduits
- Metal pipes lagged and bare
- PEX
- Cables (electrical/telco/optical)
- Cable Trunking

Approved substrates

- Concrete Slabs
- Plasterboard walls
- Speedpanel
- KOROK
- Hebel/AAC
- Masonry

Please refer to the relevant assessment report for installation specifics

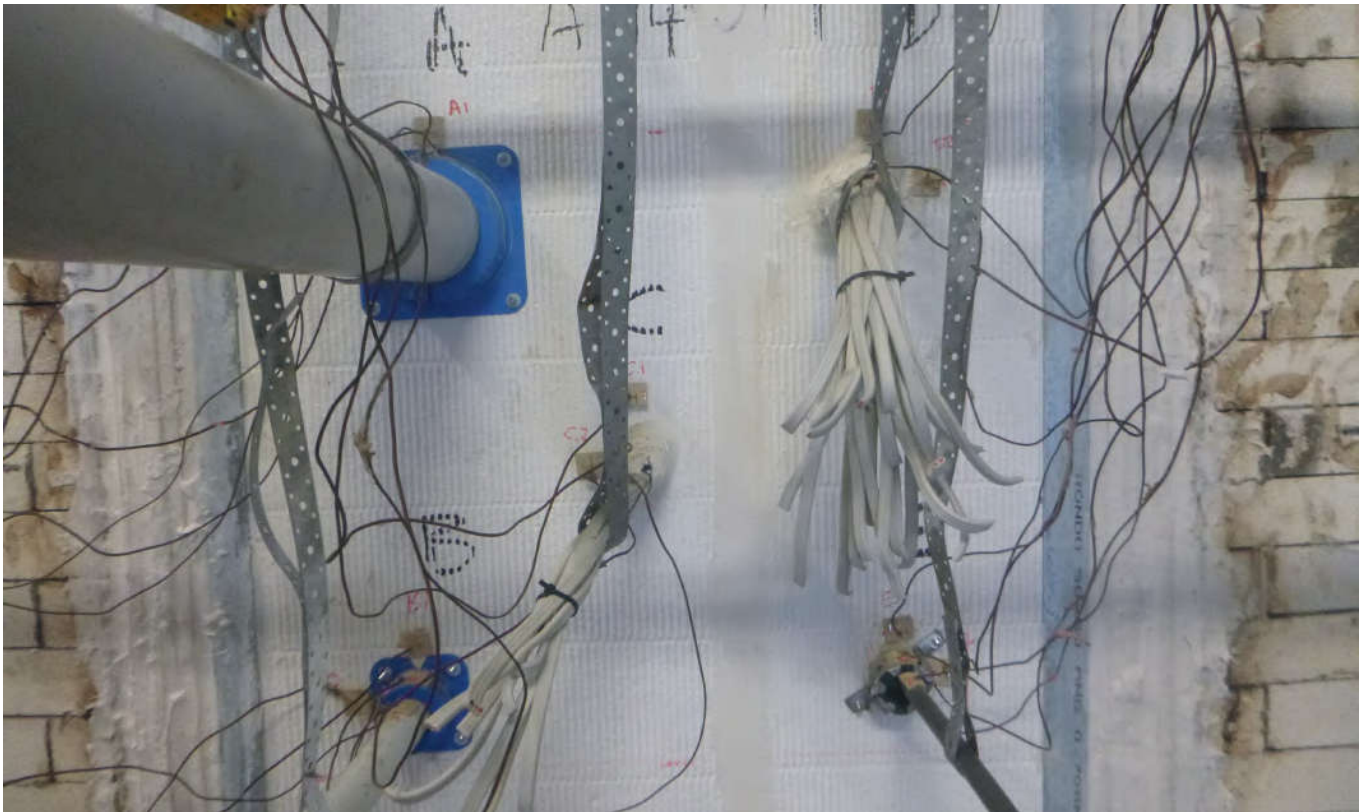

TESTED WITH

1. PROMASEAL®-A Acrylic (405932)
2. PROMASEAL® Retrofit collars (78257-78256)
3. PROMASEAL® Wall Collars (78271-78269)
4. PROMASEAL® Conduit Collars (78230)
5. PROMASEAL® Supawrap (4070360)
6. PROMASHEILD®

Approved Opening Sizes

Walls:

Method 1

Min. 116mm Plasterboard (2 x 13mm each face), Concrete, Masonry, AAC . 2 layers installed within opening

- Up to 600mm (H) x Up to 1500mm (W) or
- Up to 1000mm (H) x any width up 1m² or
- Up to 500mm (H) x any length



Method 2

Min. 116mm Plasterboard (2 x 13mm each face), Concrete, Masonry or Min. 75mm AAC min. One Layer installed on each face of wall

- Up to 550mm (H) x 450mm (W)



Method 3

Min. 75mm AAC. Min 78mm Speedpanel Concrete, Masonry. One Layer on face. One Layer inside opening

- Up to 550mm (H) x 450mm (W)



Method 4:

Min. 90mm Plasterboard (1 x 13mm each face), Masonry, Concrete. One Layer inside opening

- Up to 600mm (H) x Up to 1200mm (W)



Method 5

Min. 116mm Plasterboard (1 x 13mm each face), Masonry or Concrete One Layer installed on each face of wall

- Up to 550mm (H) x 450mm (W)



Approved Opening Sizes

Floors

Method 1

Min. 120mm Concrete. 2 layers installed within opening

- Up to 800mm (W) x Up to 1500mm (L) with angles or
- Up to 500mm (W) x Up to 1000mm (L) no angles or
- Up to 600mm (W) x any length. Angles at 600mm centres
- Up to 300mm (W) x any length. No additional supports



Method 2

Min. 120mm Concrete. 1 layer installed within opening, 1 layer on top of slab (100mm overlap)

- Up to 800mm (W) x Up to 1500mm (L) with angles or
- Up to 500mm (W) x Up to 1000mm (L) no angles or
- Up to 600mm (W) x any length. Angles at 600mm centres
- Up to 300mm (W) x any length. No additional supports



Method 3

Min. 120mm Concrete. 2 layers on top of slab (100mm overlap)

- Up to 800mm (W) x Up to 1500mm (L)
- Up to 600mm (W) x any length.

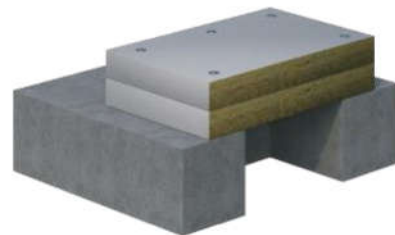

Installation Method

Please see safety data sheet (SDS) for appropriate personal protection equipment (PPE).

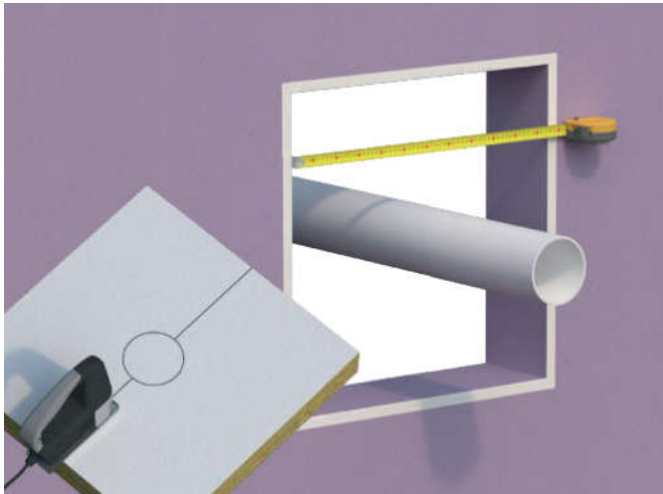

1. Measure opening and cut PROMASEAL® Bulkhead Batt to suit the opening and services.



2. Apply PROMASEAL®-A Acrylic Sealant to the cut surface and the mating substrate.

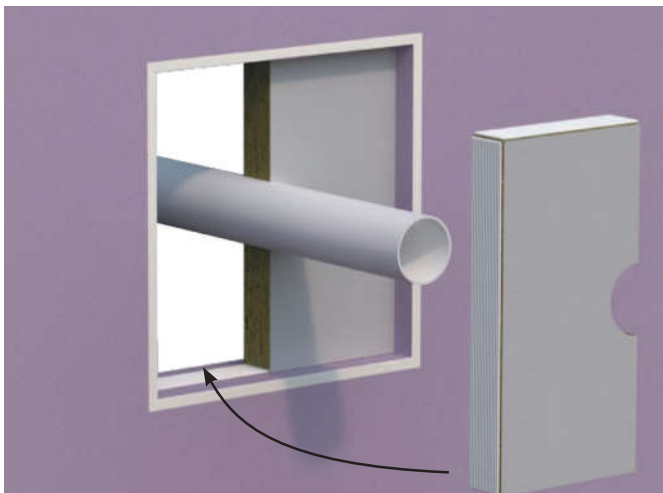

3. Assemble batt into the opening. Noting any additional support requirements as listed in the relevant report.

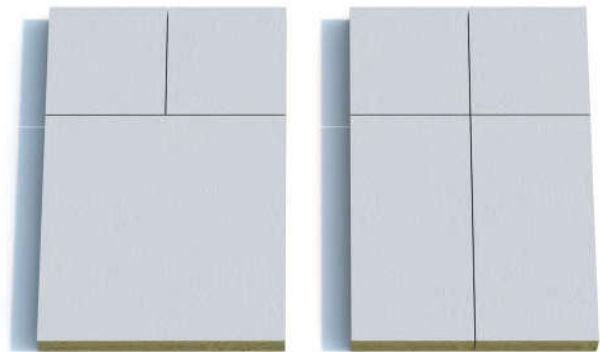

4. Joints between layers should be staggered so that no straight through gaps occur in the filled of the batt. Do not have cross junctions of butt joints in a single layer.

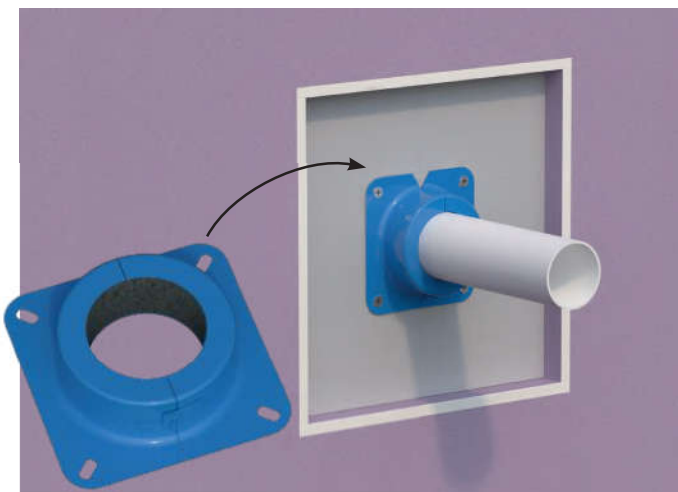

5. Fire stop penetrations in accordance with the relevant report.



6. Apply sticker to finished penetration.

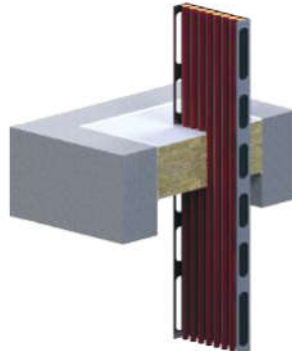
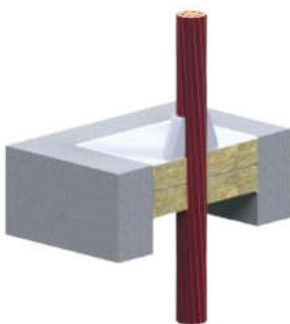
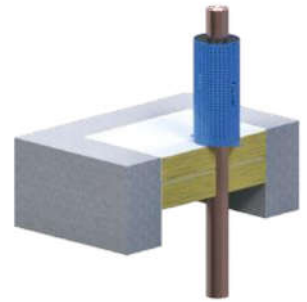
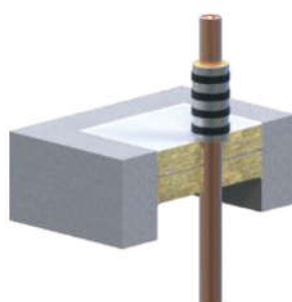
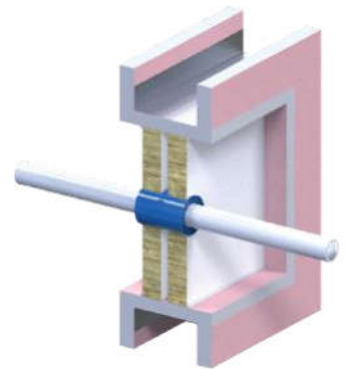
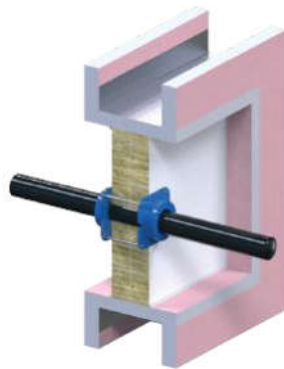
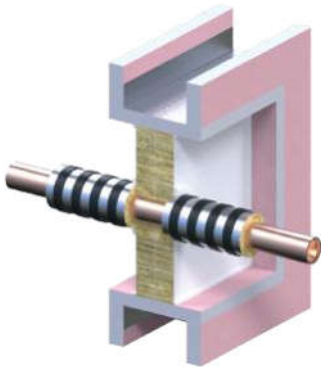

Promat

Australia

Promat Australia Pty Ltd

South Australia office

1 Scotland Road
SA 5031 Mile End South
☎ 1800 Promat (776 628)
☎ +61 8 8352 1014
✉ PAPL.mail@etexgroup.com

New South Wales office

Unit 1, 175 Briens Road
Northmead, NSW 2152
☎ 1800 Promat (776 628)
☎ +61 2 9630 0258
✉ PAPL.mail@etexgroup.com

Victoria office

Suite 205, 198 Harbour Esplanade
Docklands, VIC 3008
☎ 1800 Promat (776 628)
☎ 1800 334 598
✉ PAPL.mail@etexgroup.com

Queensland office

433 Logan Road
Stones Corner, QLD 4120
☎ 1800 011 376
☎ 1800 334 598
✉ PAPL.mail@etexgroup.com

www.promat.com

- The technical data provided in this publication is based on mean values prevalent at time of publication and is thus subject to fluctuation. It should not be regarded as a guarantee to system performance.
- All data contained herein conforms to and frequently surpasses generally accepted fire protection standards recognised by most professional fire science practitioners and regulatory authorities worldwide. The same general principle is equally applicable to all Promat products and systems. Promat has access to a considerable body of test authentication data and this can be provided on a complimentary basis upon request. It should be noted however that this publication replaces all previous editions in its entirety.
- This document is protected by International copyright laws. Reproduction and distribution in whole or in part without prior written permission is strictly prohibited. PROMAT, PROMASEAL, PROMASHEILD and logo are registered trademark of Etex NV or an affiliate thereof in Australia and/or other countries. Any use without authorisation is prohibited and may violate trademark laws.

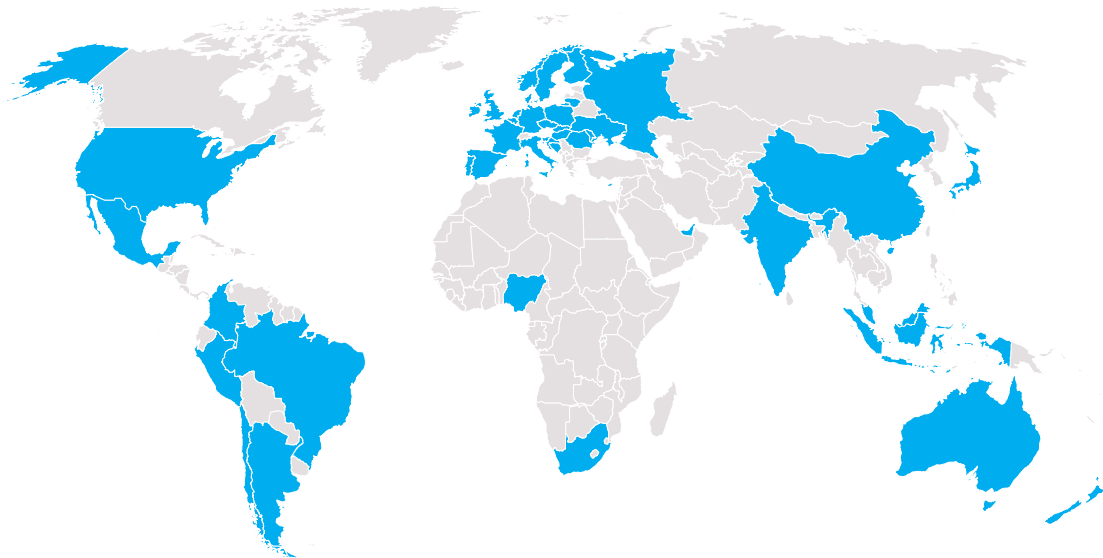

Etex is an international building materials specialist; the company wants to inspire people around the world to build living spaces that are ever more safe, sustainable, smart and beautiful. Founded since 1905 and headquartered in Brussels, Belgium, Etex currently operates in 101 production sites across 42 countries, employs more than 13,000 people and is one of the largest fibre cement producers in the world.

Through its subsidiaries, the group offers an extensive range of products: Plasterboard and passive fire protection systems, fibre cement solutions for cladding, façade and roofing as well as innovative modular systems.