

INNOVA
by etex

February 2026

DurabARRIER®

Pre-Cladding

Design and installation guide

Australia

DurabARRIER®

Backed by Etex, the global leader in fibre cement, Innova is bringing the change the industry needs. So now architects, builders, and homeowners can make the changes they want.

We'll never stop innovating our stylish fibre cement range. We'll never stop finding efficiencies and passing on the savings.

Change is what defines us and propels us forward. Change is the foundation we're built on.

Innova. Built on change.

Contents

1. Working Safely		4. Product Information		8. Construction Details	
1.1 Working Safely with Innova	3	4.1 Introduction	6	8.1 Layout	16
1.2 Working Safely Guidelines	3	4.2 Application	6	8.2 Residential Details	17
2. Handling and Storage		4.3 Product Conformance	6	8.3 Commercial Details	21
2.1 Storage	4	4.4 Quality	7	7. Installation	14
2.2 Handling	4	4.5 Fire Resistance	7	8. Construction Details	
2.3 Inspection	4	4.6 Energy Efficiency	7	8.1 Layout	16
3. Design and Construction		4.7 Weather Resistance	7	8.2 Residential Details	17
3.1 Considerations	5	4.8 Weather Protection	7	8.3 Commercial Details	21
3.2 General Framing	5	4.9 Structural Design	8		
3.3 Timber Framing	5	4.10 Compliance	9		
3.4 Steel Framing	5	4.11 Condensation Management	9		
3.5 Control Joints	5	4.12 Durability	9		
3.6 Thermal Break	5	4.13 Fasteners	9		
3.7 Flashings	5	4.14 Weatherproofing Tapes	10		
3.8 Alpine Regions	5	5. Products and Accessories			
3.9 Ground Clearances	5	5.1 Durabarrier®	11		
3.10 Termite Protection	5	5.2 Accessories by Others	11		
3.11 Moisture Management	6	6. System Overview	13		
3.12 Slabs and Footings	6				



Disclaimer

Innova products and systems designed by Etex Australia Pty Ltd are produced in accordance with the Building Code of Australia and relevant Australian Standards at the time of publication. Information in this document is to be used as a guide and is subject to project approval as many aspects of construction are not comprehensively covered. It is the responsibility of the designer to confirm Innova products and systems are suitable and meet the requirements for the intended application. Etex Australia Pty Ltd will not be held responsible for any claims resulting from installation not in accordance with the manufacturer's technical literature or relevant Standards.

Innova regularly updates technical literature; to ensure this document is current with the latest information, visit innovafibrement.com.au.

Warranty

DurabARRIER® is warranted for a period of 25 years.

Please refer innovafibrement.com.au for detailed warranty information.

About Innova

Innova is a commercial brand of Etex, a global building material manufacturer and pioneer in lightweight construction. Etex wants to inspire people around the world to build living spaces that are ever more safe, sustainable, smart, and beautiful. Founded in 1905 in Belgium, Etex are a family-owned company with more than 13,500 employees across 160 sites and 45 countries.

Innova are the fibre cement specialists, and distribute external cladding systems, interior lining and flooring substrate products specifically designed for the residential and commercial markets in Australia and New Zealand

With a deep understanding of the local market needs, the Innova range of fibre cement products provide architects, designers, builders and homeowners with a range of traditional and contemporary solutions to create spaces that work for their project.

Innova are constantly looking for ways to evolve and innovate their product offering, adapting to changes in the market.

Innova - built on change, backed by Etex.

1. Working Safely

1.1 Working Safely with Innova Fibre Cement

WARNING: P2 OR HIGHER-GRADE RESPIRATOR MUST BE WORN AND PRODUCT CUT OUTDOORS.

Innova fibre cement is manufactured from finely ground sand (silica), cellulose fibres, Portland cement and additives. In the product's manufactured state, it does not release airborne dust. Inhalation of Respirable Crystalline Silica (RCS) is hazardous and can cause damage to lungs, respiratory system, and cancer when users are exposed to dust over prolonged periods without adequate controls in place.

The risks associated with RCS inhalation arise during installation activities where mechanical methods are used for cutting, rebating, drilling, routing, crushing, sanding and cleaning up, disposing of, or relocating dust.

Before, during and after installation, it is important to be aware of activities that generate and lead to dust becoming airborne. Innova recommends following the Innova Working Safely Guidelines listed below in addition to site-specific safety procedures, Safe Work Australia guidelines and state or territory guidelines.









USERS ARE RESPONSIBLE FOR ADHERING TO GUIDELINES, RECOMMENDATIONS, SAFETY DATA SHEETS, INSTALLATION GUIDES, FEDERAL AND LOCAL REGULATIONS TO AVOID SERIOUS HEALTH IMPACTS.

Control the risks by utilising engineering controls (i.e. tools/equipment), administrative controls (i.e. workspace/safe work method statement) and correct PPE (i.e. respirator/eye wear).

1.2 Innova Working Safely Guidelines

Documentation

Read the current Safety Data Sheet and Working Safely documents available at innovafibreceement.com.au.

 <p>ALWAYS wear a properly fitted P2 or higher-grade respirator when cutting, drilling, rebating, sanding.</p>	 <p>ALWAYS use on-tool dust extraction when using power tools; M or H-Class vacuum fitted with a HEPA filter.</p>
 <p>ALWAYS alternate cutting activities with others to reduce exposure time.</p>	 <p>ALWAYS follow the tool manufacturer's guidelines for correct and safe operation.</p>
 <p>AVOID using power tools to cut or shape fibre cement products indoors.</p>	 <p>DO NOT dry sweep. Use wet suppression then sweep or H or M-Class vacuum.</p>
 <p>NEVER use a saw blade that is not designed to cut fibre cement.</p>	 <p>DO NOT continue activities if you are concerned about exposure levels or cannot comply with the above guidelines.</p>

Score and Snap Knife

Score the face of the product using a straight edge and repeat until adequate depth is achieved for a clean break when pulling upwards. Smooth rough edges with a rasp.

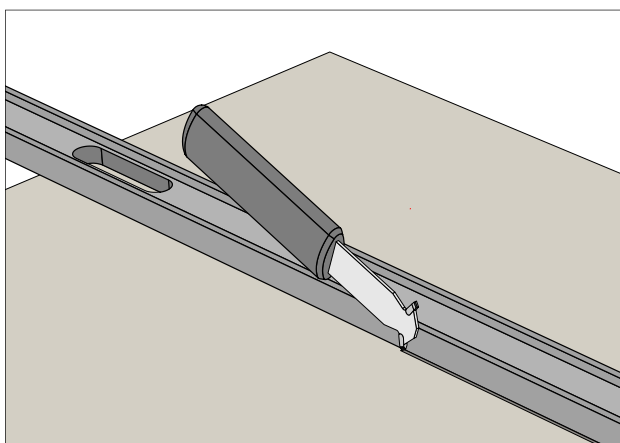

Power Saw

Circular, compound mitre and track saws with dust extraction provide accurate and clean cuts. Ensure saw is fitted with a PCD 4 or 6 tooth fibre cement blade. Always follow the manufacturers guidelines for safe operation.

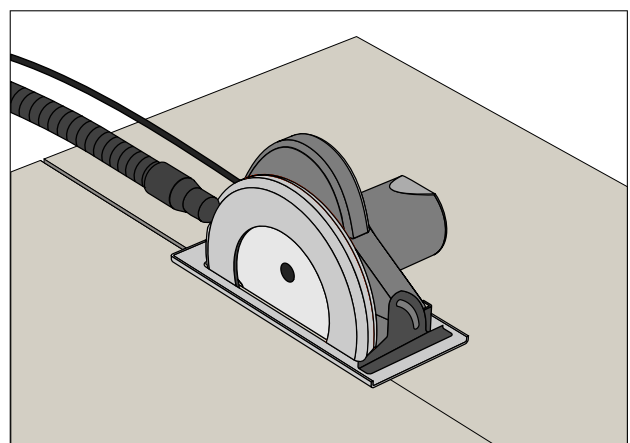

2. Storage and Handling

2.1 Storage

DurabARRIER® must be stored flat on pallets or level gluts at a maximum of 600mm, inside and undercover in dry conditions, protected from weather and potential influence of other trades.

If outdoor storage is unavoidable, extra care and attention is needed to protect the product from rain and direct sun.

Protect the packs with a solid color waterproof cover such as a tarpaulin. This cover must be pitched in the center to allow for moisture to run off and avoid water pooling.

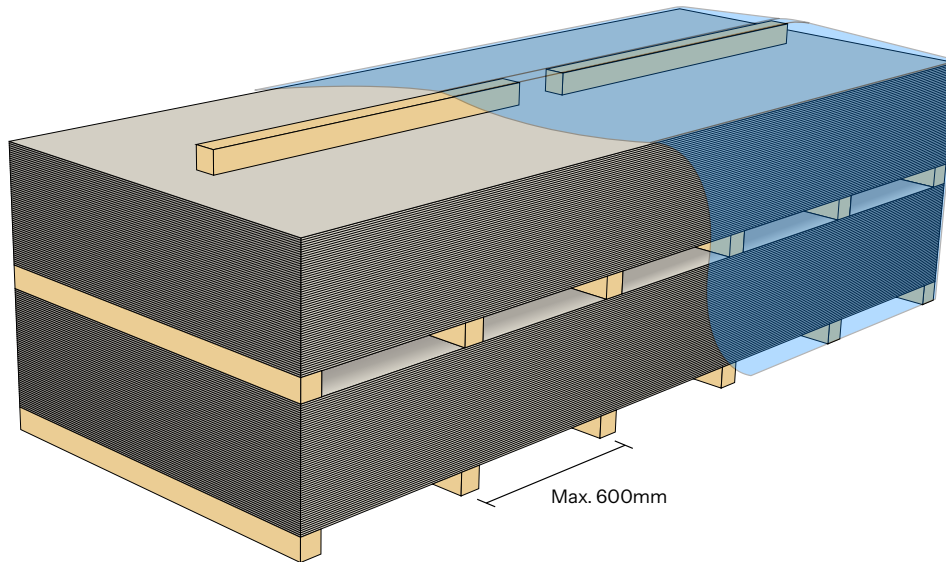

2.2 Handling

DurabARRIER® must be dry prior to fixing or finishing. Care should be taken to avoid damage to the ends, edges and surfaces. Panels must be carried on edge to avoid excessive bending. Coordination of installation is important to avoid damage from adjacent trades or activities. Damaged DurabARRIER® sheets must be replaced.

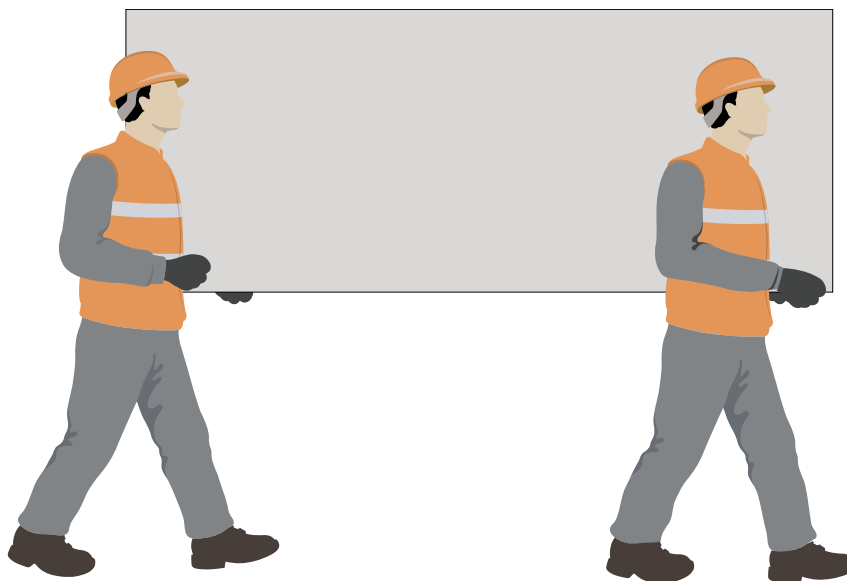

2.3 Inspection

Check sheets and components before starting installation. If there are signs of damage or defects, do not install and contact Innova for guidance.

3. Design and Construction

3.1 Considerations

It is recommended that for project specific facade designs be undertaken by a suitably qualified professional.

All aspects of design and construction must comply with the National Construction Code (NCC), state or territory specific regulations and Australian Standards (AS).

The construction details provided in this guide feature an express-joint cavity cladding system for reference purposes only. It is the responsibility of the designer to specify the cladding or facade system that meet the project requirements. The cladding will require regular maintenance as detailed by the cladding manufacturer.

Contact Innova for further information regarding use of DurabARRIER® with open jointed rain screen facade systems.

3.2 General Framing

All sheet edges must be fully supported by the primary frame. DurabARRIER® must be installed vertically over timber or light-gauge steel framing.

The deflection of the supporting structure should be limited span/250 for Serviceability Wind Load. DurabARRIER® is not to be used for bracing.

Frames must be straight and plumb within 3mm in any given 3000mm length of framing, DurabARRIER® will not straighten the primary frame.

3.3 Timber Framing

Use of a timber frame must be in accordance with AS 1684 – residential timber-framed construction or AS 1720.1 Timber structures, and the framing manufacturers' specifications.

Timber framing must be dry prior to installation. Fixing DurabARRIER® to framing with a moisture content exceeding 20% may result in issues caused by excessive timber shrinkage. The use of kiln-dried framing is strongly recommended.

3.4 Steel Framing

Use of a steel frame must be in accordance with NASH Standard Residential and Low-rise Steel Framing Part 1: Design Criteria; and the framing manufacturer's specifications.

Framing members must have a Base Metal Thickness (BMT) between 0.55 and 1.6mm. The steel framing must have the appropriate level of durability required to prevent corrosion.

DurabARRIER® must not be fixed directly to deflection head tracks. A minimum distance of 20mm is required from the top of the sheet to the slab or framing above.

3.5 Control Joints

Movement or control joints in the primary frame must be reflected through DurabARRIER®.

DurabARRIER® must not bridge over a control joint.

3.6 Thermal Break

NCC, Vol. 1 Section J3D6 and Vol. 2 Section 13.2.5 for both residential and commercial buildings require a minimum R0.2 thermal break be installed behind external cladding where the cladding and internal lining are fixed directly to the same steel frame. Thermal breaks are not required when using a cavity cladding system.

3.7 Flashings

NCC Vol.1 F3V1 and Vol.2 H2V1 requires the installation of flashings to building elements and critical junctions.

3.8 Alpine Regions

DurabARRIER® should not be used in situations where it will be in direct contact with snow or ice.

3.9 Ground Clearances

DurabARRIER® must not come into contact with standing water.

3.10 Termite Protection

NCC Vol. 2, Table 3.4.2 prescribes acceptable termite management systems and components for termite barriers. Where the exposed slab edge is used as part of the termite management system, a minimum of 75mm of the exposed slab edge must be visible to allow early detection of termite entry.

3.11 Moisture Management

Designers, specifiers and builders are responsible for managing moisture related risks through all phases of the construction project from design to completion.

The wall design and components must be appropriate for the intended application. The design must consider any unique project requirements, considering both the interior and exterior sides of the wall. Special consideration should be given to buildings that are in extreme climates, proximity to bodies of water or at risk of wind-driven rain.

In all areas, care should be taken in the design detailing, especially around all openings, corners and other junctions, to ensure weather resistance of the total system.

Prior to the installation of the cladding and the supporting substructure, particular care should be taken that to ensure necessary flashing and weatherproofing elements are complete.

To reduce the risk of moisture related issues, DurabARRIER® must be installed before windows, doors, meterboxes and pipe penetrations.

All other components and associated installation methods must be designed to manage moisture in walls and should comply with the relevant Australian Standards and the NCC.

3.12 Slabs and Footings

The building's foundation and slab must meet the standards outlined in AS 2870 Residential slabs and footings - Construction and the requirements of the NCC.

4. Product Information

4.1 Introduction

DurabARRIER® is a high performance 6mm fibre cement rigid air barrier for residential and commercial timber and steel framed construction. Comprised of fibre cement and coated with a hydrophobic sealer, DurabARRIER® is a durable and efficient weatherproofing solution. It is suited for all buildings requiring superior performance.

When used with a cladding system featuring a drained and ventilated cavity, DurabARRIER® facilitates effective moisture management by allowing the building envelope to breathe and reduces the risk of water ingress, ensuring a dry interior environment and preserving indoor air quality.

The material properties of DurabARRIER® deliver significant benefits to projects:

- Protection against moisture damage, corrosion and rot.
- Class 4 vapour permeable
- Sealed to rapidly displace moisture
- Capacity to withstand high wind pressures
- Provides weathertightness when paired with external cladding or facade systems.
- Allows internal construction activities to be carried out prior to cladding or facade installation.
- Provides six months of temporary protection of buildings ahead of cladding or facade installation.

Innova offers a comprehensive range of architectural products designed for compatibility with pressure equalised cladding or facade systems.

4.2 Application

DurabARRIER® is designed for:

- Superior performance.
- All building classes.
- All climates zones (Climate Zone 1 requires additional water barrier).
- Designed to withstand ultimate limit state (ULS) +/- 7kPa non-cyclonic and +/- 5.5kPa cyclonic.
- Highly corrosive environments.
- Non-combustible construction.

4.3 Product Conformance

DurabARRIER® is manufactured from Portland cement, finely ground sand, cellulose fibres and water. The sheets are cured in a high-pressure steam autoclave to create a durable, dimensionally stable product.

Innova fibre cement products are manufactured to conform to the requirements of AS/NZS 2908 Cellulose-Cement Products, Part 2: Flat Sheets.

DurabARRIER® is classified as Type A, Category 3.

4.4 Quality

DurabARRIER® is produced under ISO9001:2015 Certification for Quality Management Systems.

4.5 Fire Resistance

Non-Combustibility

DurabARRIER has been tested to AS 1530.1 Methods for fire tests on building materials, components and structures, Part 1: Combustibility and is deemed non-combustible.

DurabARRIER® is suitable for use where non-combustible materials are required in accordance with the National Construction Code (NCC), Vol 1 Clause C2D10 & Vol 2 Clause H3D2.

The project specifier or certifier is responsible for ensuring that the materials, accessories and components are suitable and compliant for the specific building.

Fire Hazard Properties

Innova fibre cement products have been tested in accordance with AS/NZS 1530.3 Methods for fire tests on building materials, components and structures, Part 3: Simultaneous determination of ignitability, flame propagation, heat release and smoke release.

The indices for Fire Hazard Properties are as follows:

- Ignitability Index: 0
- Spread of Flame Index: 0
- Heat Evolved Index: 0
- Smoke Developed Index: 0 – 1

Heat and Smoke Release

Innova fibre cement products have been tested in accordance with AS/NZS 3837 Method of test for heat and smoke release rates for materials and products using an oxygen consumption calorimeter and assessed against AS 5637.1 Determination of fire hazard properties, Part 1: Wall and ceiling linings as a Group 1 material.

Fire Resistance Level (FRL)

Where DurabARRIER® forms part of a fire rated wall system, the Siniat Multishield sheets must be installed directly to the primary frame prior to the installation of DurabARRIER®.

DurabARRIER® fastener length must be increased to accommodate the Siniat Multishield layer/s to maintain minimum embedment into the primary frame.

4.6 Energy Efficiency

Thermal Conductivity

At equilibrium moisture content, the approximate thermal conductivity of DurabARRIER® is 0.23W/mK.

Airtightness

The DurabARRIER® system can reduce leakage of internal air to outside the building envelope when installed as per the installation instructions.

A project's airtightness can be assessed during and after installation on a project using method 1 of AS/NZS ISO 9972 (NCC Vol. 1 J1V4). Depending on the results, adjustments can be made to allow for a high level of ventilation or sealing.

4.7 Weather Resistance

When incorporated into a facade system, DurabARRIER® serves as a robust alternative to traditional pliable building membranes, commonly known as wall underlay or wall wrap. Due to the rigid nature of DurabARRIER®, it is suitable as an alternative to NCC Vol. 1, F3D3.

Full-scale testing in accordance to AS/NZS 4284 Testing of Building Facades was conducted on a cavity-based, open, express-jointed cladding system incorporating DurabARRIER®. The system met F3P1 Weatherproofing requirements

DurabARRIER® rigid air barrier system weatherproofing result demonstrates the required performance in accordance with NCC F3P1 & H2P2 for applications where an external cavity wall:

- Has a risk score of 20 or less, when the sum of all risk factor scores are determined in accordance with NCC, Vol. 1 Table F3V1(a), Vol. 2 Table H2V1(a); and
- During construction is not subjected to a serviceability limit state (SLS) wind pressure of more than 2.5kPa; and
- Includes only windows and doors that comply with AS 2047.

Table 2: Weather Resistance Properties

Property	Result	Test Method
Vapour Control Classification	Class 4	AS/NZS 4200.1
Vapour Resistance (MNs/g)	0.0446	ASTM E96/E96M
Vapour Permeance (µg/Ns)	2.243	ASTM E96/E96M
Water Permeability	Pass	AS/NZS 2908.2
Water Barrier	Pass	AS/NZS 4201.4
Water Resistance	Pass	AS/NZS 4201.6

4.8 Weather Protection

DurabARRIER® may be utilised as temporary weather protection during construction, allowing for the commencement of internal lining installation once the following conditions are met:

- All sheet joints including penetrations and terminations must be sealed.
- The roof, soffit lining, windows, doors, and associated flashings must be installed to ensure the building is weathertight.
- Selected cladding must be installed within 6 months of DurabARRIER® installation.

4.9 Structural Design

In all cases, DurabARRIER® must be fixed directly to timber or steel framing members. For design wind pressures beyond the tables below, please contact Innova.

Table 3: Non-Cyclonic Wind Zones

Ultimate Design Wind Pressure ULS	Max. Stud Spacing	Max. Fastener Spacing	Timber Framing Fastener	Steel Framing Fastener
kPa	mm	mm		
1.5	600	200	2.8 x 40mm Flat head or fibre cement nail (min. class 3)	
2	600	175	or	
2.5	450	200	8ga x 40mm Wafer head or pan head screw (min. class 3)	
3	450	150		0.55BMT to 1.6BMT:
3.5	450	125		8ga x 25mm Wafer head or pan head screw (min. class 3)
4	400	125		
4.5	400	100		0.75BMT to 1.6BMT:
5	350	100	8ga x 40mm Wafer head or pan head screw (min. class 3)	10ga x 25mm Wafer head or pan head screw (min. class 3)
5.5	350	100		
6	300	100		
6.5	300	100		
7	300	100		

Table 4: Cyclonic Wind Zones

Ultimate Design Wind Pressure ULS	Max. Stud Spacing	Max. Fastener Spacing	Timber Framing Fastener	Steel Framing Fastener
kPa	mm	mm		
1.5	450	200	2.8 x 40mm Flat head or fibre cement nail (min. class 3)	
2	450	200	or	
2.5	450	150	8ga x 40mm Wafer head or pan head screw (min. class 3)	0.55BMT to 1.6BMT:
3	300	175		8ga x 25mm Wafer head or pan head screw (min. class 3)
3.5	300	150		
4	300	125		0.75BMT to 1.6BMT:
4.5	300	125	8ga x 40mm Wafer head or pan head screw (min. class 3)	10ga x 25mm Wafer head or pan head screw (min. class 3)
5	300	100		
5.5	300	100		

Table 5: DurabARRIER® Cantilever Limits

Ultimate Design Wind Pressure ULS	Max. Cantilever Distance
kPa	mm
Up to 3	150
3.5	135
4	125
4.5	120
5	115
5.5	110
6	105
6.5	100
7	95

Structural Design Notes

1. Ultimate Design Wind Pressures are determined in accordance with AS/NZS 1170.2 using a regional gust wind speed V_R determined on the basis that DurabARRIER® is a temporary structure that must be covered by the external facade within 6 months. (E.g. Average recurrence interval, ARI of 1:25)
2. This table remains applicable to designs based on regional gust wind speeds up to V_{500} and V_{1000} .
3. DurabARRIER® is to be fixed to the supporting structure in accordance with the installation instructions.
4. The external facade system shall be fixed through DurabARRIER® into structural framing by others.
5. In no case shall fixings be made to DurabARRIER® alone.
6. See Accessories By Others table for minimum fastener specification.
7. Where larger cantilever distances are required for your wind zone, contact Innova for further information.

4.10 Compliance

Durabarrier® meets the requirements as a rigid air barrier and complies with the National Construction Code (NCC) Vol.1 and Vol.2. Compliance documentation can be made available upon request.

Table 6: Compliance Standards and Performance

Property	Metric	Reference	BCA Requirement
Weatherproofing	Suitable for use as a weather barrier behind a cladding or facade system	AS/NZS 4284	Forms part of external wall system for compliance to F3P1 Weatherproofing
Water Control	Water Barrier	AS/NZS 4200.1 (AS/NZS 4201.4)	
Vapour Control	Vapour Permeability - Class 4 Suitable for Climate Zones 2 to 8	Water Control	
Non-Combustibility	Suitable for non-combustible construction	DTS via C2D10 (6)(c) via AS/NZS 2908.2	C1P2 Spread of Fire
Flammability Index	0, 0, 0, 1	AS/NZS 1530.3	
Thermal Conductivity	0.23W/mK	ASTM C518	J1P1 Energy Use
Thermal Expansion	CTE = 12×10^{-6}	Estimated Average	B1P1 Structural Reliability

4.11 Condensation Management

Durabarrier® has been tested in accordance with ASTM E96 and is classified as Class 4 vapour permeable in line with the water barrier standards outlined in AS/NZS 4200.1 Pliable building membranes and underlays, Part 1: Materials, and AS 4201.4 Resistance to water penetration.

Climate Zone 1: Apply vapour barrier membrane over the surface of Durabarrier® in accordance to AS 4200.

Climate Zones 2 to 8: No additional water barrier or wall wrap is required in Climate Zones 2 to 8 when installed correctly.

Visit the Australian Building Codes Board (ABCB) for further information on climate zones.

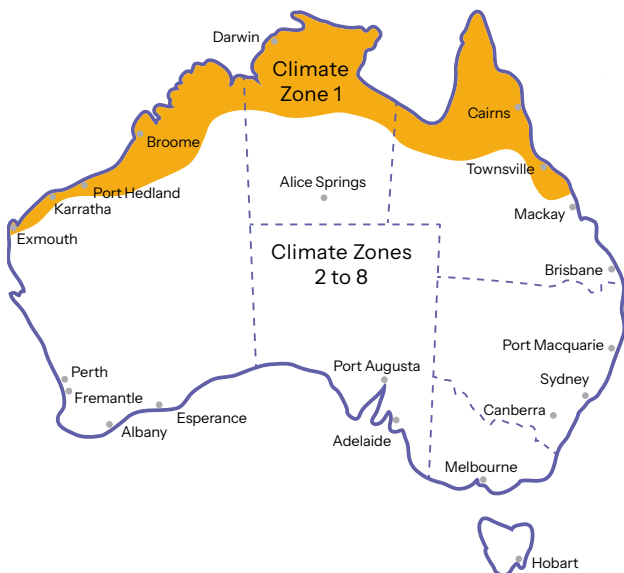

Figure 1 Climate Zone Map

4.12 Durability

Innova Fibre Cement products have proven their resistance to long-term decay caused by moisture exposure by successfully passing tests in line with AS/NZS 2908.2 Cellulose-cement products Part 2: Flat sheets:

- Water permeability (Clause 6.2)
- Heat rain (Clause 6.5)
- Warm water (Clause 6.4)
- Soak dry (Clause 6.6)

4.13 Fasteners

Fasteners must have the appropriate level of durability and be fully compatible with all other materials required for the intended project. Contact the fastener manufacturer for further information.

Fasteners must not be under or overdriven.

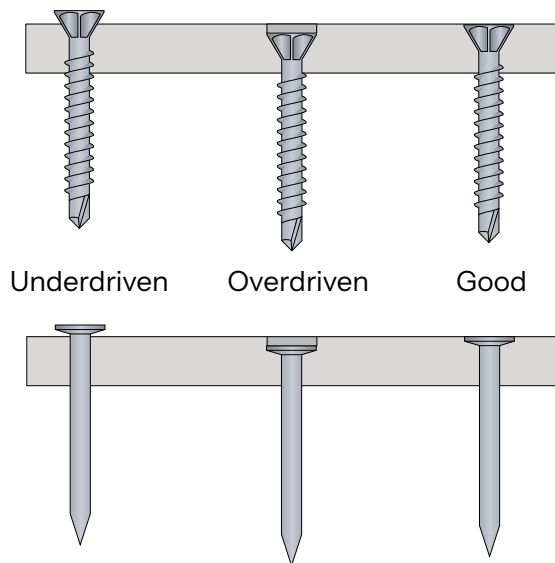

Figure 2 Fastener Positioning

4.14 Weatherproofing Tapes

General

Durabarrier® must be dry, clean, free of grease, dirt and debris prior to the application of the tape system.

If damage to Durabarrier® occurs, patching with flashing tape is permitted for damage up to 30x30mm in size.

Mechanical Flashings

All mechanical flashings must be taped back to the face of Durabarrier®

Openings

Class 1 & 10 buildings: Durabarrier® and associated taping system must be installed before window and door installation.

Class 2-9 buildings: Durabarrier® and associated taping system can be installed before or after window and door installation.

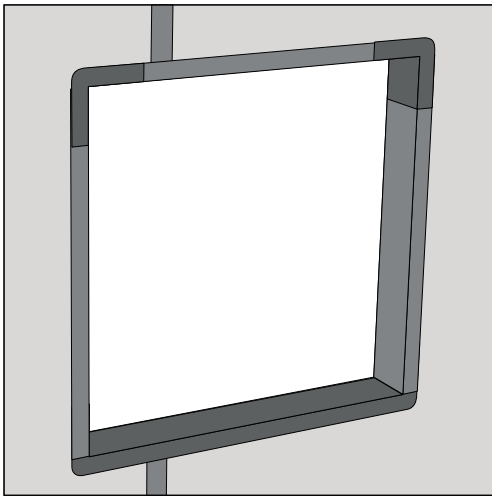

Application Tool

In all tape applications, a pressing tool is to be used to activate the pressure sensitive adhesive within the tape. No assurance of weathertightness or any other value expressed in the document can be assured if the tapes have not been applied as detailed.



Corners

Internal and external corners require the application of a single tape that is wide enough to cover both the sheet join and the supporting fasteners, this can generally be achieved using 100mm wide tape.



Porous Surfaces

To ensure maximum adhesion in applications on or around concrete and other porous surfaces, use an appropriate primer to aid adhesion.



Penetrations

Where possible, all penetrations should be in place prior to the installation of Durabarrier®. For pipes up to a maximum diameter of 320mm, use sealing grommets. For larger pipes or irregular shaped penetrations use flexible sill tape.



Junctions & Terminations

A 100mm tape can be used over typical building control joints or joins between dissimilar materials. For seismic movement joints, please contact Innova for additional information.

Exposure Limits

Pro Clima® weatherproofing tapes are suitable for up to 6 months exposure. Alternate tape systems may have a reduced exposure limitations.

Recommendation

Durabarrier® has been tested using Pro Clima® tapes.

Alternative tape systems may be used but remains the responsibility of the designer or facade engineer to determine suitability.







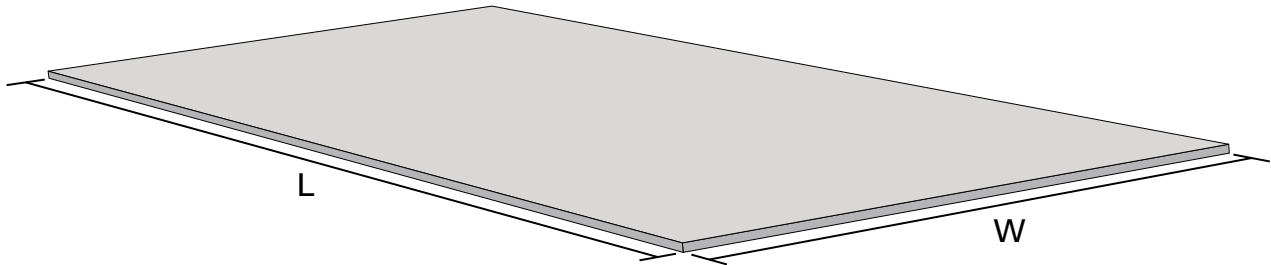

5. Products & Accessories

5.1 DurabARRIER® Information











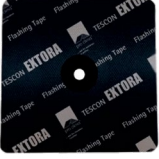

Product	Width (W)	Length (L)	Thickness	Coverage	Mass	Weight	Pack Size	Product Code
DurabARRIER® 6mm	1200mm	2450mm	6mm	2.94m ²	8.80kg/m ²	25.90kg	60	4092579
	1200mm	3000mm	6mm	3.60m ²	8.80kg/m ²	31.80kg	60	4092580

5.2 Accessories by Others

Product	Description	Size
Nails for Timber Frame		
	Fibre cement nail - Min. Class 3	2.8 x 40mm
	Flat head/clout nail - Min. Class 3	2.8 x 40mm
Screws for Timber Frame		
	Wafer head timber screw - Min. Class 3	8ga x 40mm
Screws for Steel Frame		
	Wafer head or pan head metal screw - Min. Class 3 <i>Suitable for 0.55 to 1.6mm BMT steel frames</i>	8ga-16 x 25mm
	Wafer head or pan head metal screw - Min. Class 3 <i>Suitable for 0.75 to 1.6mm BMT steel frames</i>	10ga-16 x 25mm
Sealant		
	Sealant Sika Sikaflex® PRO or PRO+ or similar	310ml 600ml
Weatherproofing Tapes		
	Pro Klima® TESCON® PRIMER RP or similar (liquid primer)	1L
	Pro Klima® PRESSFIX or similar (tool)	105 x 80mm

4.2 Accessories by Others (cont.)

Product	Description	Size
	Pro Clima® TESCONEXTORA® or similar (flashing tape)	30m Roll Width 60mm, 100mm, 150mm & 200mm
	Pro Clima® TESCONEXTOSEAL® or similar (flexible sill tape)	20m Roll Width 150mm & 200mm
	Pro Clima® ROFLEX or similar (pipe penetration sealing grommets)	Penetration Size Roflex 30: 30 to 50mm Roflex 50: 50 to 90mm Roflex 100: 100 to 120mm Roflex 150: 120 to 170mm Roflex 200: 170 to 220mm Roflex 250: 220 to 270mm Roflex 300: 270 to 320mm
Flashing		
	Corrosion-resistant Z-Flashing	Min. 75mm Upstand 6mm Depth Min. 30mm Downturn
Hand Operated Tools		
	Score and snap knife	
	Hand guillotine	
Power Tools		
	Fibre cement shears	
	4T or 6T PCD fibre cement blade	
	Plunge/track saw, circular saw fitted with dust extraction port	
	Class M or H vacuum	

6. System Overview

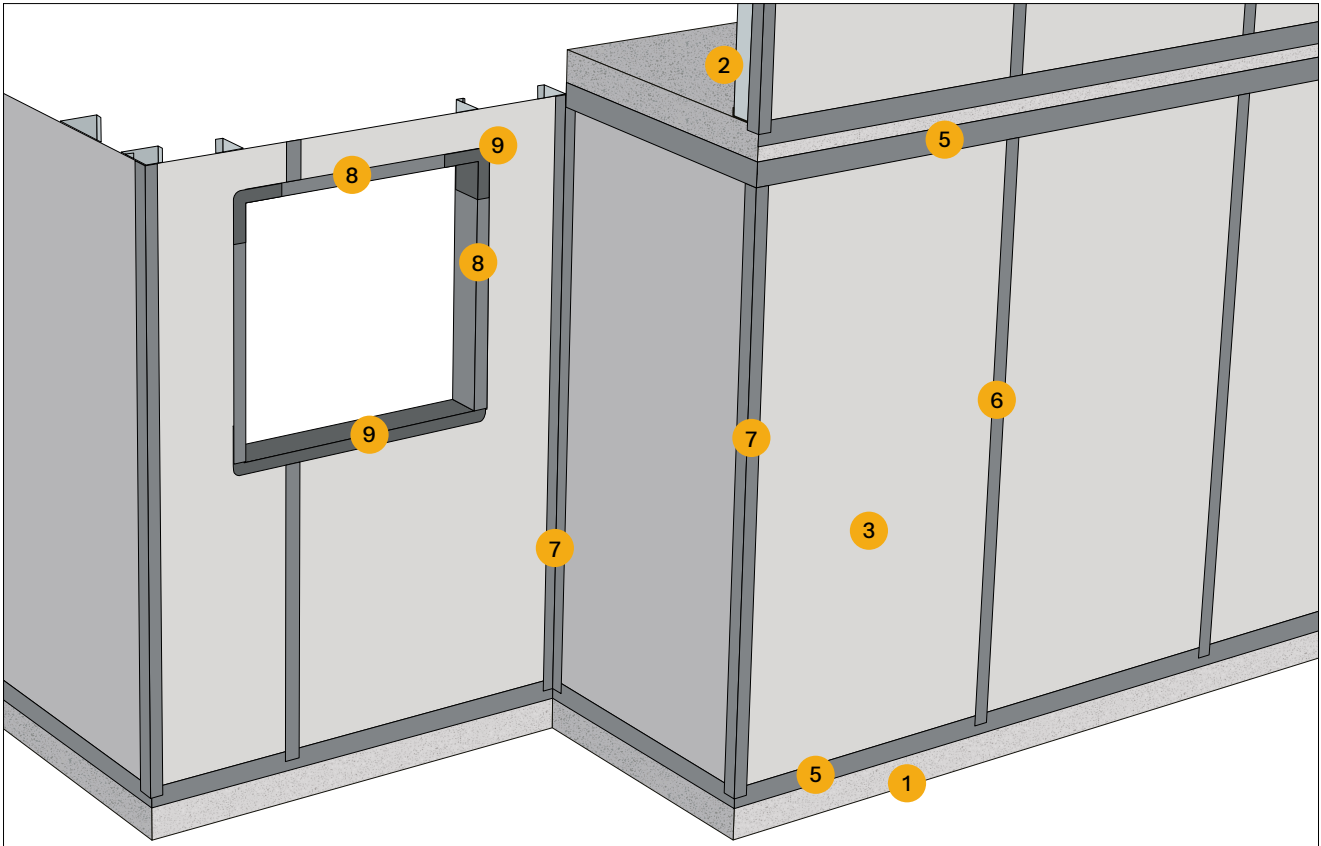

- | | | |
|--|------------------------------------|---|
| 1 Foundation (concrete, steel or timber) | 4 Sheet fasteners | 7 Corner tape: Min. 100mm wide |
| 2 Primary frame (timber or steel) | 5 Foundation tape: Min. 100mm wide | 8 Head and jamb tape: Min. 150mm wide |
| 3 DurabARRIER® | 6 Sheet join tape: Min. 60mm wide | 9 Head/jamb junction & sill tape: Min. 150mm wide |

7. Installation

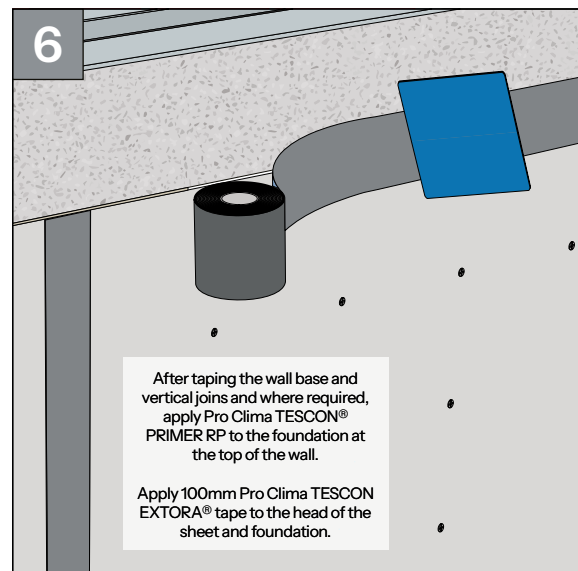
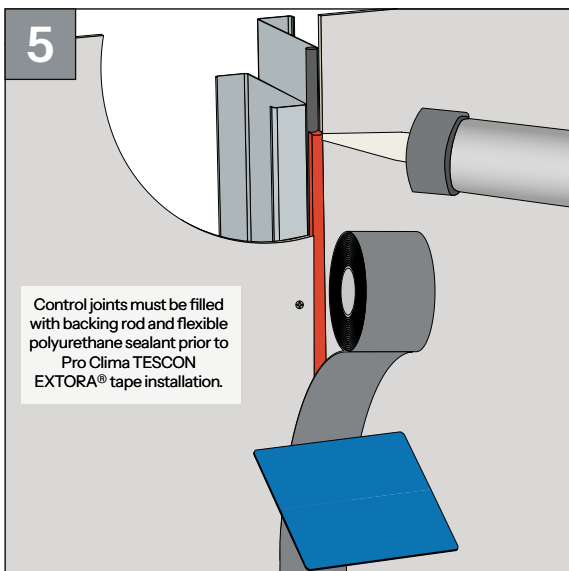
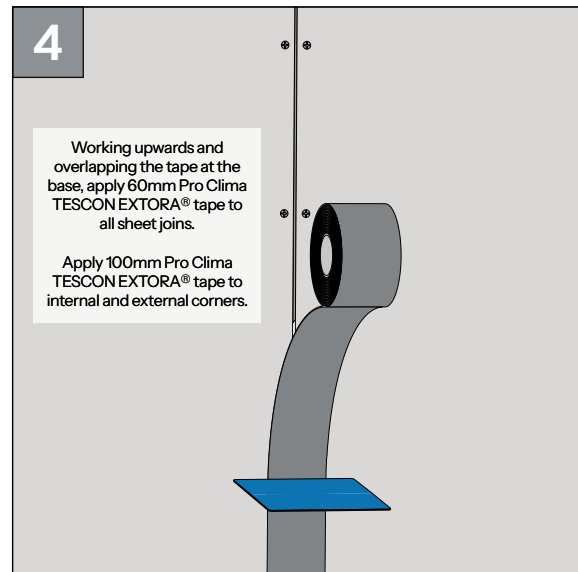
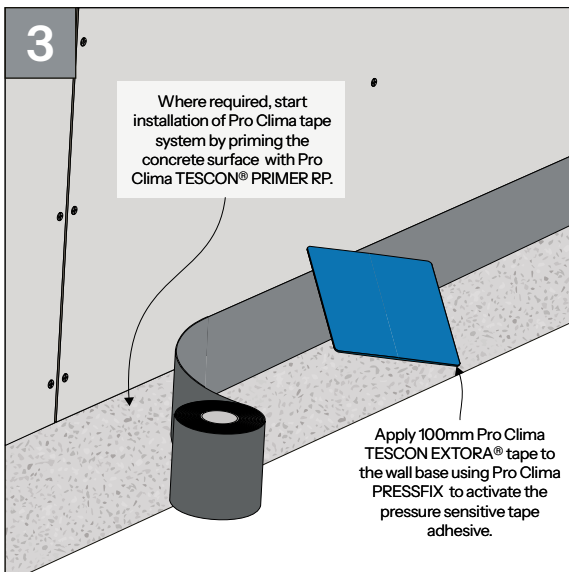
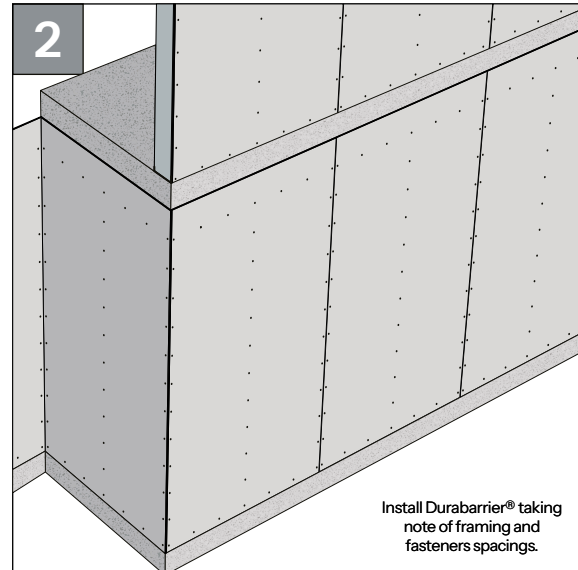
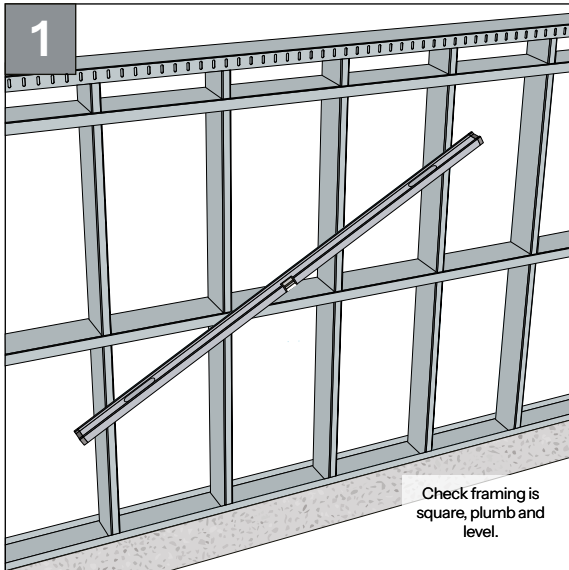

7. Installation

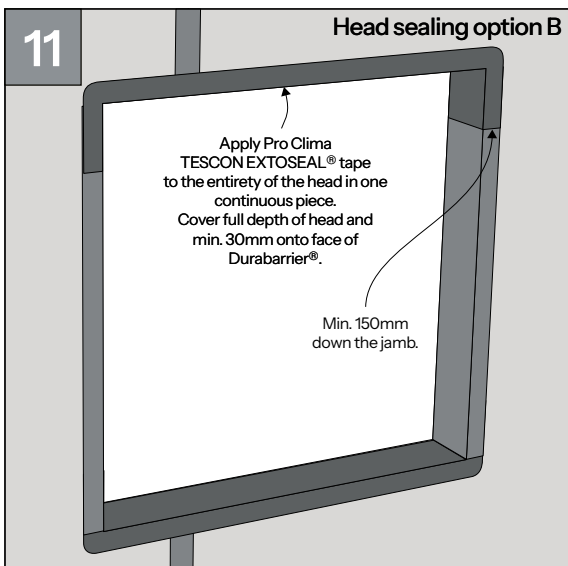
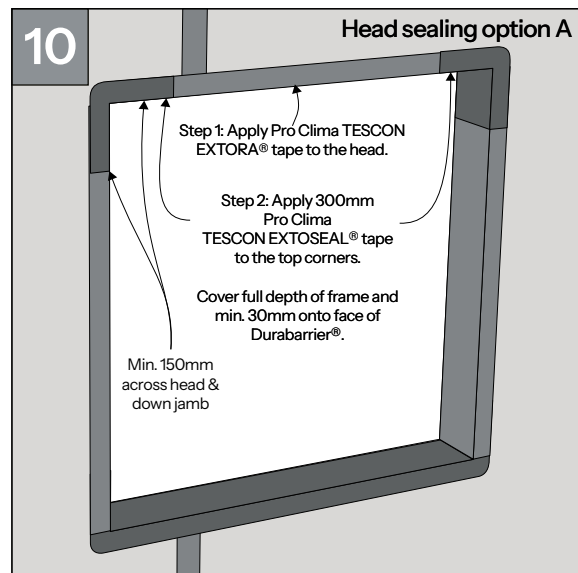
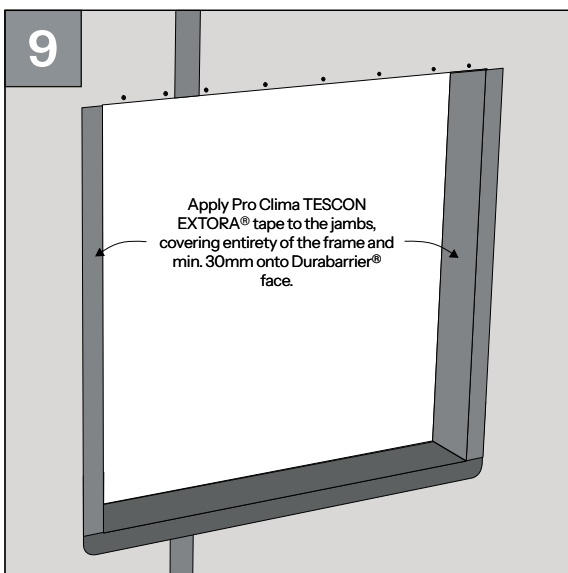
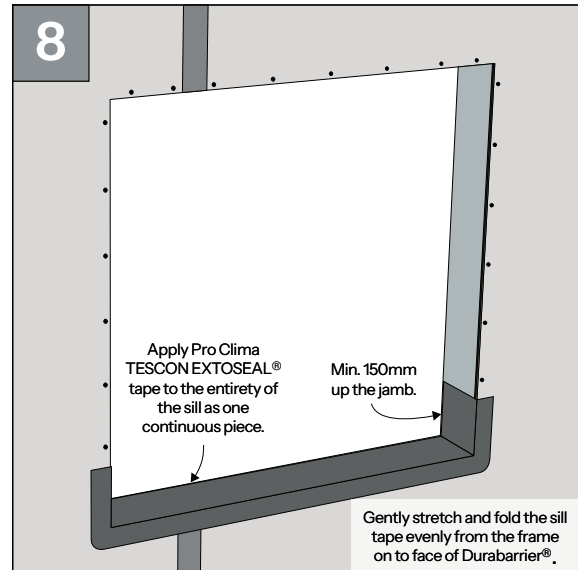
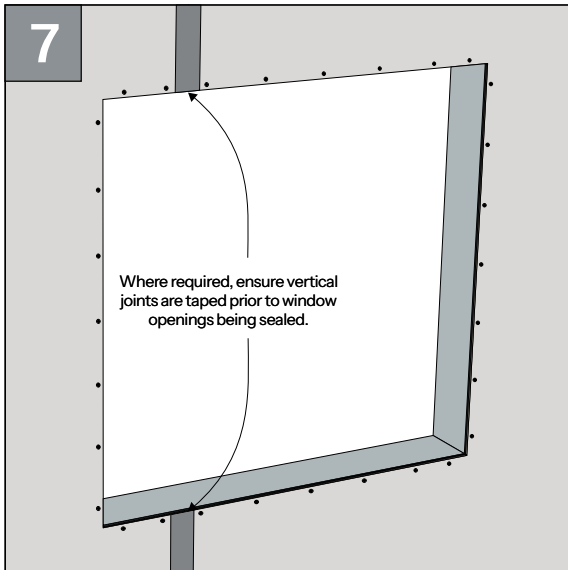

8. Construction Details

8.1 Layout

DurabARRIER® must be installed in a vertical orientation only. Plan the location of vertical and horizontal joints before installation begins to follow the framing design. Avoid joining DurabARRIER® panels inline with sides of openings.

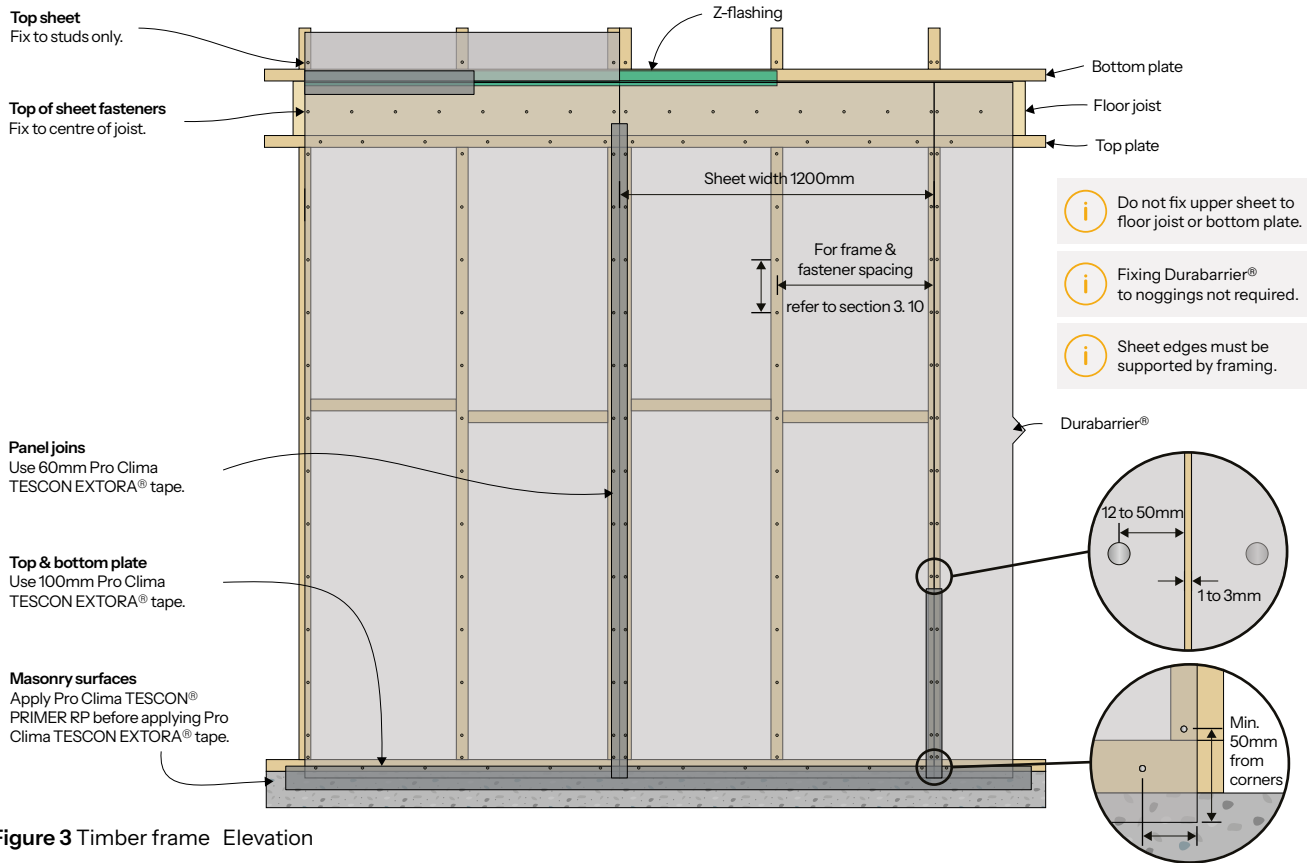

Figure 3 Timber frame Elevation

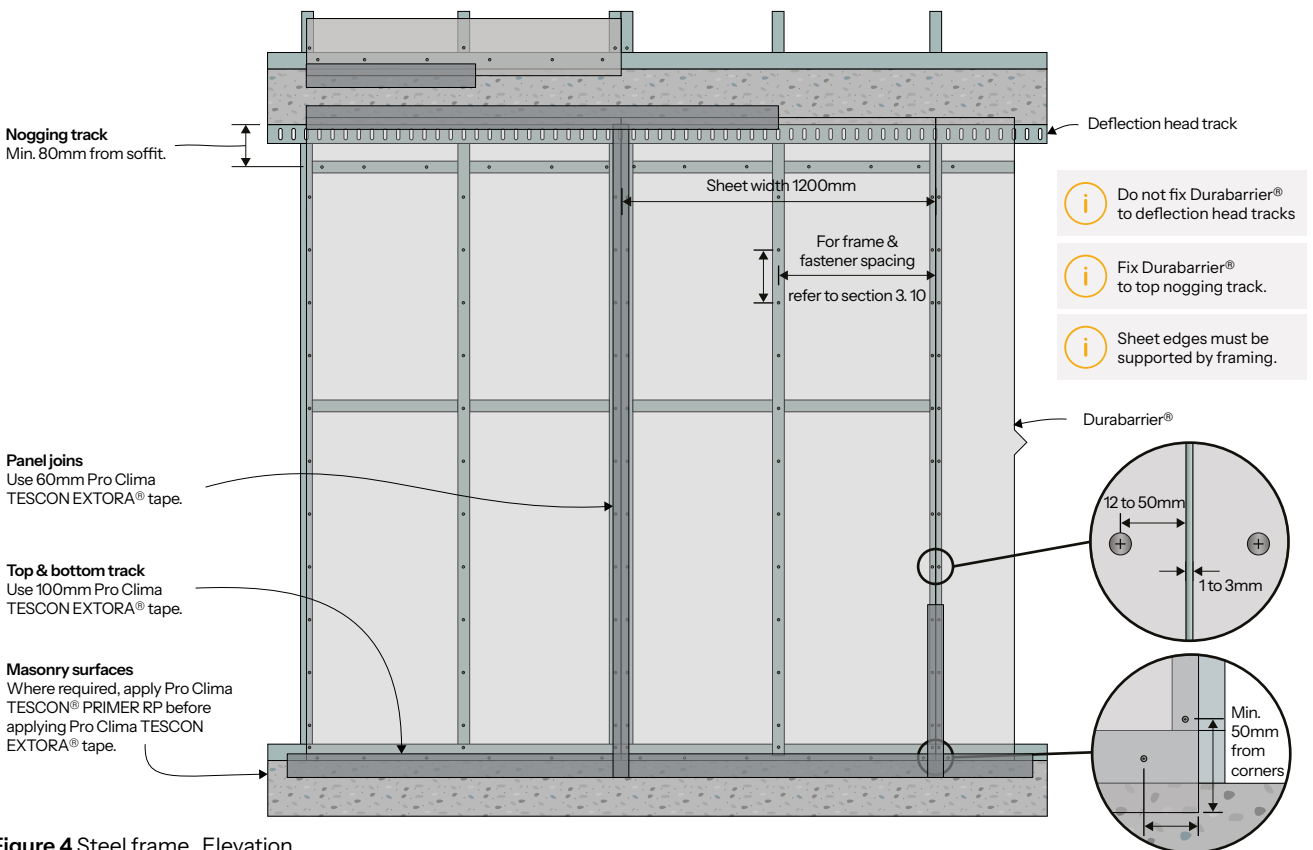

Figure 4 Steel frame Elevation

8. Construction Details

8.2 Residential Details

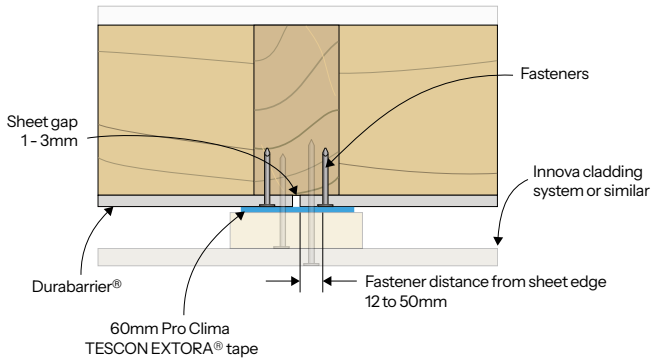

Figure 5 Vertical sheet joint detail Plan

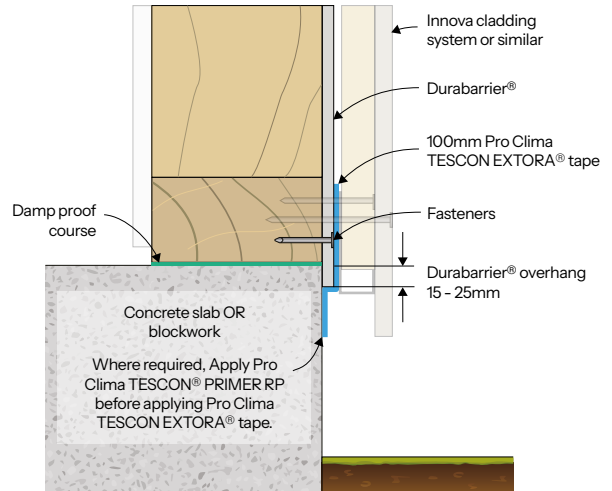

Figure 8 Bottom plate detail Section

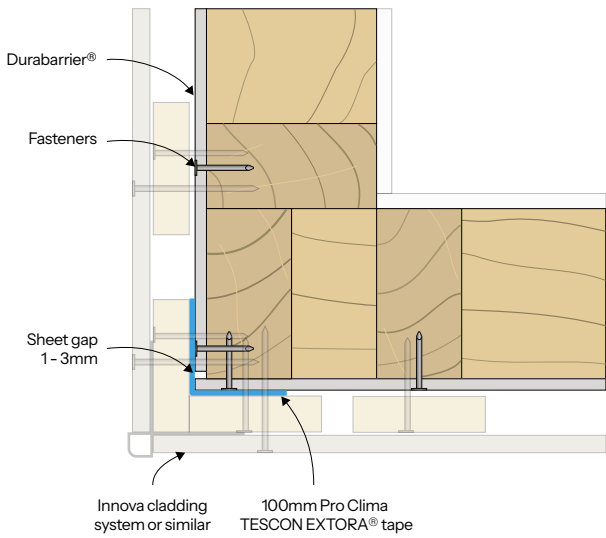

Figure 6 External corner detail Plan

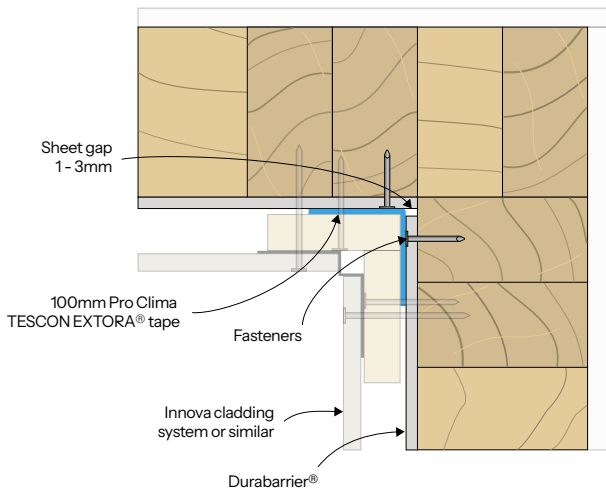
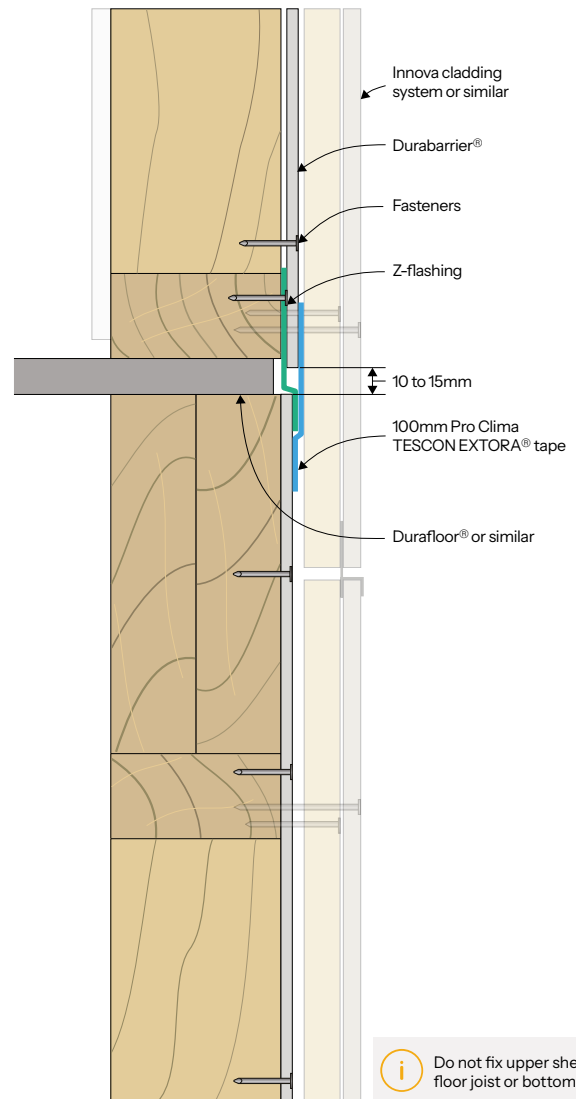

Figure 7 Internal corner detail Plan



i Do not fix upper sheet to floor joist or bottom plate.

Figure 9 Midfloor junction detail Section

8. Construction Details

8.2 Residential Details

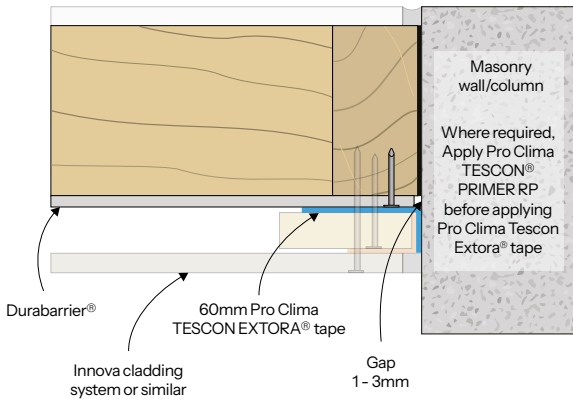

Figure 10 Wall/column abutment detail Plan

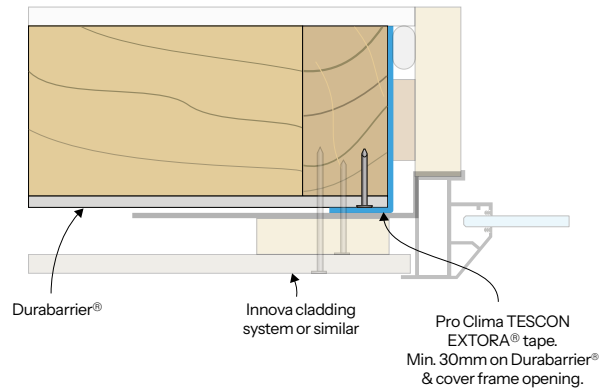

Figure 12 Window jamb detail Plan

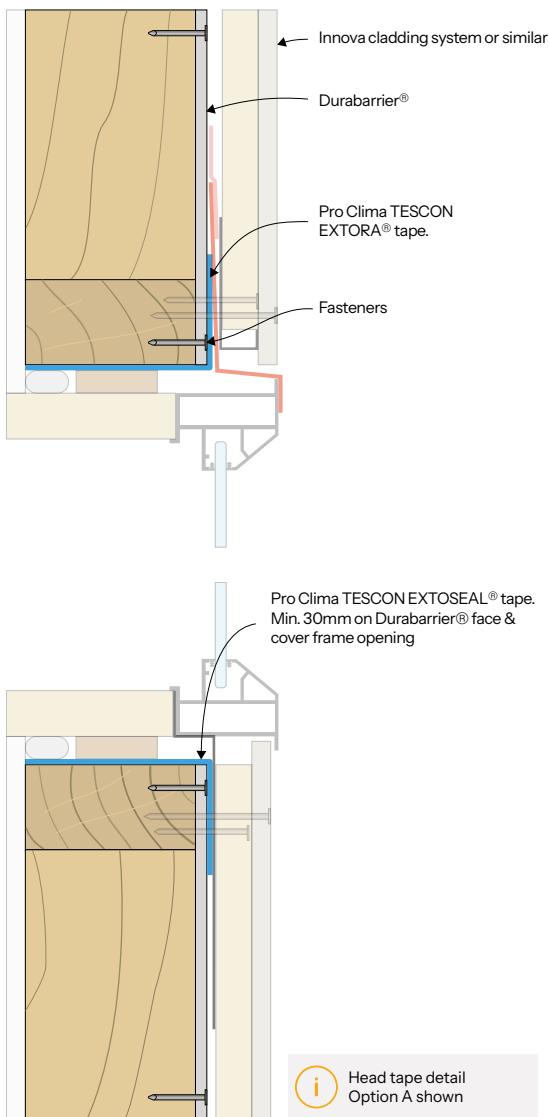

Figure 11 Window head & sill detail Section

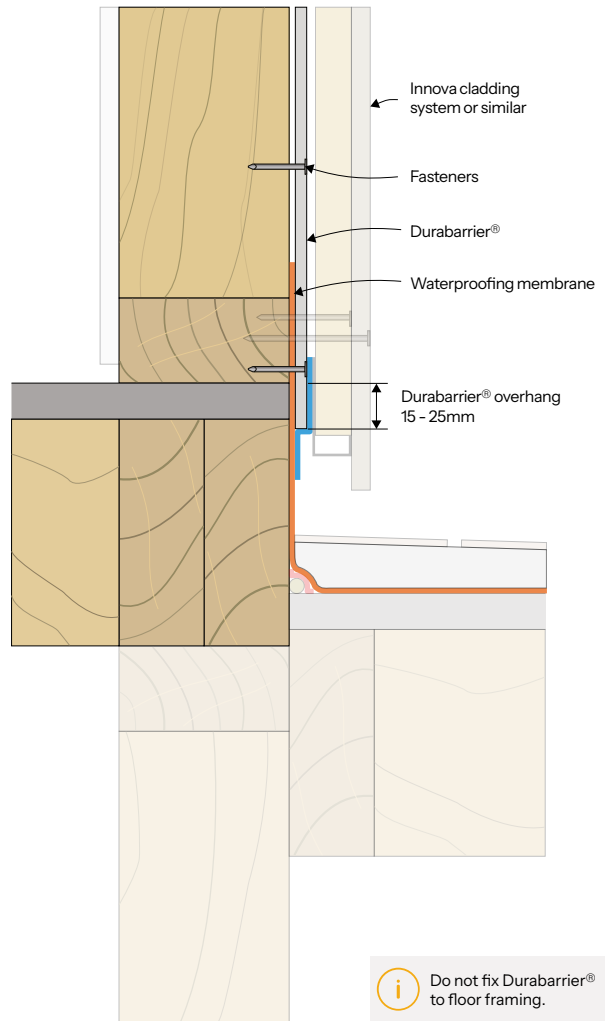

Figure 13 Enclosed balcony detail Section

8. Construction Details

8.2 Residential Details

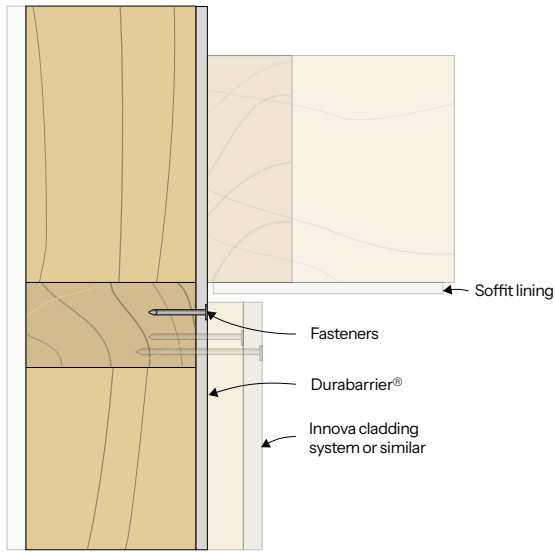

Figure 14 Soffit to external wall detail Section

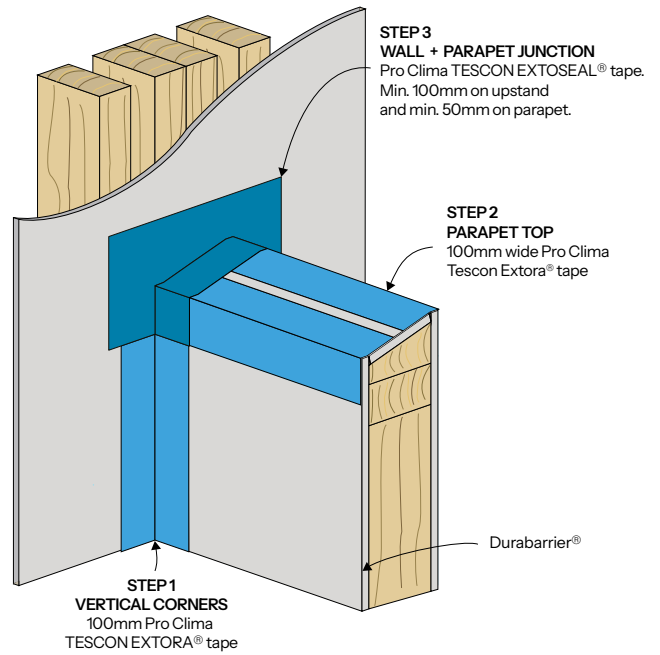

Figure 17 Parapet wall junction detail Isometric

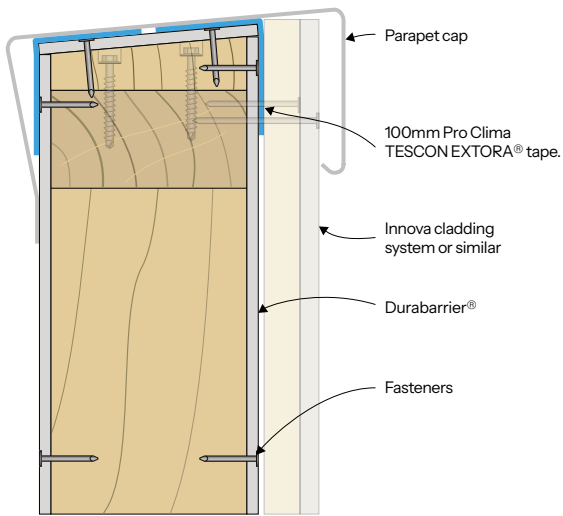

Figure 15 Parapet detail Section

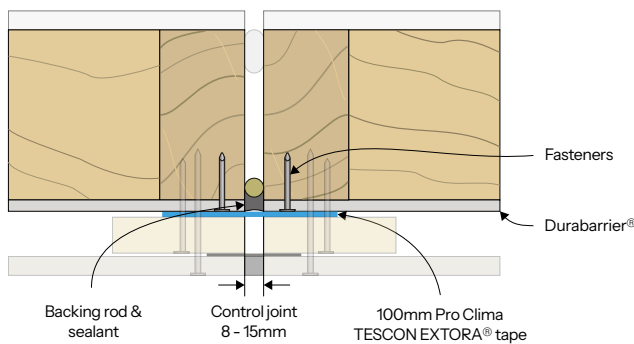

Figure 16 Vertical control joint detail Plan

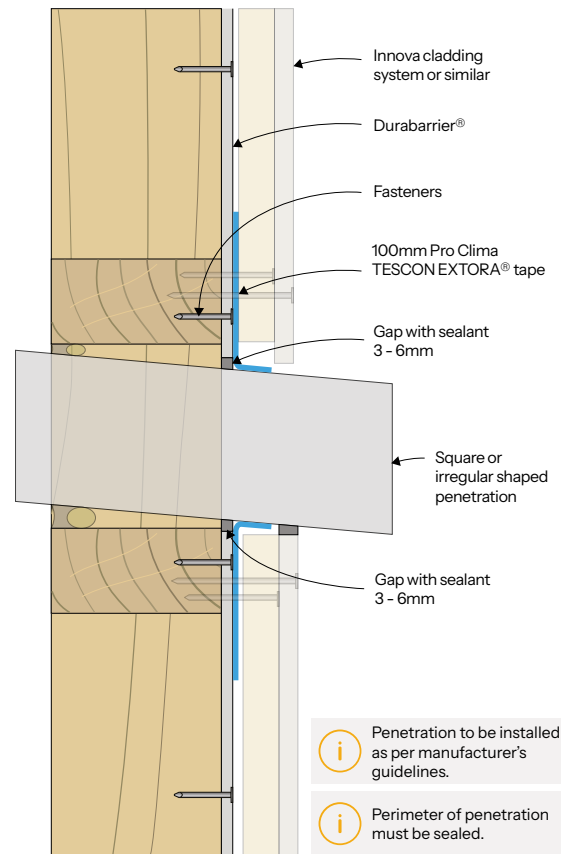

Figure 18 Square penetration detail Section

8. Construction Details

8.2 Residential Details

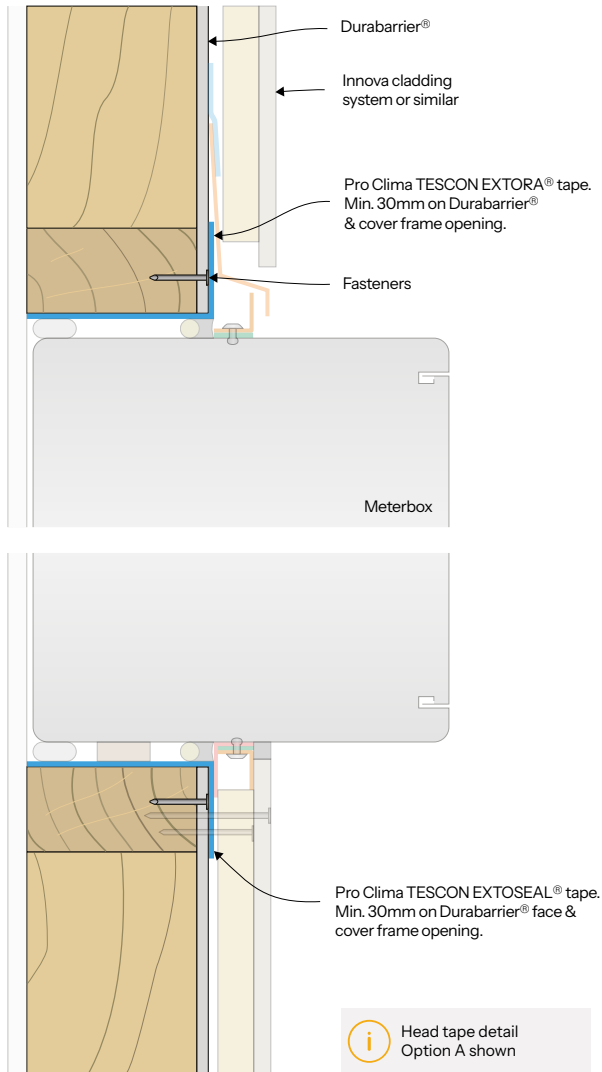

Figure 19 Meterbox head & sill detail Section

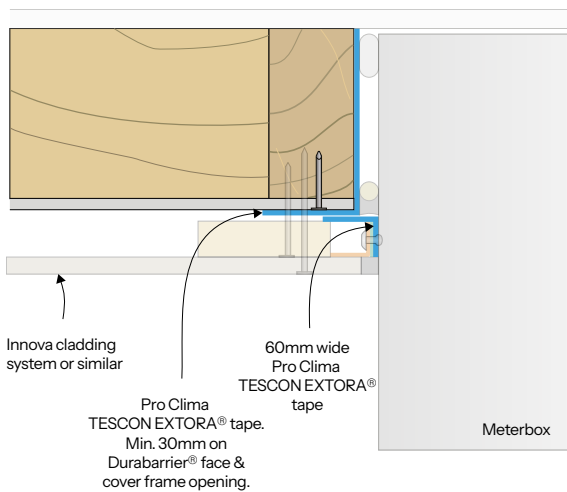

Figure 20 Meterbox jamb detail Plan

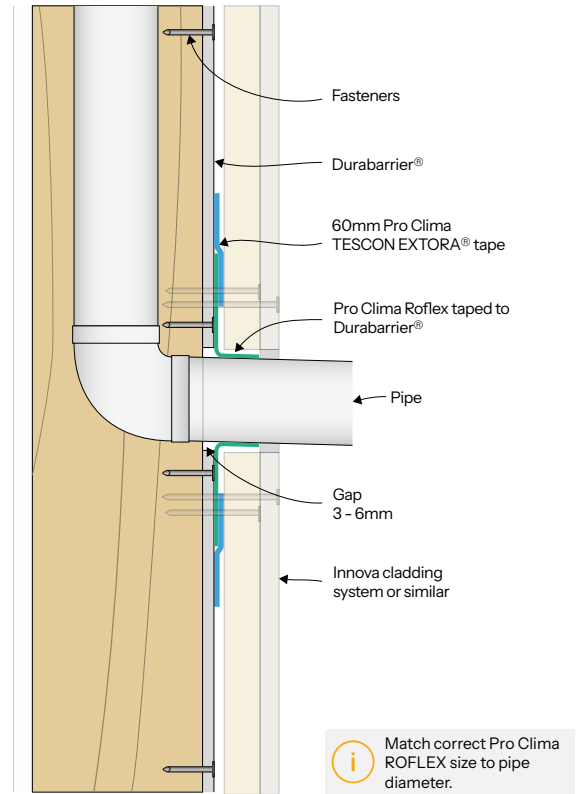

Figure 21 Pipe penetration detail Section

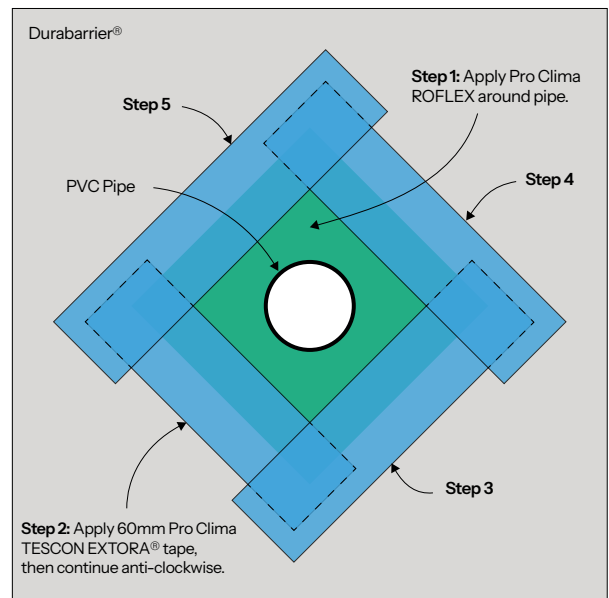

Figure 22 Pipe penetration detail Elevation

8. Construction Details

8.3 Commercial Details

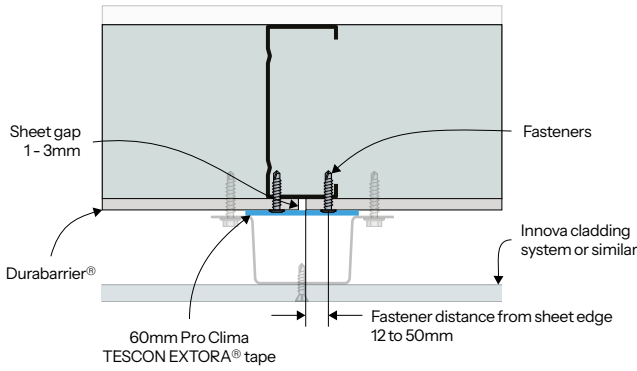

Figure 23 Vertical sheet joint detail Plan

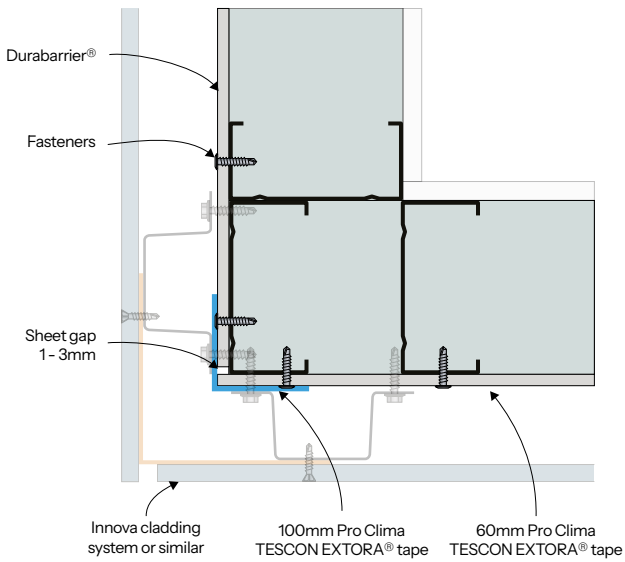

Figure 24 External corner detail Plan

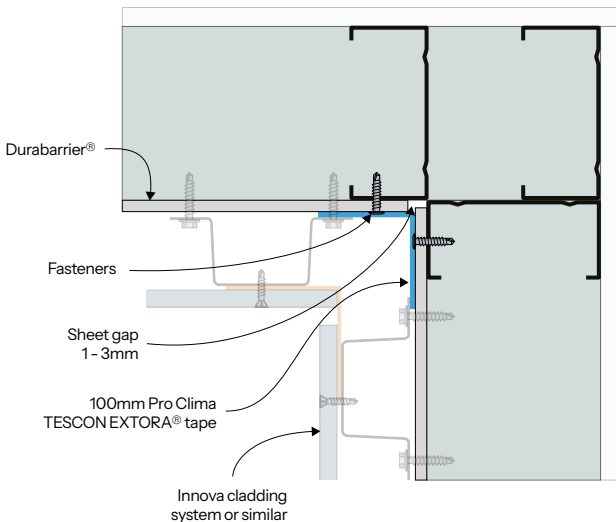

Figure 25 Internal corner detail Plan

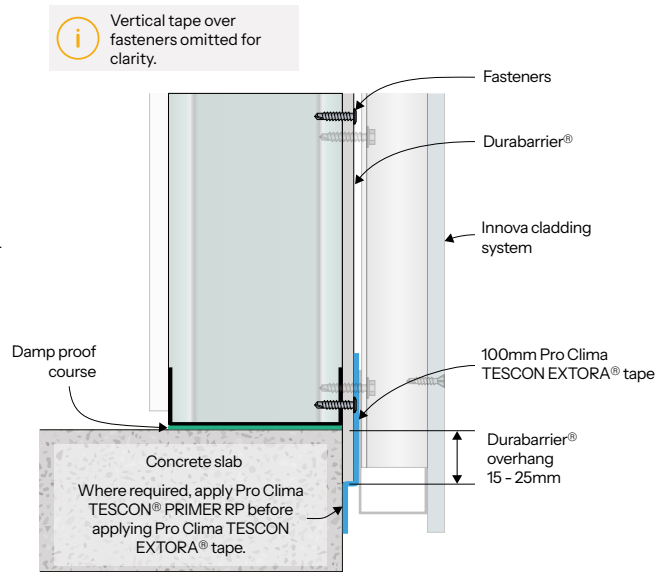

Figure 26 Bottom track detail - option A Section

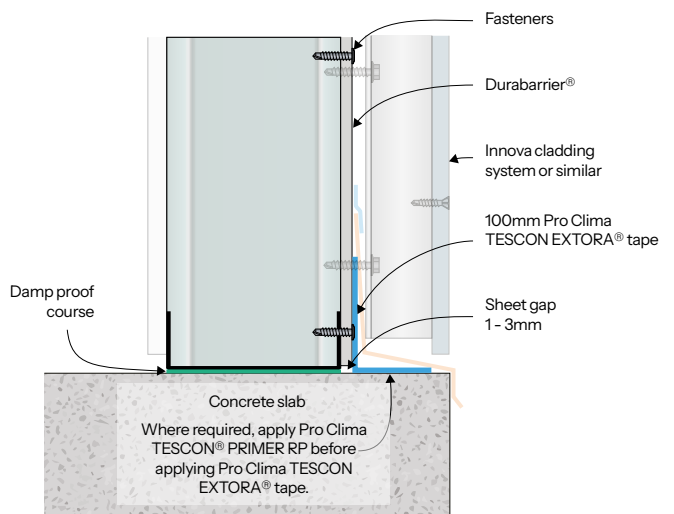

Figure 27 Bottom track detail - option B Section

8. Construction Details

8.3 Commercial Details

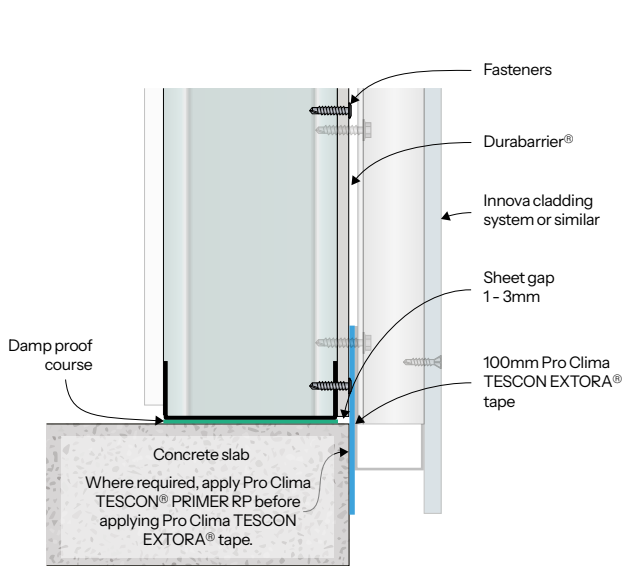

Figure 28 Bottom track detail - option C Section

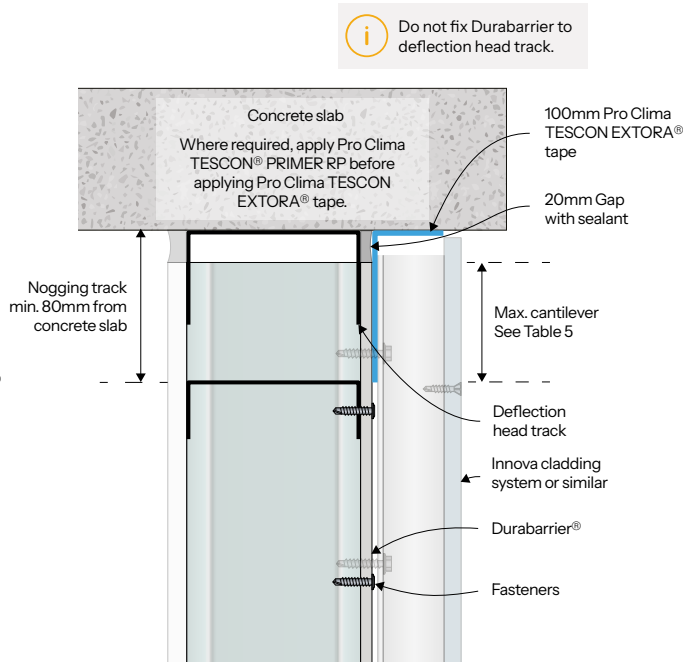

Figure 30 Deflection head detail - option A Section

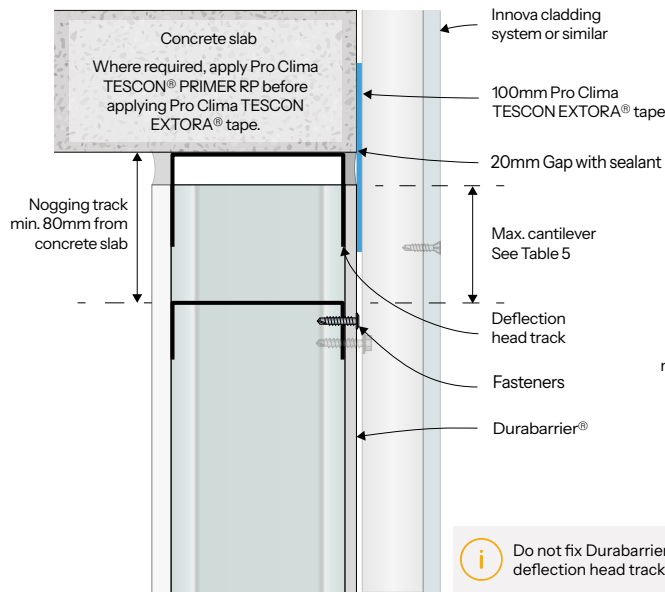

Figure 29 Deflection head detail - option B Section

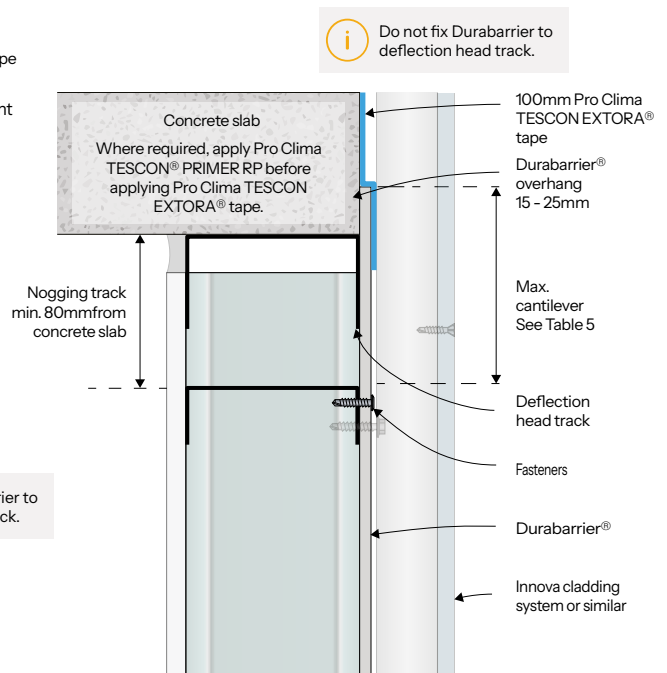

Figure 31 Deflection head detail - option C Section

8. Construction Details

8.3 Commercial Details

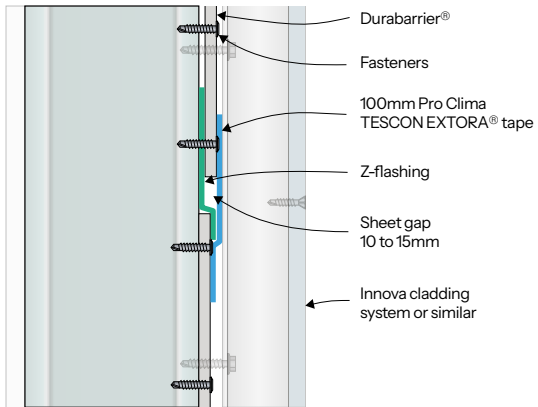

Figure 32 Horizontal sheet joint detail - Section

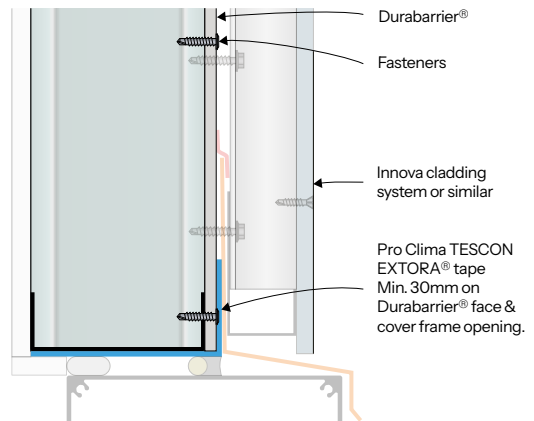

Figure 35 Window head & sill detail - Section

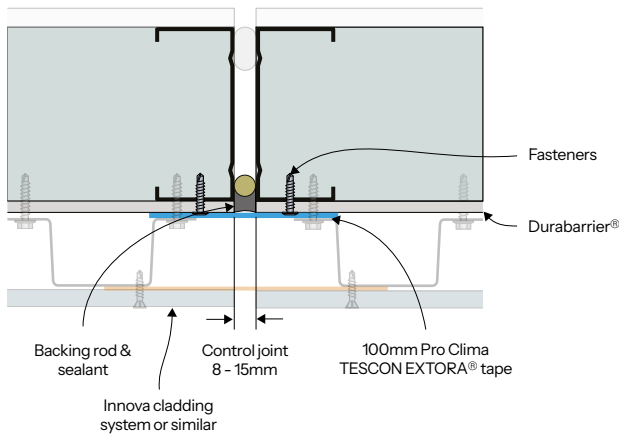

Figure 33 Vertical control joint - Plan

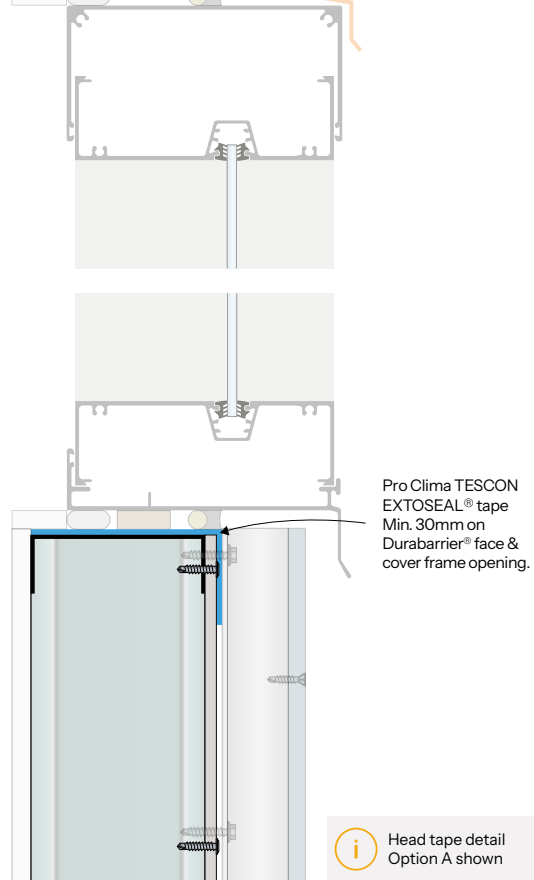
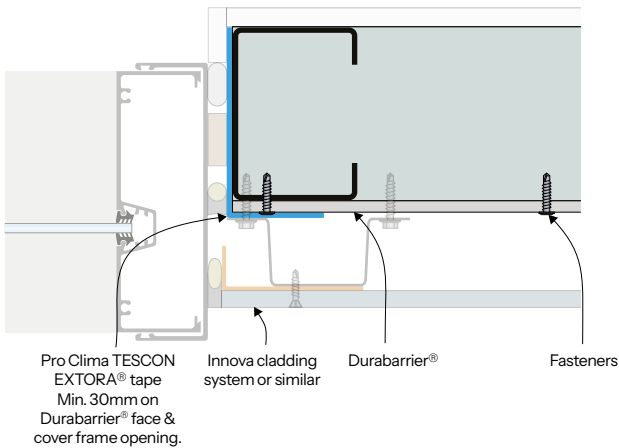

Figure 34 Window jamb detail - Plan



8. Construction Details

8.3 Commercial Details

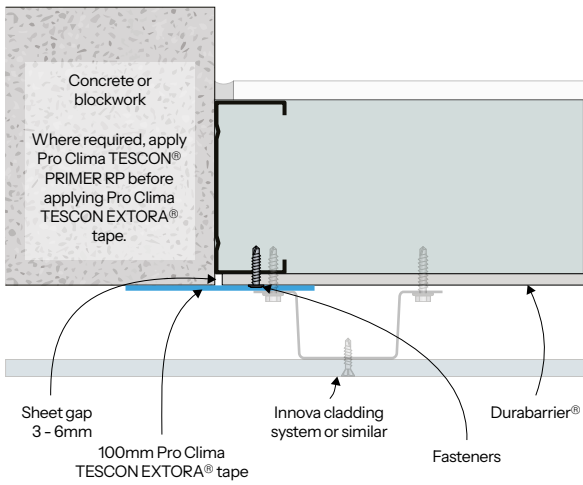

Figure 36 Wall/column abutment detail - option A Plan

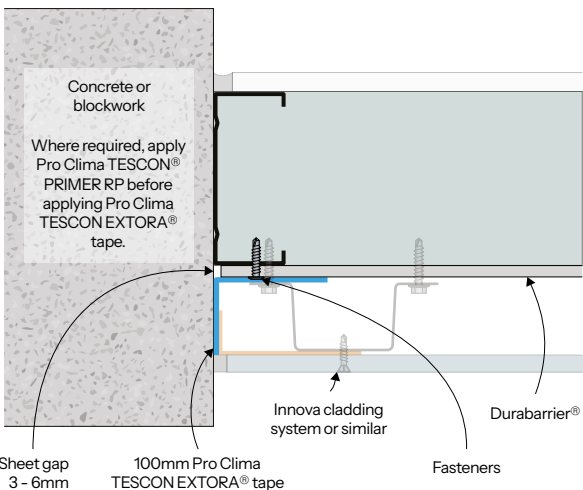

Figure 37 Wall/column abutment detail - option B Plan

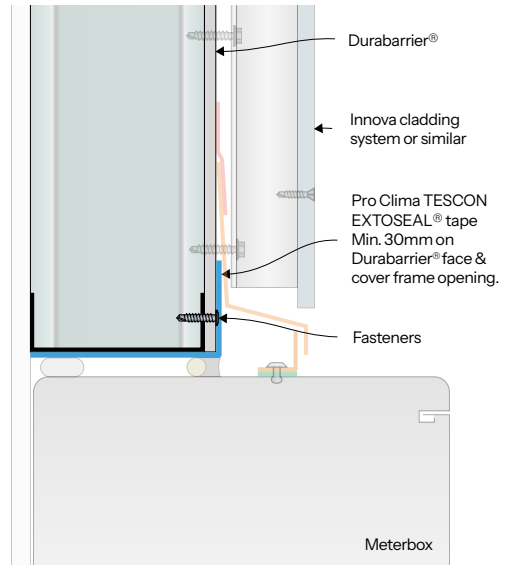

Figure 38 Meterbox head & sill detail Section

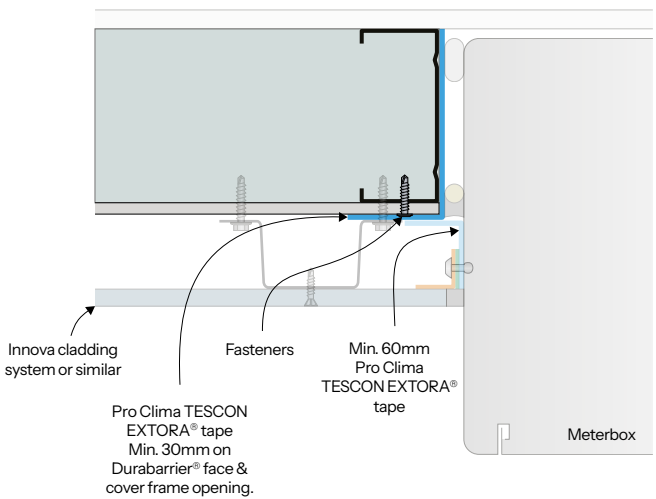
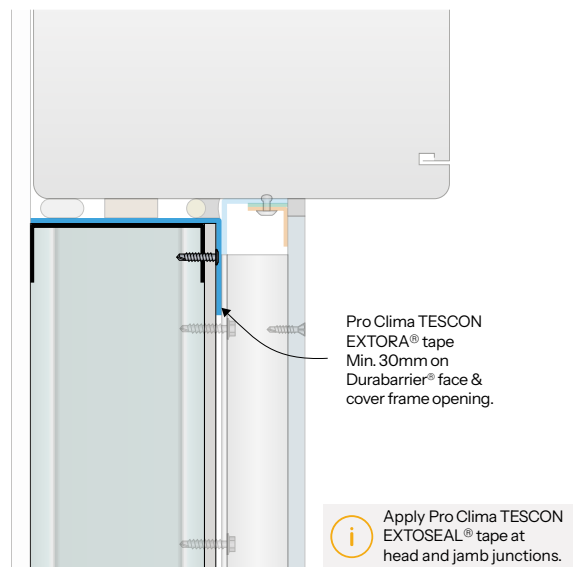

Figure 39 Meterbox jamb detail Plan

8. Construction Details

8.3 Commercial Details

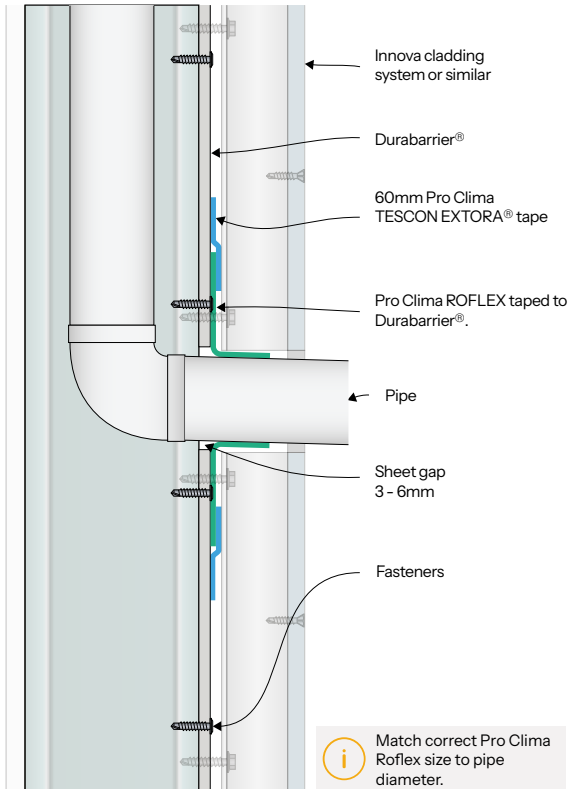

Figure 40 Pipe penetration detail Section

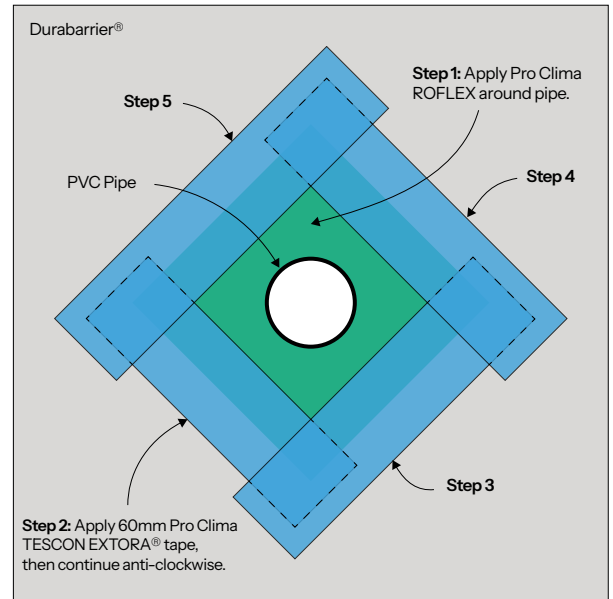

Figure 41 Pipe penetration detail Elevation

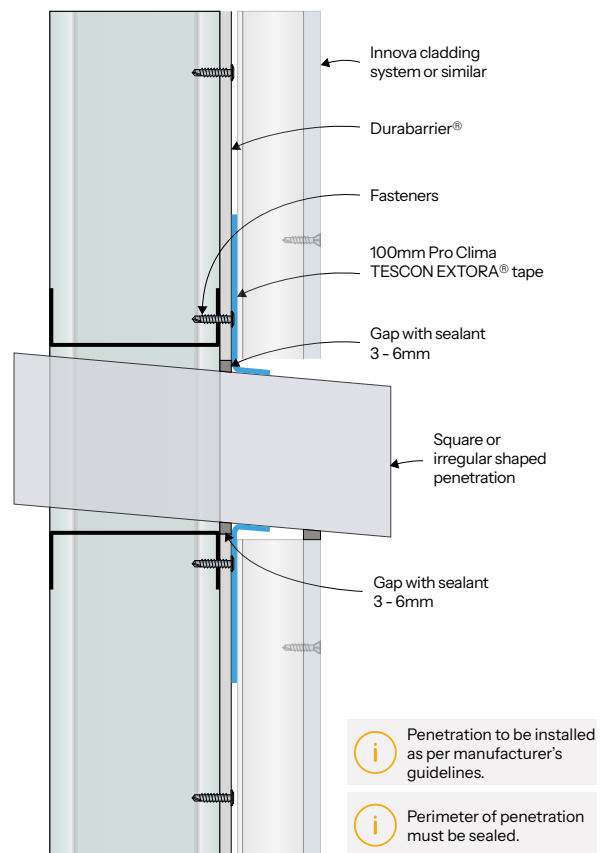

Figure 42 Square penetration detail Section

8. Construction Details

8.3 Commercial Details

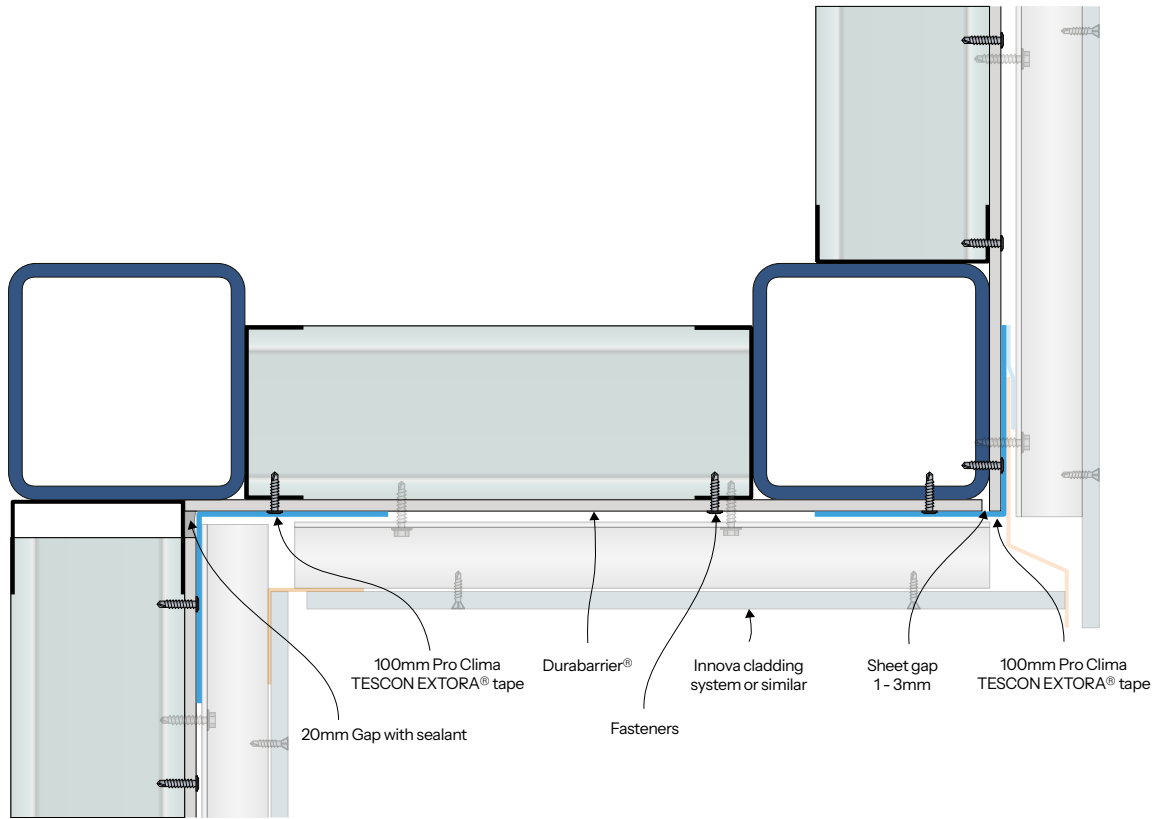

Figure 43 Cantilever wall soffit junction detail Section

Fibre cement specialists. Built on change.

Adelaide
08 8480 1700

Brisbane
07 3548 8400

Melbourne
03 9492 1700

Perth
08 9374 2900

Sydney
02 8107 9500

New Zealand
+64 9 273 1457

Technical
1300 652 242
innovatechnical@etexgroup.com

innovafibrement.com.au
[@innovafibrement](https://www.instagram.com/innovafibrement)



INNOVA
by etex

