

**Promat**

**EZ Path<sup>®</sup>**

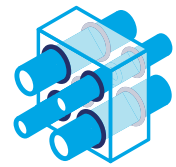

# INSTALLATION MANUAL

**Combined system EZ Path<sup>®</sup> & PROMASTOP<sup>®</sup>-CC**

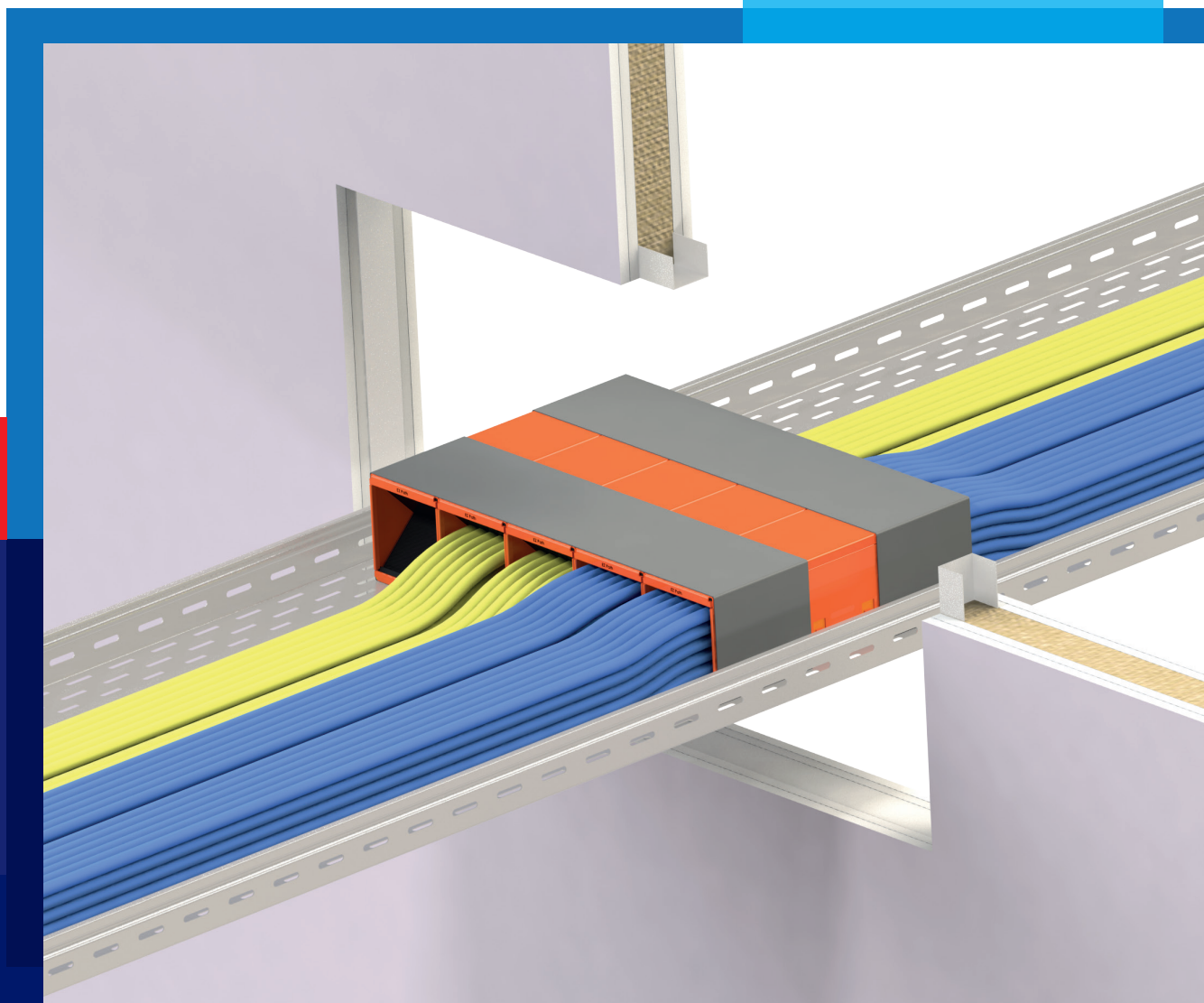

# PROMASTOP®-CC

## Product info & handling guide

PROMASTOP®-CC is a water-based 'hybrid' fire stopping coating. It combines the positive qualities of intumescent and ablative coatings. In the field of fire stopping penetrations, PROMASTOP®-CC provides reliable protection against the spread of smoke, fire and heat due to its foaming effect and simultaneous formation of a hard and solid char.

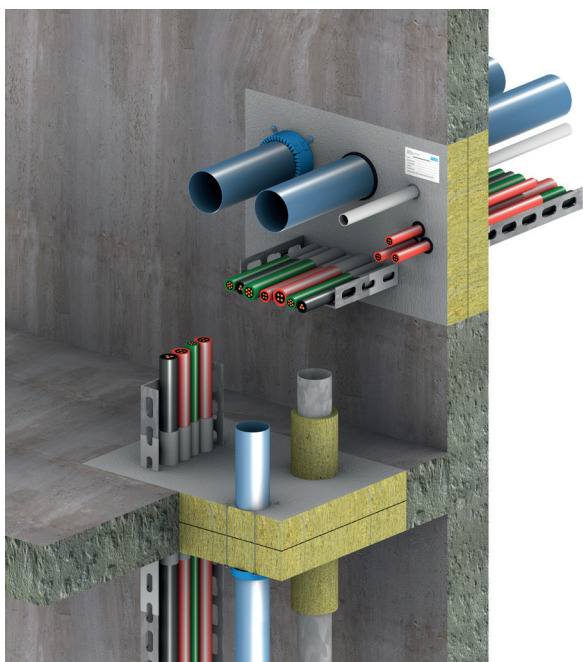

Mineral wool boards could be pre-coated as follows:

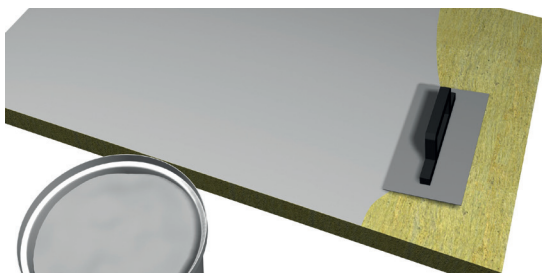

- ① Apply above mentioned wet film thickness (final dry film thickness  $\geq 0,7$  mm) and consider drying time; If mineral wool boards are not pre-coated, ensure during installation the final dry film thickness on surface of  $\geq 0,7$  mm.

### General information

- Storage and Transport temperature  $+3^{\circ}\text{C} - +35^{\circ}\text{C}$ .
- Substrate and ambient temperature  $+5^{\circ}\text{C} - +40^{\circ}\text{C}$ .
- Stir PROMASTOP®-CC well (we recommend a mechanical mixer).
- PROMASTOP®-CC can be diluted (maximum 0,5 litre clean water to each 12,5 kg bucket).
- PROMASTOP®-CC liquid can be applied with brush, roller, spatula or airless sprayed (nozzle 671, remove filters).
- Once opened containers should be fully used as soon as possible. Reseal containers properly after use.
- Drying time: approx. 8 hours at  $20^{\circ}\text{C}$  and a relative humidity of 65 % for 1 mm.
- Substrate must be free of oil, grease and dust.
- Use water to dampen and act as a primer for absorbent substrate.
- PROMASTOP®-CC is water based and might cause corrosion during its drying time on not-corrosion resistant metals. Therefore it is recommended to apply an adequate anticorrosive. Also to avoid corrosion on damaged spots on the metal due to ambient humidity and condensation, the anticorrosive is recommended.
- Ensure enough space around the services to install a fire stopping penetration seal, otherwise the necessary space has to be created.
- Clean tools with water after use.
- Overpainting is possible with paints based on dispersion, acrylic, polyurethane or polyurethane/acrylic mix. Adhesion and compatibility must be checked separately.

### Safety information

Safety data sheet available on request.

Coating on mineral wool			
Product	Dry film thickness	Wet film thickness	Consumption
PROMASTOP®-CC	0,7 mm	0,9 mm	1,35 kg/m <sup>2</sup>

Consumption per board	
1200 x 600 mm	0,97 kg/board

## Preparation of the opening and cable tray

Clean opening and cable tray. All the surfaces must be free of dust and loose material.



From one to five EZD 44T2 Pathways. The pathways can be attached to each others using the male female brackets on each side. The insulation bandage **T-Wrap 256** installed around EZ Path®. The width of the bandage is 127 mm on each side and is provided with a self adhesive.

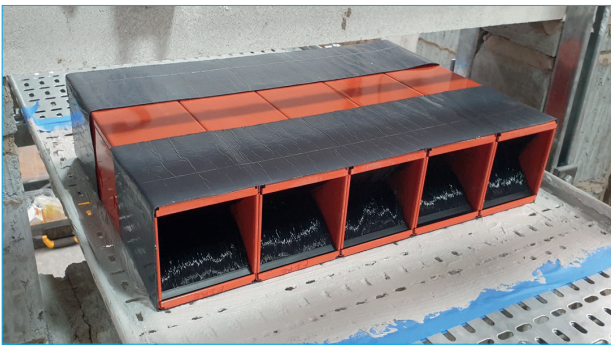

EZ Path® installed inside the cable tray and centered inside the wall.

EZ Path® can be attached to the cable tray by the mean of steel screws on the bottom side. The length of the screw to be max 10 mm.

1 mm thickness of **coating** applied on the cable tray on both sides and extending 200 mm from the surface of the wall.

50 mm thick PROMASTOP®-CC system to be installed flush with both surfaces of the wall.



The coating and the pre-coated boards to be installed in accordance with all relevant guides and specifications of the manufacturer.

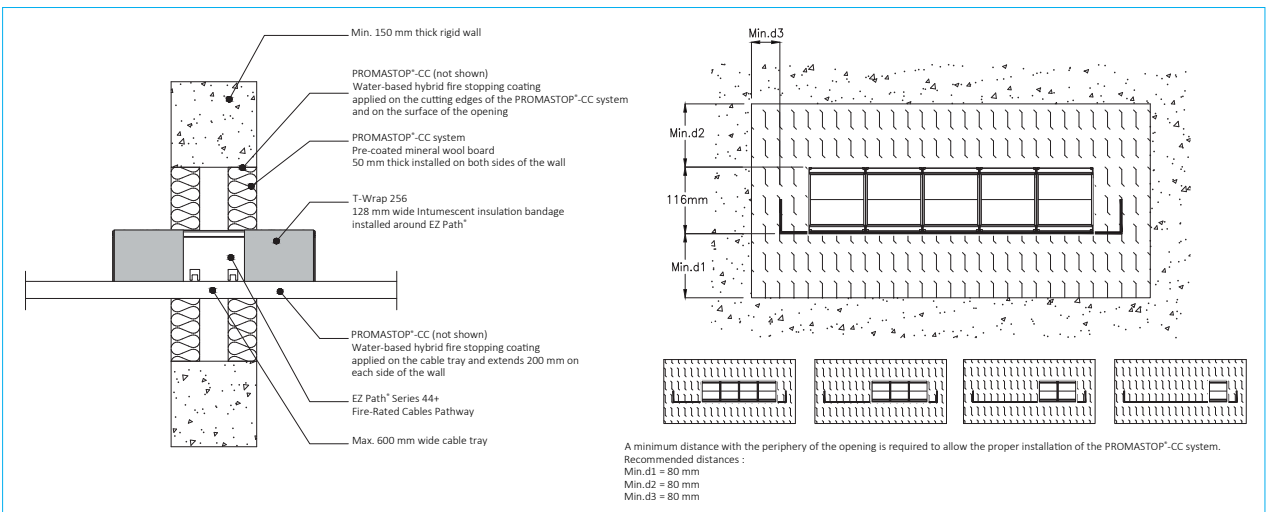

## System installation guideline

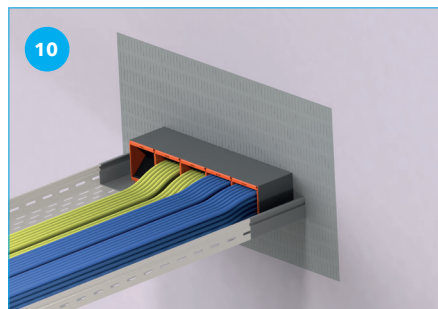
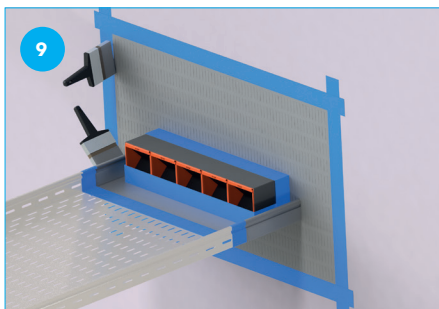
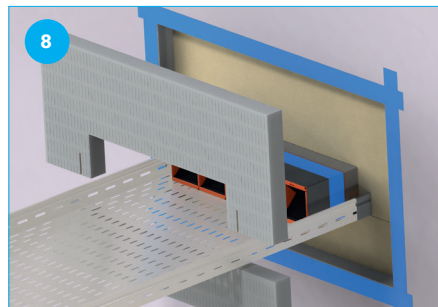
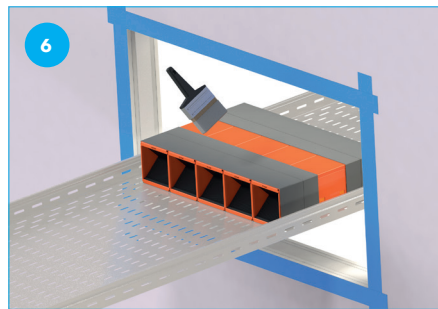
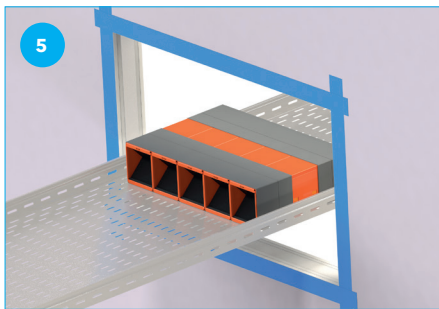
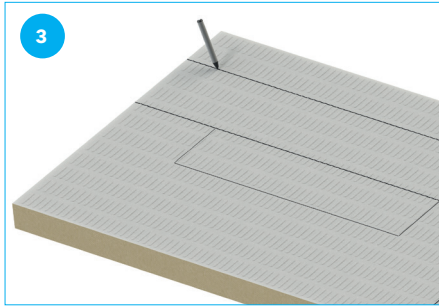
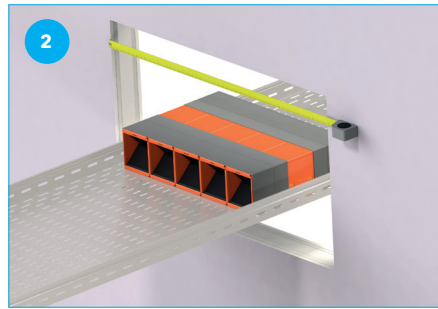
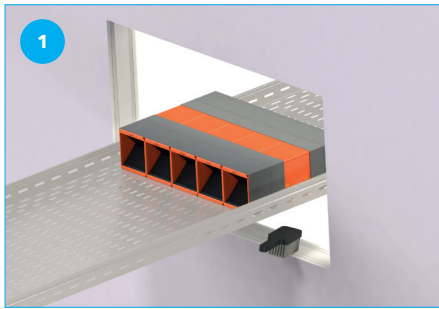

- ① Clean aperture opening, EZ-Path installed inside the cable tray and centered inside the wall (see p.3).
- ② Measure exact dimensions of opening.
- ③ Transfer measurements on mineral wool batt.
- ④ Cut the mineral wool batts exactly to size.
- ⑤ If required, mask out the working area on the wall and services with tape.
- ⑥ 1 mm thickness of PROMASTOP®-CC coating applied on the cable tray on both sides and extending 200 mm from the surface of the wall.
- ⑦ Coat the aperture opening and cutting edges of the mineral wool with PROMASTOP®-CC.
- ⑧ Insert mineral wool batts.
- ⑨ Fill all remaining joints and gaps with PROMASTOP®-CC. Repeat the same steps on the opposite side.
- ⑩ Fix identification label.

### System installation details

Please refer to the classification report for installation details.

Promat® selector  
Your selection of fire protection solutions



The products must be applied in accordance with regulations for construction material in general and fire stopping in particular, with the applicable classification reports and approvals and in accordance with applicable national building regulations. Products may only be applied by trained professionals with adequate knowledge and only after thorough review of the installation guidelines, safety data sheets, classification reports and approvals. For additional information on how and where to use this product please contact our Technical Excellence Center.

## Temporary results pending confirmation from WarringtonFire

				Electrical cables Ø21 mm	Telecommunication / Data cables	Flame passage integrity
1	6 x EZD44T2	PROMASTOP®-CC	Rigid ceiling Thickness 150 mm	EI 90	EI 120	E 240
2	7 x EZD33T2	PROMASTOP®-CC	Lightweight plasterboard partition Thickness 100 mm	EI 90		
3	6 x EZD44T2	PROMASTOP®-CC		EI 120		
4	6 x EZD44T2	PROMASTOP®-CC	Sandwich panel Thickness 100 mm	EI 120		

EZ Path® is a brand and is manufactured by Specified Technologies Inc. (STI)  
EZ Path® is distributed exclusively by Legrand® in Europe

A series of horizontal dotted lines for writing notes.



# Promat

Etex Building Performance B.V.  
Velmolenweg 85  
5401 HL Uden  
Nederland

[techniek@etexgroup.com](mailto:techniek@etexgroup.com)

[promat.com](https://promat.com)

© 2024 Etex Building Performance B.V.

07/2024