

PASSIVE FIRE PROTECTION SYSTEMS Application & Technical Manual: Penetration Seals





Counter clockwise from above

PROMASEAL® Retrofit Collars as plastic pipe penetration seals through concrete walls at National University of Singapore, general services penetration seals in masonry walls with PROMASEAL® Pillows at the Ingham Enterprises poultry factory in northern Adelaide, South Australia and electrical cables penetration seals through concrete floors with PROMASEAL® Bulkhead Sealer in the Lok Tung House building of Lok Fu Estate, Hong Kong.

Failure Criteria

Failure is measured in terms of integrity and insulation. Stability or structural adequacy is not recorded for service penetrations, except those which are required to be loadbearing, e.g. PROMASTOP® Cement. Integrity failure occurs when cracks, holes or openings occur through which flames or hot gases can pass. This is measured in different ways, depending upon the standard used.

For instance, AS 1530: Part 4: 2005 measures integrity failure as flaming on the unexposed face for a time greater than 10 seconds as well as the cotton pad test. Other standards measure integrity failure using the same criteria but with different methods of measurement, for example, using a cotton pad, held against any gap, to see if the cotton pad ignites.

Insulation failure occurs when the temperature rise on the unexposed surface of the service, on the unexposed face of the building element 25mm from the penetration or on the seal itself exceeds 180°C. If insulation criteria cannot be waived, Promat have solutions to provide insulation criteria to copper and ferrous pipes as well as cable trays.

Fire stopping penetration seal products were introduced to complement Promat's wide range of fire resistant board systems.

Thanks in large part to the diversity of applications and ongoing test programmes the guidelines in this section are generalised in nature. It is therefore essential that the system specified or being installed is approved for use. Prior to installation, please consult Promat to confirm correct specification.

While fire resisting compartments are created to contain and prevent fire and smoke from spreading within building structures, this also presents a parallel threat as most concealed cavities between fire resisting walls and floors are interlinked. The importance of sealing gaps in this type of construction is therefore vital to ensure compartmentation works to its optimum ability to save life and property. Such gaps are typical at service penetrations through walls and floors, but also include gaps left for structural movement and gaps left due to poor workmanship.

Recognising this, the development of effective solutions to seal gaps at service penetrations has increased over the past few years and Promat has become a world leader in supplying such solutions. Note should be taken that every service passing through fire resistant building elements react in different ways to fire, so there is no single solution or product that will protect all services.

Services must be tested in accordance with the test method outlined in appropriate standards. Tests are generally carried out in accordance with the general principles of BS 476: Part 20: 1987, AS 1530: Part 4: 2005 or EN 1366: Parts 3 and 4 covering both penetration seals and linear joint seals respectively. In addition, many countries use the AS 4072: Part 1: 2005 "Components for the protection of openings in fire resistant separating elements", which specifies testing in accordance with the test method set out in AS 1530: Part 4: 2005. It is important to note that although all of the above test methods can be considered similar, there are some major differences which can affect a particular application. See pages 4 and 5 for comparison of test methods/building standards.



PROMASTOP® UniCollar® penetration seals on plastic pipe through concrete floors at Devonshire Substation in Sydney, Australia.

Application Of Test Results

Where fire tests have been conducted with services penetrating masonry walls and the like, these results may not be applied to framed walls (drywall construction) in some countries.

General Application Considerations

Openings through which services penetrate fire barriers have to be reinstated in such a manner that the fire resistance of the barrier is not impaired.

This means that if a wall or floor has a fire resistance level of 120/120/120 or -/120/120 or even -/120/30, the finished construction must have the same fire resistance. The only exception is that structural adequacy of penetration seals themselves is not measured, so the fire resistance level of the finished seal in the above systems would therefore be stipulated as -/120/120 or -/120/30.

In fire tests the temperature on the unexposed side of the specimen is measured at various locations.

This temperature is taken not only on the surface of the barrier and sealing system but also on the service itself where it is measured 25mm from the barrier.

If insulation criteria on the services is required, a tested prototype with insulation performance that matches the application is required. The test results must show that the insulation on the services meet the insulation criteria.

It is obvious in this instance that compliance on seals containing metal penetrations is difficult, as temperatures will quickly transfer by conduction through the metal elements.

Some fire tests do achieve insulation criteria on services, most commonly on penetrations consisting of cables and insulated pipes.

All barriers should maintain the insulation criteria on the base barrier system. Clause C3.15 b a (i) and (ii) in Building Code of Australia (BCA) allows the waiving of insulation on services where the service is protected such that combustible materials cannot be located within 100mm of the penetrating service for a distance of 2000mm from the penetration and it is not located within an escape exit. This waiver is currently only allowed for metal pipes and it is important to check for local interpretations of this provision.

If the service does not achieve the required insulation criteria and a certificate for the work is to be issued, the fire resistance level should be expressed as -/120/- or similar.

Where cable trays penetrate walls or floors and it is deemed necessary, the cable tray itself may be cut so that it does not pass through the barrier, thus eliminating most of the conduction through the tray. Alternatively, barriers in the form of mesh guards can be placed around the service ensuring combustibles are not placed within 100mm of the surface of the penetration services.

Please refer to [pages 6 to 54](#) for a wide range of penetration seals, fire stopping products and systems.

Where fire tests have been conducted with services penetrating framed plasterboard walls, the results may be used in conjunction with all other walls including masonry (brick), cement/concrete blocks, lightweight aerated concrete blocks, prefabricated plaster walls, plaster blocks, PROMATECT®-H, PROMATECT® 100, PROMINA® 60, PROMINA®-HD and other walls constructed from these boards, provided that:

- 1) The total wall thickness is no less than the thickness of the tested prototype;
- 2) The board system uses the same number of layers of board as used in the tested prototype, or must be covered by an assessment from a registered testing authority;
- 3) The wall may be locally thickened for compliance to above no. 1 and 2 by applying additional layer(s) of board around the penetrating service;
- 4) The sealant is applied in the same manner as the tested prototype;
- 5) The sealant is at least as deep as that applied in the tested prototype;
- 6) The required fire resistance is no greater than the tested prototype;
- 7) The fire resistance of the barrier is no less than the required fire resistance of the penetration;
- 8) The tested service penetration achieves at least the same fire resistance level as the wall or floor being sealed.

Please check with local regulations before specifying or installing penetration sealing systems to ensure local compliance.

If the fire resistance level of the separating element of construction through which the penetrating service passes is not known, the only choice is to state that the penetration sealing system will perform for as long as the separating element retains its integrity and insulation, or for as long as the approved fire resistance level of the penetration sealing system (whichever period of time is less).

Where fire tests have been conducted with services penetrating a concrete floor, the results may be used in floors of similar or greater fire resistance and thickness.

NOTE:

- BCA does not address the issue of smoke leakage through building elements (e.g. floors, walls and any service penetration passing through);
- Service penetrations should always be installed and tested in a manner representative of their intended purpose.

For more information regarding standards, please refer to BS 476: Part 20: 1987, BS EN 1366: Part 3: 2009, AS 1530: Part 4: 2005 and AS 4072: Part 1: 2005.

User Guide To Systems

As penetrations can occur in various building elements, there are a number of important criteria that require consideration in determining the appropriate type of sealing system to be used, and this is simplified in the following chart:

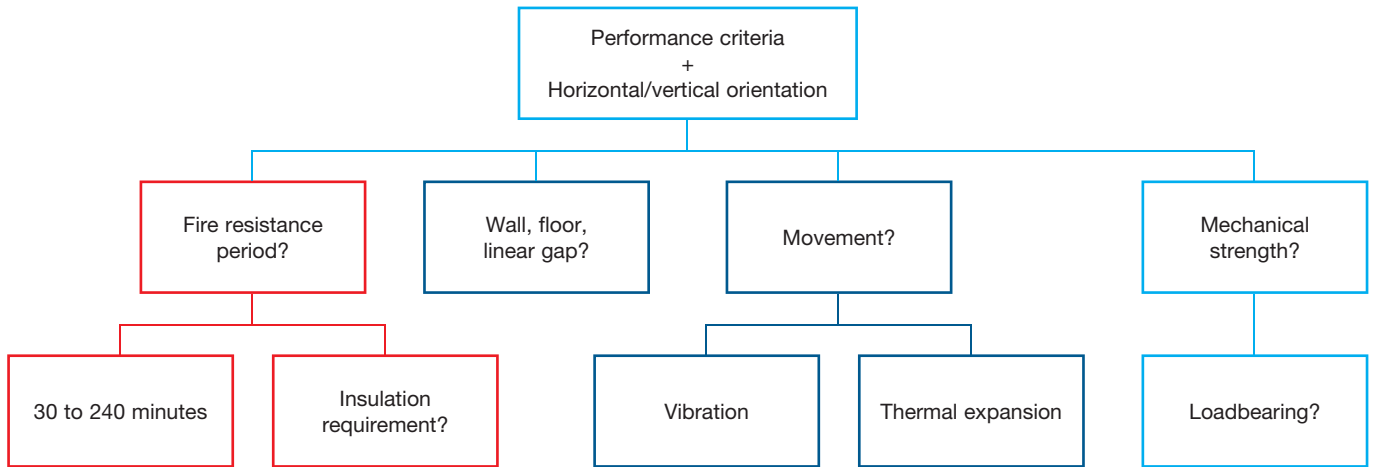

Limitations Of Use

- Size of opening
- Penetration services
- Flexibility of seals
- Smoke or gas tightness
- Ambient conditions
- Design life
- Frequency of change to services
- Parent construction (type of substrate)

Special Considerations

In instances where electrical and mechanical services are involved, the selection of penetration sealing system also require the following additional elements to be carefully considered.

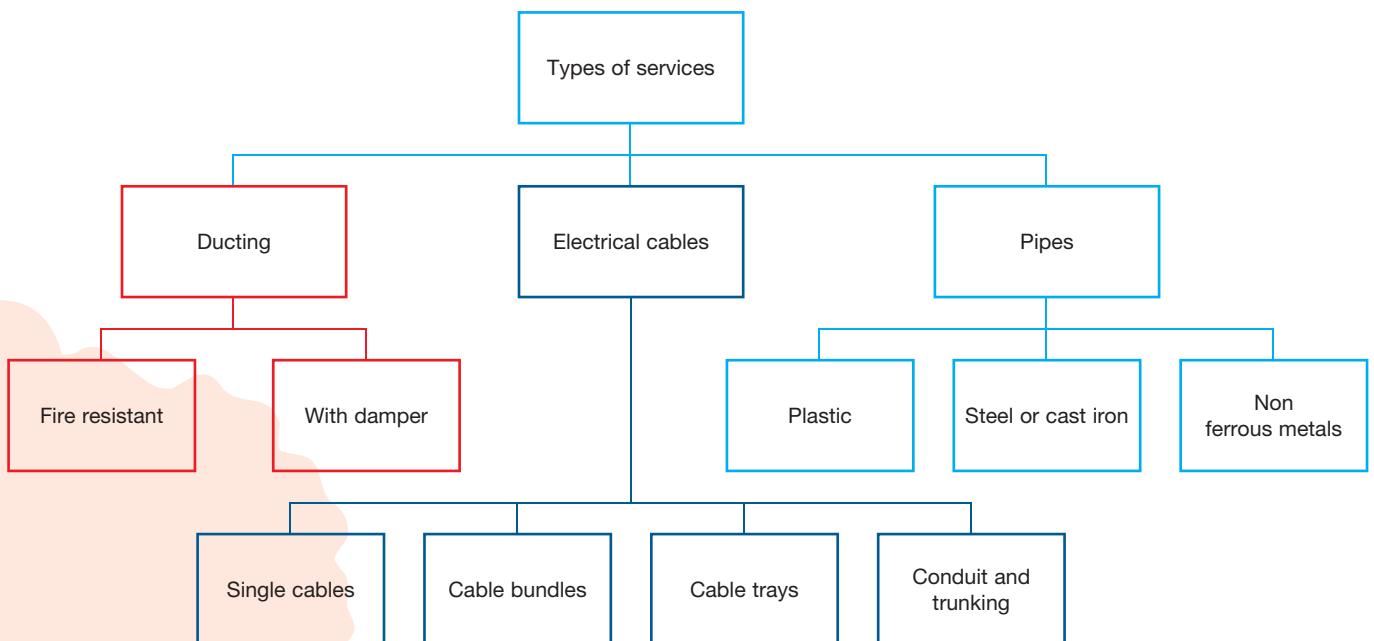

Compatibility Considerations

- Intumescent systems in lightweight constructions
- Rigid seals in “dynamic” barriers
- Large spans and thermal expansion
- Smoke or toxicity in populated zones
- Dusty or friable materials in “clean room” applications



	British Standard BS 476: Part 20: 1987	European Standards BS EN 1366: Part 3: 2009 and BS EN 1366: Part 4: 2010	Australian Standards AS 1530: Part 4: 2005 and AS 4072: Part 1: 2005	United States Standards ASTM E814: 2011 and UL 1479: 2006
Orientation	Requires representative specimen in both orientations. For asymmetrical specimens, a test should be conducted from each side using separate specimens.	Representative or standard service configurations tested both in horizontal and vertical orientation.	Requires full size or representative specimen and testing in both horizontal and vertical orientation if intended for use in both orientations. Provide standard test configurations.	UL requires both orientations to be tested unless it can be demonstrated that testing in a single orientation does not affect the results. ASTM does not specify but there are differences in temperature and pressure measurements for the two orientations so that, by default, both would be required.
Test sample	Does not specify projection distances of through penetrating elements. The end conditions of pipes should reflect the "as installed" conditions.	For the purpose of tests, joints may be formed on monolithic slabs or by adjacent discrete members. The linear joint seal shall have a minimum heated length of 900mm. A test construction may incorporate several discrete linear joint seals, evaluating performance of different system of the effect of different joint face substrates, providing the following conditions are met: a) Minimum distance between adjacent seals on the exposed sides shall not be less than 200mm. On the unexposed side, the minimum distance between adjacent seals shall not be less than 200mm. b) The test construction can either be inserted in the furnace opening or put onto the furnace walls. The minimum width of the supporting elements adjacent to the edges of the furnace opening shall be such that a distance of at least 200mm exists between the longitudinal edge of the linear joint seal and the interior furnace face. The minimum distance between a joint edge and an adjacent knockout edge shall be at least 200mm.	The ends of the services shall be sealed on the exposed side of the furnace, to simulate normal extension through compartment. The penetrating element shall extend 500mm into the furnace and 2000mm outside the furnace for plastic pipes, all other elements are 500mm inside and outside the furnace.	The penetrating element should extend into the furnace by 300mm and out of it by 910mm. The end of the element on the exposed face is capped, but uncapped on the unexposed side, unless it is to represent a closed system in which case it may be capped. The periphery of the specimen should not be closer than 1.5 the thickness of the assembly, or 300mm to the furnace edge, whichever is greater.
Conditioning	Materials shall, at time of test, be in a condition approximating the state of strength and moisture content that would be expected in normal service.	The test specimens shall not be tested until both strength and moisture content approximate the values the service expects to attain.	The test specimens shall not be tested until both strength and moisture content approximate the values the service expects to attain.	Prior to fire testing, each test sample and test assembly is to be conditioned, if necessary, to provide a moisture condition likely to exist in similarly constructed buildings.
Protection of assembly and sample	Ambient temperature should be within 5-35°C prior to heating period, and temperature measurements on the unexposed face must be in draught free conditions.	Provided reference for test frames and ambient conditions are in 20°C ± 10°C at commencement of test. During testing, the laboratory temperature shall not decrease >5°C or increase by >20°C for all insulated separating elements while they still satisfy insulation criterion.	Not specified except that the initial furnace temperature must be not less than 10°C and not more than 40°C.	The testing equipment and test sample are to be protected from any condition of wind or weather that might influence the test results, i.e. ambient temperature at the time of testing must be within 10-32°C while the velocity of air across the sample must not exceed 1.3m per second.
Pressure differential	At mid height of vertical systems, the pressure differential is 15Pa. In horizontal systems, it is the same pressure different but 100mm below mid height.	A vertical furnace shall be operated so that a minimum pressure of 15Pa exists in the centre of the test specimen mounted in the lowest position. A horizontal furnace shall be operated so that a pressure of 20Pa + 3Pa is establishes at a position 100mm + 10mm below the lowest point of the test construction.	Not less than 20Pa at notional 100mm below the soffit height of horizontal element or at a level with lowest point of the penetration seal of a vertical element it should be 15Pa ± 3Pa.	Except for the first 10 minutes of the test, the furnace pressure shall be at least 2.5Pa greater than the pressure on the unexposed side of the following locations: a) at lowest elevation of the test specimen for walls, b) at the location of the pressure probes for floors. Test sponsor may also specify a unique pressure condition in which case it must be maintained throughout the duration of the test, excluding the first 10 minutes, within 20% of the specification.



	British Standard BS 476: Part 20: 1987	European Standards BS EN 1366: Part 3: 2009 and BS EN 1366: Part 4: 2010	Australian Standards AS 1530: Part 4: 2005 and AS 4072: Part 1: 2005	United States Standards ASTM E814: 2011 and UL 1479: 2006
Integrity	<ul style="list-style-type: none"> a) Cotton pad test, b) gap gauge, and c) sustained flaming of more than 10 seconds. 	<ul style="list-style-type: none"> a) Cotton pad test is generally performed, the use of reduced size cotton pad is permitted for penetration seal tests if necessary; b) whilst gap gauge is used for measurement in general test specimens, it shall not be used for evaluation of penetration and linear joint seals tests; c) flaming takes place at the unexposed face of the specimen for a period exceeding 10 seconds. 	<p>Failed when:</p> <ul style="list-style-type: none"> a) Cotton pad test is generally performed, the use of reduced size cotton pad is permitted for penetration seal tests if necessary b) whilst gap gauge is used for measurement in general test specimens, it shall not be used for evaluation of penetration and linear joint seals tests. 	<p>Shall not permit the passage of flame throughout the fire test, or water through the hose stream test. Mandatory for all ratings in both standards, i.e. ASTM and UL.</p>
Insulation	<p>The insulation of the specimen is judged to have failed if the temperature on the unexposed side and on penetrations reaches 180°C above the initial temperature.</p>	<p>The insulation of the specimen is judged to have failed if the temperature on the unexposed side and on penetrations reaches 180°C (K) above its initial temperature.</p>	<p>The criteria for failure of insulation is if the temperature of any of the thermocouples on the unexposed side reaches 180°C above the initial temperature.</p>	<p>Shall not permit the passage of flame through the fire test, or water through the hose stream test or allow the temperature to increase by 180°C on the unexposed side. Mandatory for T rating in both standards.</p>
Hose stream test	<p>No specification.</p>	<p>No specification.</p>	<p>No specification.</p>	<p>For both F and T ratings, a duplicate specimen is subject to a fire exposure test for period half of the desired rating but not more than 60 minutes. Immediately after the fire exposure, the specimen shall be subject to the hose stream test. Same test assembly can be used for both tests but must take place within 10 minutes from the completion of the fire test.</p>
Specification	<ul style="list-style-type: none"> a) Integrity, b) insulation, and c) loadbearing capacity where applicable. 	<ul style="list-style-type: none"> a) Integrity, b) gap gauge (not applicable for penetration and linear joints seal tests), c) cotton pad, d) insulation, and e) second insulation area (if the test element incorporates two discrete areas of different thermal insulation). 	<p>AS 1530: Part 4 states results to be expressed in:</p> <ul style="list-style-type: none"> a) integrity, and b) insulation. 	<p>An F rating based upon flame occurrence on the unexposed side of the test sample and acceptable hose stream performance; and a T rating based on temperature rise and flame occurrence on the unexposed side of the test sample and acceptable hose stream performance.</p> <p>An L rating is based on the amount of air leakage through the test sample.</p> <p>A W rating is based on the water resistance of the test sample.</p>
Reporting	<ul style="list-style-type: none"> a) Temperature data from all specified critical thermocouple, b) a detailed description of all penetrating services, and c) a detailed description of the test construction. 	<p>In addition to the items required by EN 1363: Part 1, the following shall be included in the test report:</p> <ul style="list-style-type: none"> a) A full description of any procedure used to induce relative movement of the linear joint seal faces, when tested as described in Annex B, b) the test specimen orientation, c) the limits of the range of nominal widths and the movement capability successfully tested, d) a full description of the splicing methods used, and e) a presentation in graphs if relevant. 	<p>In addition to the requirements of AS 1530: Part 4, the report should have:</p> <ul style="list-style-type: none"> a) temperature data from all specified critical thermocouple, b) a detailed description of all penetrating services, and c) a detailed description of the test construction. 	<p>Report must have:</p> <ul style="list-style-type: none"> a) description of assembly and materials, b) relative humidities, c) temperature recordings, d) the achieved rating, e) location of pressure probes and differential pressure of the test, f) record of all observations, and g) correction factor.
Commentary	<p>For positions of thermo-couples and other items not specified in this standard, laboratories refer to the EN standard.</p>	<p>These standards are now in effect for use within the industry.</p>	<p>Comprehensive and simple standard configurations, as well as details on permissible variations.</p>	<p>UL also have an addition L rating which is to be reported as the largest leakage rate determined from the air leakage test.</p>



Type	Product	Maximum fire resistance performance	Area of penetration seals or sealing	Page no.
Plastic pipe penetration seals	PROMASTOP® UniCollar®	-/240/240	Concrete/masonry floors and walls, partitions	10-12
	PROMASEAL® Conduit Collar	-/240/240		
Plastic pipe penetration seals	PROMASEAL® Retrofit Collar (square base)	-/240/240	Ceilings, concrete/masonry floors and walls, partitions	13-15
	PROMASEAL® Retrofit Collar (circular base)	-/240/240	Concrete/masonry floors and walls	
Plastic pipe penetration seals	PROMASEAL® Wall Collar	-/120/120	Concrete/masonry walls, partitions	16
Plastic pipe penetration seals	PROMASEAL® Hi-Blu Collar	-/240/240	Concrete/masonry floors	18, 19
	PROMASEAL® Green Cast-in Collar	-/240/240		
Plastic pipe penetration seals	PromaSnap® Floor Waste System	-/120/120	Concrete/masonry floors	20, 21
Plastic pipe penetration seals	PROMASEAL® Retrofit Floor Waste Collar	-/240/180	Concrete/masonry floors	22
Electrical services penetration seals	PROMASEAL® Services Seal Collar	-/180/120	Concrete/masonry floors	23
Plastic pipe penetration seals	Promat PipeSeal® Cast-in Collar	Non fire resistant	Concrete/masonry floors	24
Electrical services penetration seals	Promat MultiSeal® Cast-in Collar	Non fire resistant	Concrete/masonry floors	25
Various penetration seals	PROMASEAL®-A Acrylic Sealant	-/120/-	Metal pipes in concrete/masonry floors and walls	28-32
		-/180/-	Electrical cable trays in concrete/masonry walls, partitions	
		-/240/-	Steel ventilation ducts in concrete/masonry walls, partitions	
		-/240/240	Control joints and gaps in ceilings, concrete/masonry floors and walls, partitions	
Seals of joints and gaps, and various penetration seals	PROMASEAL® IBS™	-/240/240	Ceilings, concrete/masonry floors	33-37
		-/240/240	Concrete/masonry walls, partitions	

NOTE: See the next page.



Type	Product	Maximum fire resistance performance	Area of penetration seals or sealing	Page no.
 <p>Seals of movement joints</p>	PROMASEAL® FyreStrip	-/240/240	Concrete/masonry floors	38, 39
		-/240/240	Concrete/masonry walls	
 <p>Various penetration seals</p>	PROMASEAL® Bulkhead Sealer System	-/120/120	Concrete/masonry floors	40-43
		-/120/120	Concrete/masonry walls	
 <p>Various penetration seals</p>	PROMASEAL® Cement	-/360/360 (loadbearing)	Concrete/masonry floors	44-46
		-/240/240	Concrete/masonry walls	
 <p>Various penetration seals</p>	PROMASEAL® Mortar	-/240/240	Concrete/masonry floors	47-52
		-/240/240	Concrete/masonry walls	
 <p>Copper pipe penetration seals</p>	PROMASEAL® FlexiWrap	-/240/120	Concrete/masonry floors	53
		-/240/120	Concrete/masonry walls, partitions	
 <p>Plastic pipe penetration seals</p>	PROMASEAL® Graitex	-/240/120	Concrete/masonry floors	54
		-/240/120	Concrete/masonry walls	
 <p>Seals of electrical cable trunking</p>	PROMASEAL® Electrical Junction Seal	-/120/120	Concrete/masonry floors	55
		-/120/120	Concrete/masonry walls	
 <p>Metal pipe and electrical cable trunking penetration seals</p>	PROMASEAL® Pillows	-/180/180	Concrete/masonry floors	56, 57
		-/180/180	Concrete/masonry walls, partitions	
 <p>Switchbox intumescent</p>	PROMASEAL® Switchbox Intumescent	-/120/120	Concrete/masonry walls, partitions	58

NOTE: The insulation values may relate only to the seal itself or to the penetrating/building elements. Please contact Promat for clarification and the test/approval number of assessment report relating to the above systems if necessary.

Promat fire collars are manufactured using intumescent technology. These collars are designed to maintain the integrity of the fire resistant element through which plastic pipes, combustible insulation, cables or fibre optic facilities pass. Promat fire collars are suitable for installation in the various types of floors, walls and ceilings in which they have been tested.

In the event of fire, the plastic pipe will start to deform. In the case of uPVC pipes this occurs at a temperature of approximately 70°C. Once the pipe starts to deform, the intumescent material in the Promat fire collar expands, closing off the plastic pipe or combustible insulation, and thus forming an insulating barrier.

This intumescent compound continues to expand throughout the fire and forms a char which prevents flame and hot gases passing into adjacent compartments.

It is important to know that there are many different kinds of plastic and their behaviour in fire situations can vary significantly. This means that fire collars have to be tested on particular types and sizes of pipe to ensure their efficacy in the event of a fire.

Some examples of typical plastic pipes are:

- Acrylonitrile butadiene styrene (ABS)
- High density polyethylene (HDPE)
- Poly butylene (PB)
- Poly propylene (PP)
- Poly propylene random (PPR)
- Unplasticised poly vinyl chloride (uPVC)
- Cross linked polyethylene (XLPE)
- Polyethylene, aluminium and polyethylene (PE/AL/PE)

Recent technology and the price of copper has seen the development of composite pipes using plastics combined with aluminium layers. It is important to note the combinations (of plastics, aluminium and other materials) before recommending a particular type or size of collar. PE/AL/PE is a good example. This means that the inner layer is polyethylene, the middle layer is aluminium and the outer layer is again, polyethylene. These types are mainly used for gas supply piping.

AS 1530: Part 4: 2005 is very specific regarding plastic pipes; it states that where a fire collar has been tested on the range of uPVC pipes, including 40, 50, 65, 80 and 100, and achieved the required fire resistance performance. It can be used on other types of plastic provided that the smallest and largest pipes from that particular family of plastics has been successfully tested and that a registered/accredited testing laboratory has assessed it.

It is important to understand why this is so. Different plastic pipes behave in very different ways when subject to the same fire resistance testing. As an example, uPVC, being a thermosetting plastic, will form a rigid char once it has been subject to a fire. On the other hand, the thermoplastic HDPE will not form a char. It will in fact melt and drip, enhancing its ignitability.

Some building regulations and test standards are more lenient than the Australian equivalents and do not require the same degree of strict testing and approvals with all types of plastics.

If overseas test reports are used in the jurisdiction of other countries, it is vital to check that those test standards are comparable with both AS 1530: Part 4: 2005 and AS 4072: Part 1: 2005. In many cases they are not comparable.

Floor Wastes And Stacks

It is important to understand the difference between floor waste and stacks. The standard AS 1530: Part 4: 2005 discusses this difference in detail. Typical floor wastes are grates in the floor which allow a flow of water to drain into and through them. They are normally found in shower, floor and laundry waste applications and must be tested in that orientation.

Stack testing is used for whenever there is any length of pipe above the floor slab. The test demands that there be a 2000mm length of pipe above the slab. It is considered that this is the most onerous method of test because the 2000mm of pipe (stack) creates a chimney effect, drawing the fumes and hot gases through the length of pipe. Please note that sinks, toilets, baths etc are considered stacks and should be tested with the 2000mm of pipe exposed above the floor slab.

For a complete test/approval number of assessment report relating to floor waste collars, please contact Promat.

Floor Application

There are SEVEN (7) types of floor collars:

- 1) Square based PROMASEAL® Retrofit Collar (FC type) fits around the plastic pipe on the underside of a floor. It is bolted to the slab. However, it can be used as cast-in collar as well. Please note, new collars in the Australian market generally satisfy this method of installation.
- 2) Circular based PROMASEAL® Retrofit Collar (FCS type) has a larger opening than the FC type and is designed and tested to be retrofitted to floors. It can accommodate a pipe fitting if required and can also be used for lagged plastic drink lines.
- 3) PROMASEAL® Hi-Blu Collar is cast-in fitted with smoke and water seals.
- 4) PROMASTOP® UniCollar® and PROMASEAL® Conduit Collar.
- 5) PROMASEAL® Green Cast-in Collar is designed to be fixed to formwork prior to pouring concrete floors. This collar accommodates the pipe fitting within the soffit of the slab, enabling space savings to be achieved. The collar will close both the pipe and pipe fitting in a fire. PROMASEAL® Green Cast-in Collars have been successfully tested up to 180 minute fire resistance with uPVC and HDPE pipes for floor waste stacks.
- 6) PromaSnap® Floor Waste System has been tested up to 120 minute fire resistance with uPVC pipes and fittings for floor waste applications. The system has been designed to provide an effective, simple solution for water proofing and the levelling of the screed for tiling and water flow from the floor.
- 7) PROMASEAL® Retrofit Floor Waste Collar has been tested and approved for floor wastes where integrity and insulation criteria are required.

Wall Application

There are THREE (3) types of wall collars:

- 1) Square based PROMASEAL® Retrofit Collar (FC type) as described above. This collar fits around the plastic pipe on both sides of lightweight walls (e.g. plasterboard, PROMATECT® 100) or the fire side of masonry walls. This collar does not require fitting.
- 2) PROMASEAL® Wall Collar is a canister that fits around the pipe and slides centrally into the cavity of the wall. Thus only one collar is necessary to provide fire resistance from either direction. This collar is generally used for steel/timber framed lightweight partitions but can also be applied in masonry walls.
- 3) PROMASTOP® UniCollar® and PROMASEAL® Conduit Collar.

Ceiling Application

There are TWO (2) types of ceiling collars:





- 1) Square based PROMASEAL® Retrofit Collar (FC type) is fitted through the underside of the ceiling to the steel framing above.
- 2) PROMASTOP® UniCollar® is directly screwed into plasterboard.

Guide To Fixings

The section is to clarify the issues with regards to the use of the correct fixings currently available in the market place for fire collars and explain the differences between them. It is essential that fire collars are only installed with the correct size ALL STEEL fixings. In the past alloy based fixings have been tested and have shown that they will not provide the required fire performance.

Currently some fixing products available are marketed as all metal, or zinc alloy. These type of anchors need to be thoroughly checked because some of them have other alloys included in the matrix of the fixing and these can melt at lower temperatures than those found in cellulosic fires, thus rendering them inappropriate for supporting fire resistant devices such as fire collars.

Examples of all metal, zinc alloy anchors etc:

Ramset's Shuredrive		Hilti's HD metal drive anchor	
Macsim's Macdrive		Power's metal pin anchor	

NOTE: The above anchors are not suitable as fixings for PROMASEAL® and PROMASTOP® fire collars unless there are test approvals.

Examples of all steel anchors:

Ramset's Dynabolt		Macsim's DBZ metal pin anchor	
Ramset's Trubolt		Macsim's Masonbolt	
Ramset's Redidrive		Power's sleeve anchor	
Hilti's DBZ		Power's Powerbolt	
Hilti's HSA Stud Anchor		Power's PBZ wedge anchor	

NOTE: The above anchors are suitable as fixings for PROMASEAL® and PROMASTOP® fire collars in accordance with tables below.

Concrete walls or floors	Plasterboard walls
Fire collars should be installed on both sides of the wall	
<p>For PROMASTOP® UniCollar® installed into concrete walls or floors, steel fixings are supplied within the collar packaging and the collars should be installed with the requisite number of brackets depending upon the pipe size.</p> <p>For square or circular based PROMASEAL® Retrofit Collars (FC or FCS type) installed into concrete walls or floors, steel fixings must be installed using all the collar fixing points with the following sizes:</p> <ul style="list-style-type: none"> For collars up to 150mm, 25mm minimum length steel anchors as listed above should be used. For collars from 150mm to 315mm, minimum 38mm x 6mm steel expanding anchors must be used, as per Ramset Dynabolt or similar. 	<p>For PROMASTOP® UniCollar® installed into plasterboard walls, 40mm x No.10 laminating screws are supplied within the collar packaging and should be installed with the requisite number of brackets depending on the pipe size.</p> <p>For square or circular based PROMASEAL® Retrofit Collars (FC or FCS type) installed into plasterboard walls, steel fixings must be installed using all the collar fixing points and using the following fixing size:</p> <ul style="list-style-type: none"> For collars up to 150mm, 40mm x No.10 laminating screws should be used. For collars above 150mm, framing should be placed within the wall at locations where the following rods pass through. 8mm diameter threaded rod must pass from one side of the wall to the other and washers and nuts should be placed onto the ends of the rods where they pass through the fixing points of the collar.

Plasterboard ceilings	
PROMASEAL® Retrofit Collars, up to 160mm	PROMASTOP® UniCollar®, up to 110mm
<p>Square or circular based PROMASEAL® Retrofit Collars (FC or FCS type) can be installed onto uPVC and HDPE in 60-120 minute fire resistant ceilings. Use PROMASEAL®-A Acrylic Sealant to seal annular gaps. Provide additional framing to support the collar.</p> <p>Fix the collar through the plasterboard and into the framing above. The gap between the ceiling lining board and the pipe should be no more than 15mm and sealed with PROMASEAL®-A Acrylic Sealant to the full depth of the lining board.</p>	<p>PROMASTOP® UniCollar® can be installed into fire resistant plasterboard ceilings that provide a similar fire resistance.</p> <p>For 90 minutes integrity and 60 minutes insulation fit the collar to the ceiling lining with 10g x 40mm coarse thread screws, use 2 brackets for pipes 40-69mm and 3 brackets for pipes 70-110mm.</p> <p>For 90 minutes integrity and 90 minutes insulation fix the collar as above but install one layer of PROMATECT®-L500 board locally above the collar friction fitted between the joists.</p>

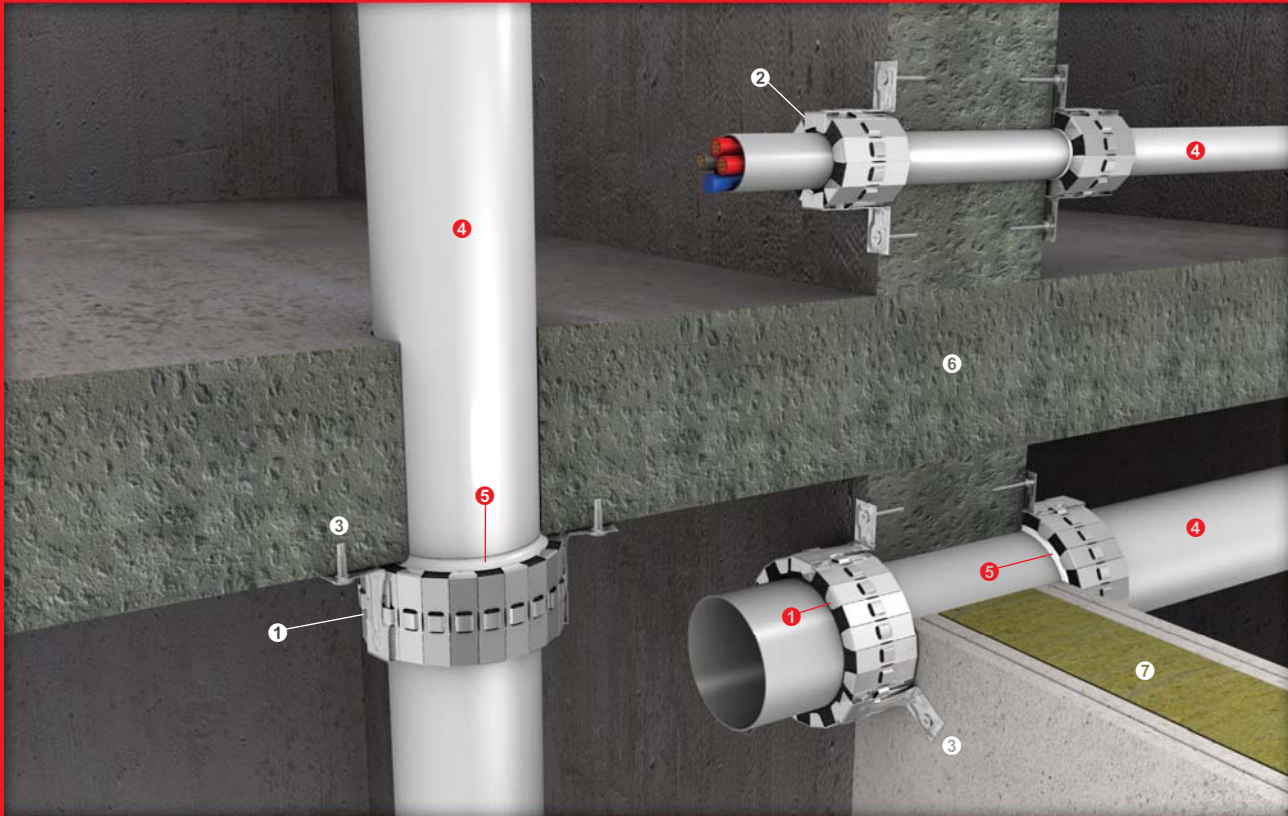

Up to -/240/240 fire resistance in accordance with the requirements of BS 476: Part 20: 1987 and AS 1530: Part 4: 2005; insulation criteria will vary depending on type and size of plastic pipes AND the type of penetrating elements

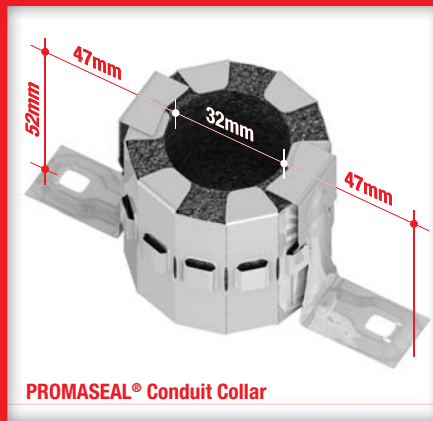

- ❶ PROMASTOP® UniCollar®
- ❷ PROMASEAL® Conduit Collar
- ❸ Brackets attached with suitable fixing, i.e. steel bolt anchors for masonry/concrete floors and walls OR laminating screws for lightweight partitions
- ❹ Various plastic piping
- ❺ All gaps caulked with PROMASEAL®-A Acrylic Sealant to achieve the required fire resistance performance
- ❻ Fire resistant concrete/masonry floors or walls
- ❼ Fire resistant steel/timber framed lightweight partitions

Usage guide

Inside diameter (I/D)	mm	43	50	55	63	69	75	83	90	110	114	125	140	160	200
	inches	1.25	1.5	-	2	-	2.5	-	3	-	4	-	5	6	-
Segments per collar (UL listing if featured)		15	17	18	20 (19)	21	22	24	25	29	30	33	36	40 (42)	49
Approximate number of collars per box		10	8.5	8	7.5	7	6.5	6	6	5	5	4.5	4	3.5 (3.75)	3
Number of brackets per collar for floor application		2	2	2	2	2	3	3	3	3	3	4	5	5	5
Number of brackets per collar for wall application		2	2	2	2	2	3	3	3	3	3	3	5	5	5

PROMASTOP® UniCollar®

PROMASTOP® UniCollars® are a fire stopping device containing intumescent material designed to maintain the integrity of the fire resistant element through which plastic pipes pass. The collars are suitable for installation in various floors and walls similar to that in which they have been tested.

In the event of a fire, the intumescent material in PROMASTOP® UniCollar® rapidly expands, closing off the plastic pipe or combustible insulation and forming an insulating barrier. This intumescent compound continues to expand throughout the fire and forms a non combustible char which stops the fire passing into adjacent fire compartments.

However, it is important to note that there are many different kinds of plastic and they react to fire in different ways. This means that fire collars may have to be tested on many types and sizes of pipe. Please note that local regulations must be accurately assessed if this is appropriate or necessary. Examples of plastic pipes are uPVC, HDPE, PP, PPR, ABS, PE and Pex/Al/Pex.

At time of this publication, there is no British Standard covering this specific section of fire stopping. Nevertheless, the general conditions of BS 476: Part 20: 1987 are used to evaluate penetration seals.

Australian Standard AS 4072: Part 1: 2005 "Components for the protection of openings in fire resistant separating elements. Part 1: service penetrations and joints" calls for all types of plastic pipe and all sizes to be tested. This means that any assessments written to AS 4072: Part 1: 2005 must be able to refer to tested specimens that clearly show the type of plastic has been tested with the collar in the same orientation and size as to be used in practise.

It is currently acceptable to test new types of plastic using uPVC as a benchmark.

PROMASTOP® UniCollar® has undergone fire tests in numerous countries around the world to many standards. Please contact Promat to check if the approval of the required application is already covered.

Packaging

PROMASTOP® UniCollar® is packaged in individual boxes each containing 2250mm length of collar or 150 segments. The collar is designed so that it can be cut and snapped in modules of 15mm.

One box contains the equivalent of 5 x 110mm collars. Please see table on [page 10](#) for a usage guide to the approximate number of collars and brackets each full length of PROMASTOP® UniCollar® equates to in most typical on-site applications.

The table shows the suggested lengths of collar (segments) required for various inside diameters (I/D) of plastic pipes. In difficult situations it may be necessary to use longer lengths of collar to assist with installation.

The number of collar units per box may vary depending on installer's skill and attention to detail.

At time of this publication, tests have not been carried out on plastic pipes greater than 200mm outside diameter. Please consult Promat for details of such applications.

For uPVC pipes with 110mm outside diameter or less, add two segments if the collar has to fit around a pipe joiner.

Removing Casing And Accessories

Each package of PROMASTOP® UniCollar® contains the fixings and other accessories required for installation (see pictures on [page 12](#)).

Please read the information in this manual in conjunction with the diagrams printed on the rear of the package and use of the measuring tape provided as an accessory in the package:

- Open the package at the position clearly marked with an arrow.
- Remove the accessories box before pulling out one end of the PROMASTOP® UniCollar®. The collar strip will uncoil.

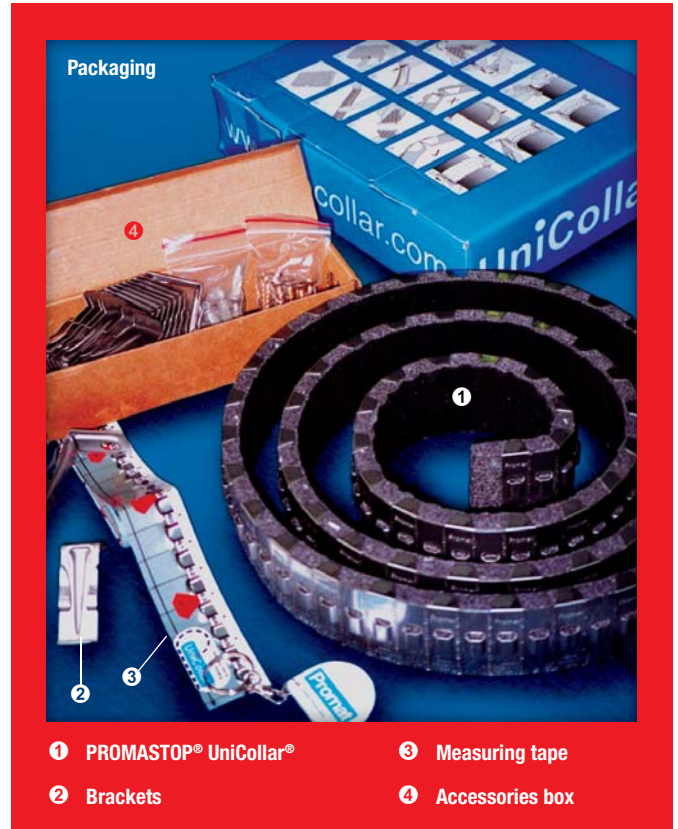

1 PROMASTOP® UniCollar® 3 Measuring tape
2 Brackets 4 Accessories box

- Ensure the soft Graftex side of the collar strip faces up. The steel has perforations to ease the snapping of the length located at 15mm centres.
- Use only sufficient length (segments) required of the collar from the package. For example, approximately 600mm of a segment pulled out is adequate and convenient for a 110mm cut of the collar.

Cutting/Snapping The Collar

- Correctly identify the required outside diameter of the plastic pipes to which the PROMASTOP® UniCollar® will be applied. The diagrams printed on the package provide concise information on the number of segments required for various sizes of plastic pipes.
- Either count the number of the 15mm segments required or measure the collar strip using the tape provided. One side of the measuring tape is marked with each pipe size. The correct number of segments and directions are clearly indicated on the other side of the tape.
- Hold the measuring tape on the collar strip and align both ends of the tape and the strip.
- Cut through the soft Graftex side of the collar strip at an appropriate position, e.g. cut at segment 29 for a 110mm outside diameter pipe. It is important to note that, for safety purpose, the strip should be cut in an opposite direction from fingers at all times and this exercise should be performed in a consistent manner.
- Hold the collar strip between finger and thumb on each side and as close as possible to the desired cut section. Fold in a downward direction as far as possible. The cut Graftex will open. Repeat the folding and unfolding sequence until the steel snaps.

PROMASEAL® Conduit Collar

For plastic conduits with 32mm diameter or less, the PROMASEAL® Conduit Collar has been tested up to 240 minute fire resistance in floors and walls. The collar is fixed to the floors/walls with two brackets.

Insulation criteria will vary depending on types of the plastic pipes and the penetrating building element through which the collar passes.

For the limited diameter required, only one size of 32mm PROMASEAL® Conduit Collar is available and prefabricated from Promat. It can be purchased individually.

Assemble The Collar

- Both cut ends of the Grafitex should be square. For easier fixing, cut these square ends to a slight angle. Shape the cut collar section (casing) to the approximate outside diameter of the plastic pipe. For small pipes (e.g. < 75mm), pay attention to the square ends of these casings to ensure they have been shaped correctly.
- Push one of the prongs of a bracket through the notch at one end of the casing. Fold the casing around the plastic pipe and push the other prong through the notch at the other end of the casing. If pushing is difficult, the bracket can be gently hammered into position. Attach this bracket followed by others onto the floor/wall.

If it is difficult to position the first bracket, additional bracket(s) can be positioned against the strip casing. The correct number of brackets must be used and both ends of the casing must be connected with one bracket. The prongs of all brackets must be fully engaged through the notch on the casing, i.e. the prong should go in one side and out from the other side, and does not get caught inside the casing.

Plastic Pipe Penetration Seals

Retrofit installation to underside of floors

PROMASTOP® UniCollar® has been tested up to 240 minute fire resistance with various plastic pipes up to 200mm outside diameter when fixed to soffit of concrete/masonry floors (with an equal or greater fire resistance level) through the provided brackets using 20mm x 5mm steel bolt anchors, on condition that the floor is in a secure condition for holding the anchors.

Backfill all annular gaps greater than 8mm between the plastic pipe and the floor with PROMASEAL® Mortar or other commercial grade mortar mix. A suitable water resistant sealant (e.g. PROMASEAL® Supa Mastic) may be applied around the pipe on top side of the floor if a water seal is required.

If the gap is less than 8mm, apply a bead of PROMASEAL®-A Acrylic Sealant approximately 8mm deep into the gap on underside of the floor.

Retrofit installation to both sides of walls/partitions

PROMASTOP® UniCollar® has been tested up to 240 minute fire resistance with various plastic pipes up to 200mm outside diameter, depending on types and sizes of the pipes using the recommended number of the provided brackets.

For concrete/masonry walls, use the 20mm x 5mm steel bolt anchors provided. For steel/timber framed lightweight partitions, use 40mm x 10g laminating screws provided. The walls or partitions must be in a secure condition that will hold the anchors.

All annular gaps between the pipe and the walls/partitions must be minimum 2mm and filled with a bead of PROMASEAL®-A Acrylic Sealant.

Please consult Promat for details of PROMASTOP® UniCollar® retrofit installation to underside of floors and both sides of walls/partitions. For complete UL listing to these applications, please visit <http://www.ul.com>.

Other Services Penetration Seals

Retrofit installation to concrete/masonry floors

Position PROMASTOP® UniCollar® around the services and fix to the underside of the slab in the same manner as fitting for plastic pipes. Then fill any gaps inside the collar caused by the orientation of the service with PROMASEAL® Grafitex. Size of services should not exceed the inside diameter of the 100mm collar.

Retrofit installation to plasterboard walls

Position PROMASTOP® UniCollar® around the services and fix to the wall in the same manner as fitting for plastic pipes. Then fill any gaps inside the collar caused by the orientation of the service with PROMASEAL® Grafitex. Size of services should not exceed the inside diameter of the 100mm collar.

Please refer to illustrations on [page 17](#) for fixing details.

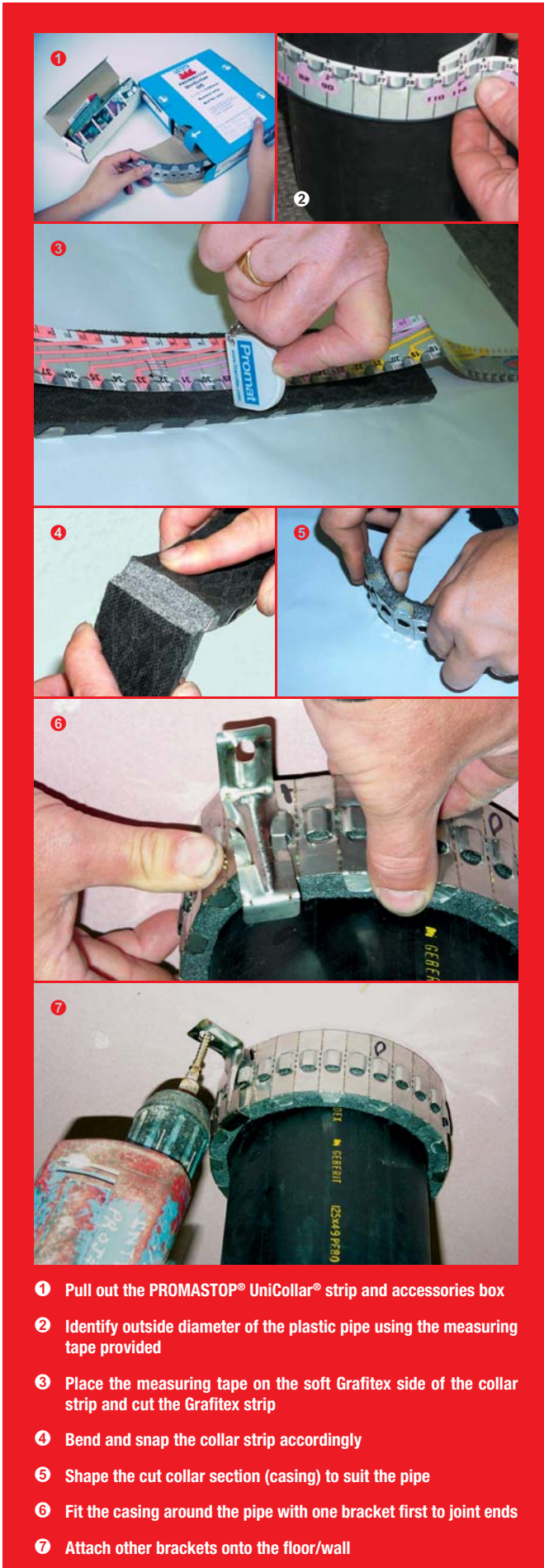

- 1 Pull out the PROMASTOP® UniCollar® strip and accessories box
- 2 Identify outside diameter of the plastic pipe using the measuring tape provided
- 3 Place the measuring tape on the soft Grafitex side of the collar strip and cut the Grafitex strip
- 4 Bend and snap the collar strip accordingly
- 5 Shape the cut collar section (casing) to suit the pipe
- 6 Fit the casing around the pipe with one bracket first to joint ends
- 7 Attach other brackets onto the floor/wall

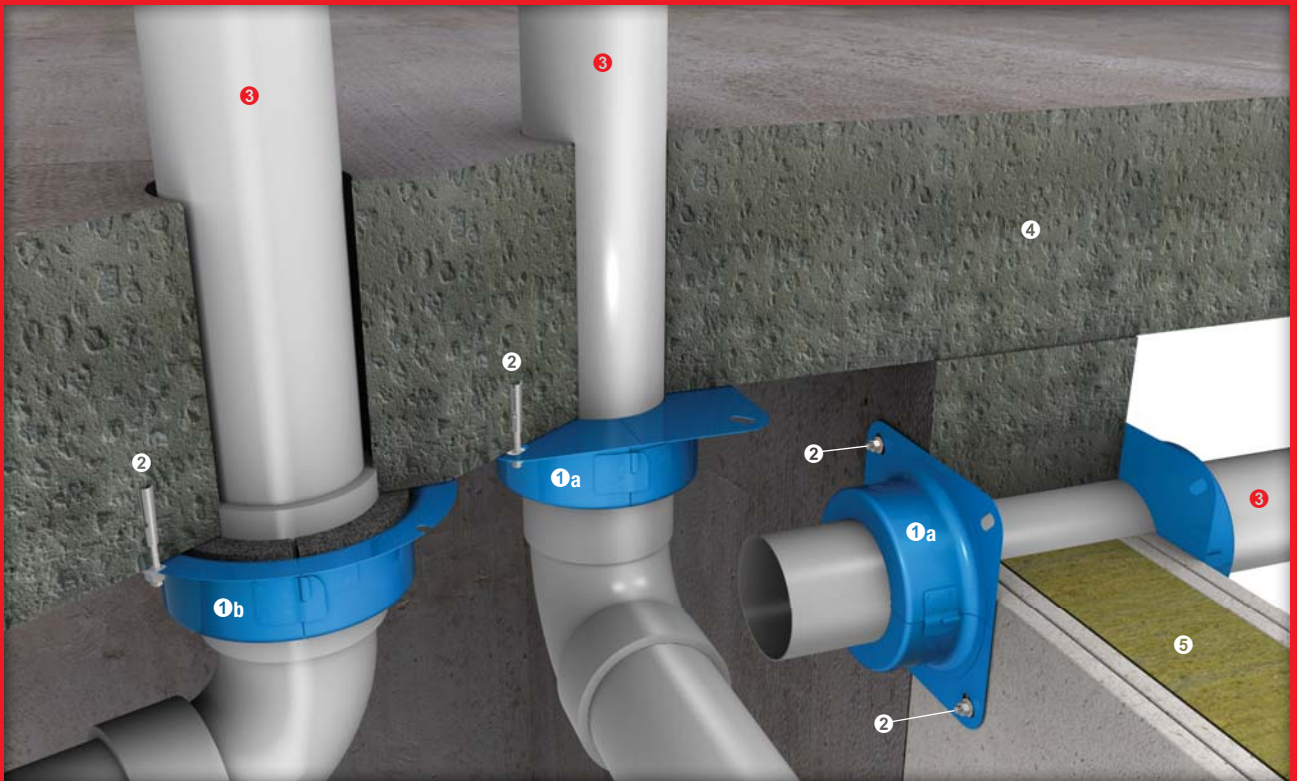

Up to -/240/240 fire resistance in accordance with the requirements of BS 476: Part 20: 1987, AS 1530: Part 4: 2005 and/or AS 4072: Part 1: 2005; insulation criteria will vary depending on type and size of plastic pipes AND the type of penetrating elements

- ①a PROMASEAL® Retrofit Collar (square base)
- ①b PROMASEAL® Retrofit Collar (circular base) for use on sockets
- ② Suitable fixing, i.e. steel bolt anchors for masonry/concrete floors and walls OR laminating screws for lightweight partitions
- ③ Various plastic piping, e.g. ABS, HDPE, uPVC
- ④ Fire resistant concrete/masonry floors or walls
- ⑤ Fire resistant steel/timber framed lightweight partitions

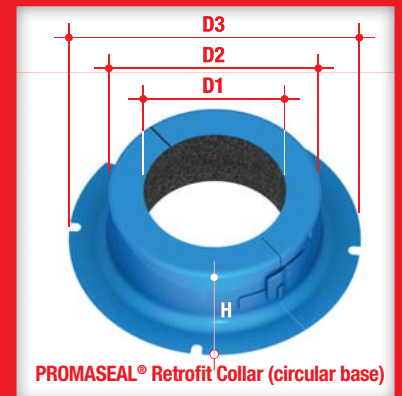
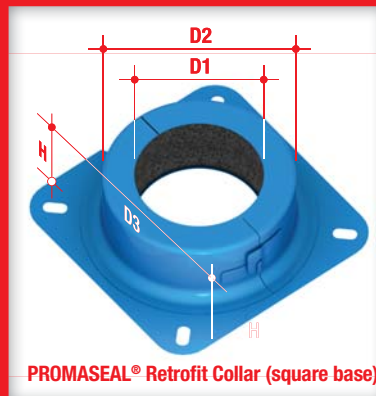

Dimensions of PROMASEAL® Retrofit Collar (square base)

Code no.		FC 40	FC 50	FC 65	FC 80	FC 100	FC 125	FC 150	FC 250	FC 300
Pipe nominal diameter	mm	40	50	65	80	100	125	150	250	300
Body	H	43	43	43	43	53	63	73	120	160
	D1	45	58	71	85	112	127	162	254	318
	D2	77	90	103	123	150	165	200	316	402
Flange	D3	112	125	138	158	185	197	235	380 Ø	466 Ø

Dimensions of PROMASEAL® Retrofit Collar (circular base)

Code no.		FCS 40	FCS 50	FCS 65	FCS 100
ABS pipe nominal diameter	mm	40	50	–	100
HDPE pipe nominal diameter	mm	50	56	75	100
uPVC nominal diameter	mm	40	50	65	100
Body	H	43	43	43	53
	D1	56	70	84	127
	D2	84	98	113	167
Flange	D3	131	145	161	214

PROMASEAL® Retrofit Collar (square base) for plastic pipes up to 162mm nominal diameter in concrete or concrete/masonry floors

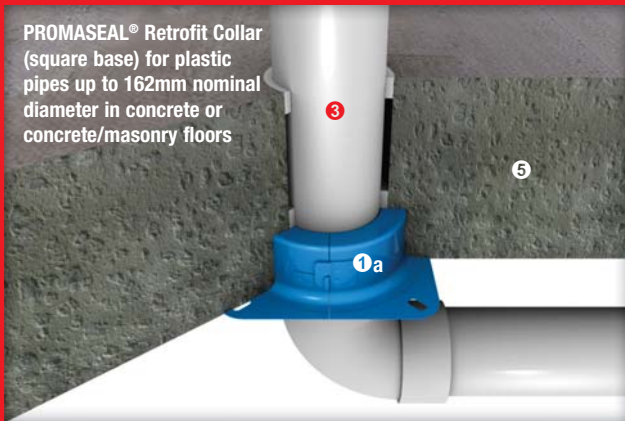

PROMASEAL® Retrofit Collar (circular base) for plastic pipes > 200mm and up to 315mm nominal diameter in concrete/masonry floors

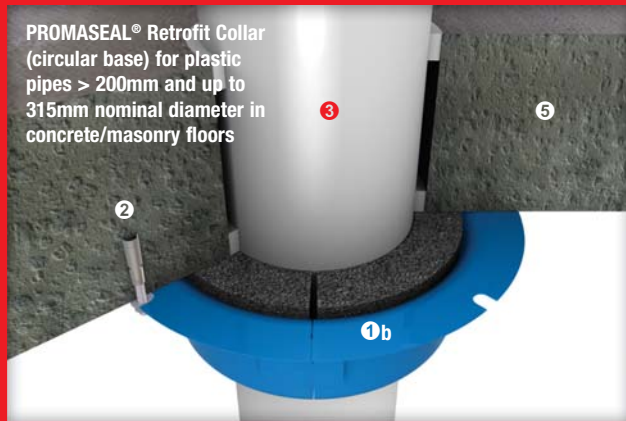

PROMASEAL® Retrofit Collar (square base) for plastic pipes up to 162mm nominal diameter in lightweight ceilings

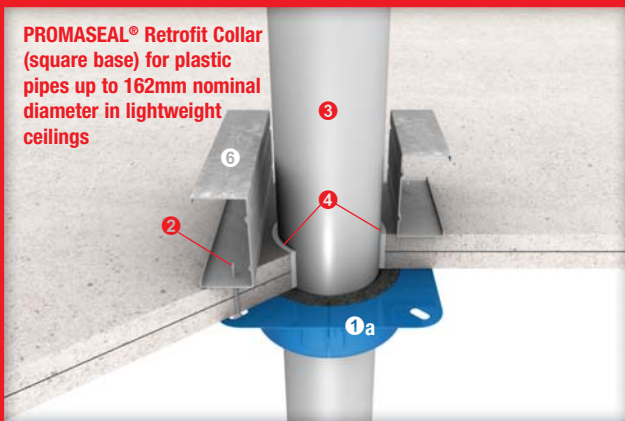

PROMASEAL® Retrofit Collar (circular base) for plastic pipes up to 162mm nominal diameter in concrete/masonry floors

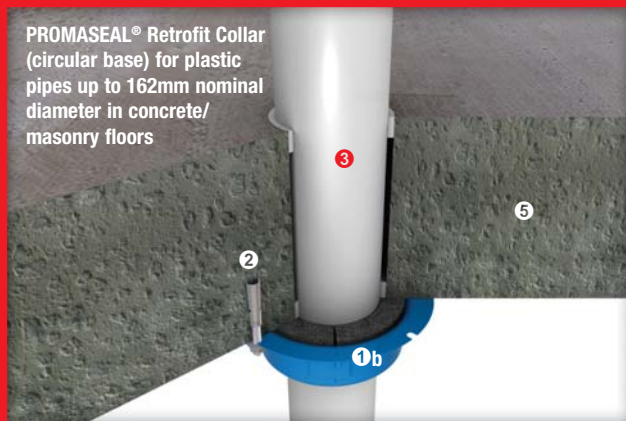

PROMASEAL® Retrofit Collar (square base) for plastic pipes up to 162mm nominal diameter in concrete/masonry floors with backfill of mortar

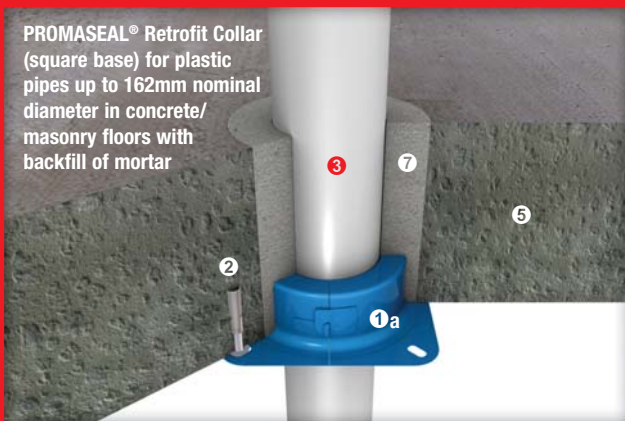

Up to -/240/240 fire resistance in accordance with the requirements of BS 476: Part 20: 1987, AS 1530: Part 4: 2005 and/or AS 4072: Part 1: 2005; insulation criteria will vary depending on type and size of plastic pipes AND the type of penetrating elements

- ①a PROMASEAL® Retrofit Collar (square base)
- ①b PROMASEAL® Retrofit Collar (circular base) for use on sockets
- ② Suitable fixing, i.e. steel bolt anchors for masonry/concrete floors and walls OR laminating screws for lightweight ceilings
- ③ Various plastic piping, e.g. ABS, HDPE, uPVC
- ④ All gaps caulked with PROMASEAL®-A Acrylic Sealant to prevent cold smoke ingress when required
- ⑤ Fire resistant concrete/masonry floors
- ⑥ Steel channel fixed at position to the fire resistant lightweight ceilings
- ⑦ PROMASEAL® Mortar

PROMASEAL® Retrofit Collar (square base)

These PROMASEAL® Retrofit Collars are multi purpose collars designed for use with concrete/masonry floors or walls, lightweight partitions and lined ceilings.

These split type collars can be retrofitted where necessary. They are available in a range of sizes to suit plastic pipes up to 315mm outside diameter. The collars have been tested up to 240 minute fire resistance in accordance with the criteria of AS 1530: Part 4: 2005 and AS 4072: Part 1: 2005 with various types and sizes of plastic pipes.

Square based PROMASEAL® Retrofit Collars above 200mm outside diameter have a circular base instead.

It should be noted that the fire resistance performance tested on some of the larger collars is limited in applications. Please consult Promat to ensure the proposed application and requisite fire resistance can be achieved.

PROMASEAL® Retrofit Collar (circular base)

These PROMASEAL® Retrofit Collars are designed to be fitted around installed pipes that pass through floors and have been tested with ABS, HDPE and uPVC pipes up to 150mm outside diameter in accordance with the criteria of BS 476: Part 20: 1987, AS 1530: Part 4: 2005 and AS 4072: Part 1: 2005.

The larger opening of the collars can accommodate the various pipes with different outside diameters. Sockets/joiners fittings are suitable for uPVC pipes up to 100mm outside diameter.

Circular based PROMASEAL® Retrofit Collars should be unclipped, placed around the pipe, re-clipped and pushed tight to the floor.

The collars have been tested up to 240 minute fire resistance in floors with ABS and uPVC pipes, up to 180 minute fire resistance in floors with different sized HDPE pipes (except 100mm which is tested up to 240 minutes), and up to 120 minute fire resistance on floors and walls.

Both square and circular based PROMASEAL® Retrofit Collars are splittable to be retrofitted or relocated when necessary.

PROMASEAL® Retrofit Collar (square base)

Plastic Pipe Penetration Seals

Retrofit installation to underside of floors

Square based PROMASEAL® Retrofit Collar (FC type) has a simple “clip and hinge” system, allowing the collar to be opened, placed or repositioned around the pipe, closed and re-clipped.

These PROMASEAL® Retrofit Collars can be used where up to 240 minute fire resistance is required with plastic pipes up to 250mm outside diameter fixed to the soffit of concrete/masonry floors (with an equal or greater fire resistance level) through the holes at the collar flange using 32mm x 6mm steel bolt anchors or bolts. The floor must be in a secure condition for holding the anchors.

For fixing plastic pipes up to 150mm outside diameter, 25mm long steel bolt anchors may be used. Plastic pipes up to 315mm outside diameter are tested up to 120 minute fire resistance. For unvented plastic pipes greater than 225mm outside diameter, the pipes are capped during the fire test on both sides of the floor either exposed or unexposed to fire.

Backfill all annular gaps greater than 12mm between the plastic pipe and the floor with PROMASEAL® Mortar or other commercial grade mortar mix. A suitable water resistant sealant (e.g. PROMASEAL® Supa Mastic) may be applied around the pipe on top side of the floor if a water seal is required.

If there is a possibility of pipe movement that might cause cracks in the mortar sealing between the plastic pipe and the floor, it is advisable to seal the pipe with PROMASEAL®-A Acrylic Sealant to prevent cold smoke ingress. However, this is not necessary for the required fire resistance performance.

Square based PROMASEAL® Retrofit Collars have been tested with various types of plastic pipes but will not accommodate fittings. This collar may also be employed to protect general building services passing through concrete/masonry floors, e.g. electrical cables, uPVC pipes and lagged copper pipes.

-/240/240 fire resistant cast-in installation of plastic pipes up to 150mm outside diameter in floors

Insert the body of the square based PROMASEAL® Retrofit Collar (FC type) into the cored hole of the floor from below, leaving the collar flange flush with the underside of the floor. The flange is fixed to soffit of the floor (with an equal or greater fire resistance level) using minimum 32mm x 6mm steel bolt anchors or 25mm x 6mm steel masonry fixings. Ensure all fixing points are used. Backfill all annular gaps on top side of the floor with PROMASEAL® Mortar or other commercial grade mortar mix.

Square based PROMASEAL® Retrofit Collars are not designed to hold plastic pipes in position. Please refer to PROMASEAL® Hi-Blu and PROMASEAL® Green Cast-in Collars on [pages 18 and 19](#) or PromaSnap® Floor Waste System on [pages 20 and 21](#) for a more efficient cast-in application.

-/240/240 fire resistant cast-in installation of plastic pipes up to 150mm outside diameter in floors

Nail the circular based PROMASEAL® Retrofit Collar (FCS type) to the formwork with the collar flange facing down or screw fixed to the metal deck formwork. Cut a section of the plastic pipe that will be used with the collar and push firmly to the collar opening until it touches the formwork. Ensure the pipe is cut level and touching the formwork all round, and is long enough to protrude above the proposed floor level.

It is wise to cover the open (top) end of the pipe to prevent concrete, masonry or other unwanted waste materials from entering. Always ensure the pipe is fixed in such a way that it remains true to the vertical axis during and after the concrete pour.

Retrofit installation to concrete/masonry walls

Square based PROMASEAL® Retrofit Collars have been tested up to 120 minute fire resistance with various types of plastic pipes up to 100mm outside diameter in concrete/masonry walls with minimum 96mm thickness. The collars are attached to either or both sides of the walls exposed to fire.

Fix the collar to the wall through the holes at the collar flange using 50mm long steel bolt anchors.

Backfill all annular gaps between the plastic pipe and the wall with PROMASEAL® Mortar, other commercial grade mortar mix or PROMASEAL® AN Acrylic Sealant.

Square based PROMASEAL® Retrofit Collars have also been tested up to 180 minute fire resistance with HDPE and uPVC pipes of 315mm outside diameter fixed to both sides of the wall. This application is achievable for unvented pipes greater than 250mm outside diameter.

Fix the collar to the wall through the holes at the collar flange using 50mm long steel bolt anchors.

Retrofit installation to lightweight partitions

Square based PROMASEAL® Retrofit Collars are not usually retrofitted to steel/timber framed partitions but have been tested to some applications as follows:

- Up to 120 minute fire resistance with uPVC pipes up to 100mm outside diameter fixed to either or both sides of the partition using 10g x 40mm laminating screws.
- Up to 180 minute fire resistance with HDPE and uPVC pipes 315mm outside diameter fixed to both sides of the partition.

Please refer to illustration on [page 13](#) for fixing details.

Fix the collar to the wall through the holes at the collar flange using 50mm self-drilling coach bolts and screwed into the noggins and studs.

Please refer to PROMASEAL® Wall Collar on [page 16](#) for a more efficient retrofit application.

Retrofit installation to ceilings

Square based PROMASEAL® Retrofit Collars have been tested up to 120 minute fire resistance with various types of plastic pipes up to 150mm outside diameter screw fixed to the trimmed framing of the ceiling (with an equal or greater fire resistance level) through the holes in the collar flange.

All annular gaps between the plastic pipe and the ceiling board must be no greater than 15mm and filled with PROMASEAL®-A Acrylic Sealant to the full depth of the board. Please consult Promat for specific requirements for various ceiling systems.

PROMASEAL® Retrofit Collar (circular base)

Plastic Pipe Penetration Seals

Retrofit installation to underside of floors

Circular based PROMASEAL® Collars (FCS) have been tested on ABS, HDPE and uPVC pipes up to 150mm outside diameter in concrete/masonry floors (with an equal or greater fire resistance level) with and without a pipe fitting at position. These collars are specifically designed for installing readily fixed plastic pipes to accommodate fitting of the pipe through the collar.

The large opening of the collars can accommodate ABS or HDPE pipes with different outside diameters and some imported pipe sizes.

Fix the collar to the floor through all four slots at the collar flange using minimum 20mm x 5mm steel bolt anchors (e.g. Redi Drive).

If the pipes are passing cored holes of a floor that do not have to be backfilled with mortar, it is necessary to seal all annular gaps between the pipe and the floor with a bead of PROMASEAL®-A Acrylic Sealant approximately 10mm deep into the gap on underside of the floor. If the annular gap is greater than 8mm it must be backfilled with mortar.

Other Services Penetration Seals

Retrofit installation to concrete/masonry floors (or plasterboard walls)

Position either square or circular base PROMASEAL® Retrofit Collars (FC or FCS) around the services and fix to the underside of the slab (or to the plasterboard wall) in the same manner as fitting for plastic pipes. Then fill any gaps inside the collar caused by the orientation of the service with PROMASEAL® Graftex. Size of services should not exceed the inside diameter of the 100mm collar. Please refer to illustrations on [page 17](#) for fixing details.

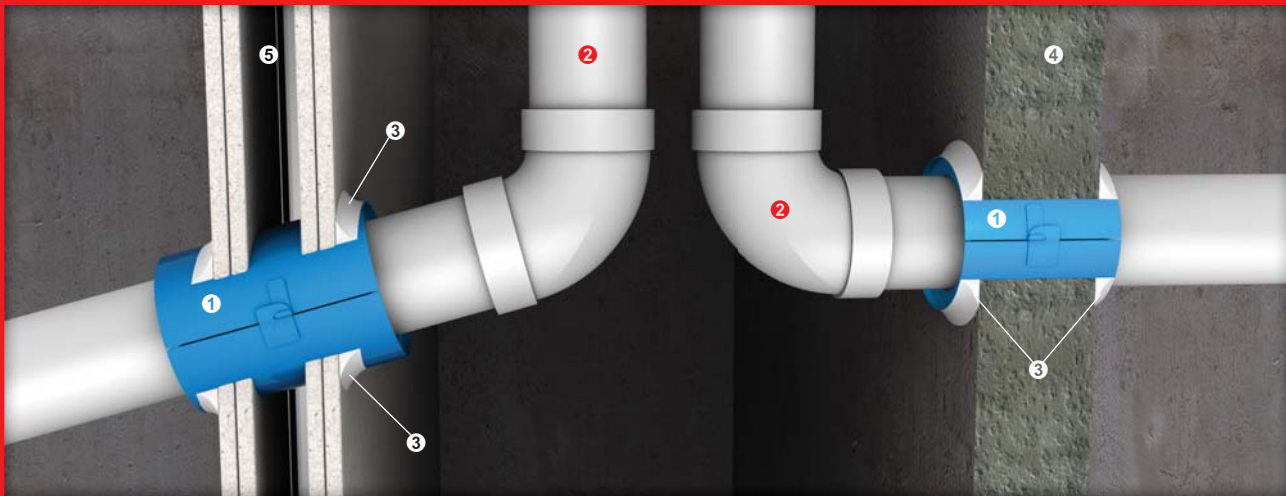

Up to -/120/120 fire resistance in accordance with the requirements of BS 476: Part 20: 1987, AS 1530: Part 4: 2005 and AS 4072: Part 1: 2005; insulation criteria will vary depending on type and size of plastic pipes AND the type of penetrating elements

- ❶ PROMASEAL® Wall Collar
- ❷ Various plastic piping, e.g. HDPE, uPVC
- ❸ All gaps caulked with PROMASEAL®-A Acrylic Sealant to achieve the required fire resistance performance
- ❹ Fire resistant concrete/masonry walls
- ❺ Fire resistant steel/timber framed lightweight partitions
- ❻ Hebel and three layers of 16mm thick plasterboard wall

Dimensions

Code no.		FCW 40	FCW 50	
Pipe nominal diameter		mm	40	50
Body	H	mm	120	120
	D1	mm	80*	90*
	D2	mm	47	60

Code no.		FCW 65	FCW 100	FCW 150	
Pipe nominal diameter		mm	65	100	150
Body	H	mm	120	120	120
	D1	mm	107*	153*	203*
	D2	mm	75	116	164

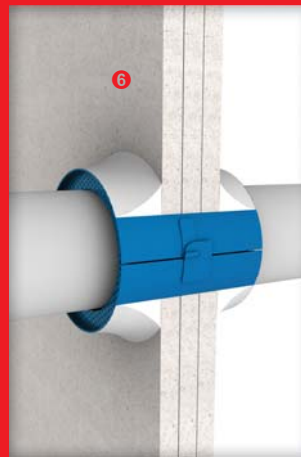

* Additional allowance of 3mm for clip

PROMASEAL® Wall Collar is designed for insertion into wall elements made of calcium silicate, plasterboard, concrete or masonry. The collar has been tested up to 120 minute fire resistance with HDPE, PPR or uPVC pipes and general building services up to 162mm outside diameter through these wall elements (with an equal or greater fire resistance level) in accordance with the criteria of BS 476: Part 20: 1987, AS 1530: Part 4: 2005 and AS 4072: Part 1: 2005.

Similar to PROMASEAL® Retrofit Collar, this is a split type collar for retrofit where necessary.

Plastic Pipe Penetration Seals

Retrofit installation to lightweight partitions (or plasterboard walls)

Locate the collar in a central position on the partition/wall. All annular gaps between the collar and the partition/wall must be no greater than 20mm and filled with PROMASEAL®-A Acrylic Sealant to a minimum depth of 32mm. If the gap is greater than 20mm, reduce it with the same materials used to build the wall/partition or backfill with PROMASEAL® Mortar.

If there is a possibility of pipe movement that might cause cracks in the mortar sealing between the plastic pipe and the floor, it is advisable to seal the pipe with PROMASEAL®-A Acrylic Sealant to prevent cold smoke ingress. However, this is not necessary for the required fire resistance performance.

Do not obstruct the perforated mesh at the ends of the collar when sealing any gaps.

Maximum thickness of the partition/wall is 128mm. For greater thickness, two collars are recommended to ensure outer face of the collar is embedded no more than 14mm measured from the partition/wall surface. It is permissible for the collar body to extend beyond surface of the wall.

Minimum thicknesses of the partition/wall using single collar on plastic pipes up to 110mm and 162mm outside diameter are 48mm and 57mm respectively.

If the partition/wall is thinner than 128mm, PROMASEAL®-A Acrylic Sealant may need to be applied to the section of collar that extends from the partition/wall in order to maintain 120 minutes insulation.

PROMASEAL® Wall Collar can be positioned at an angle providing the exposure is the similar to the original test. Please consult Promat for details of the application requirements.

Other Services Penetration Seals

Retrofit installation to plasterboard walls

Position PROMASEAL® Wall Collar around the services within the wall in the same manner as for plastic pipes. Then fill any gaps inside the collar caused by the orientation of the service with PROMASEAL® Graftex. Size of services should not exceed the inside diameter of the 100mm collar. Please refer to illustration on page 17 for fixing details.

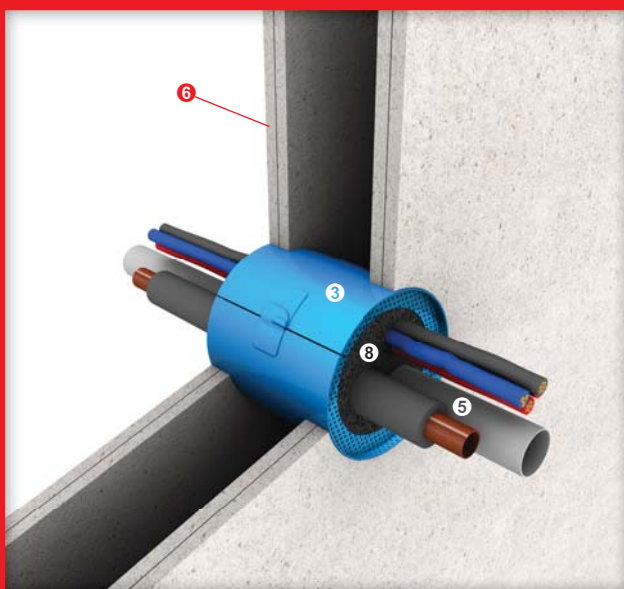
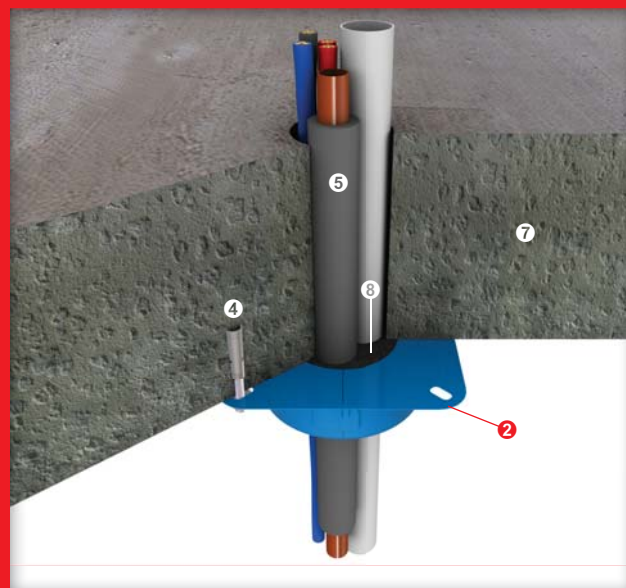
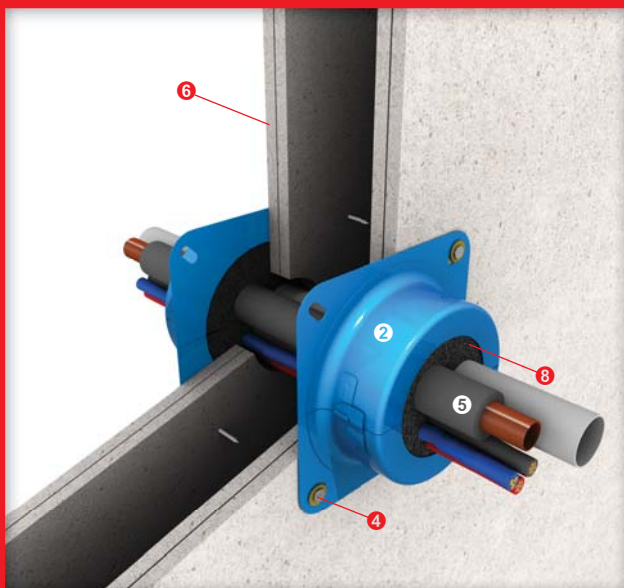
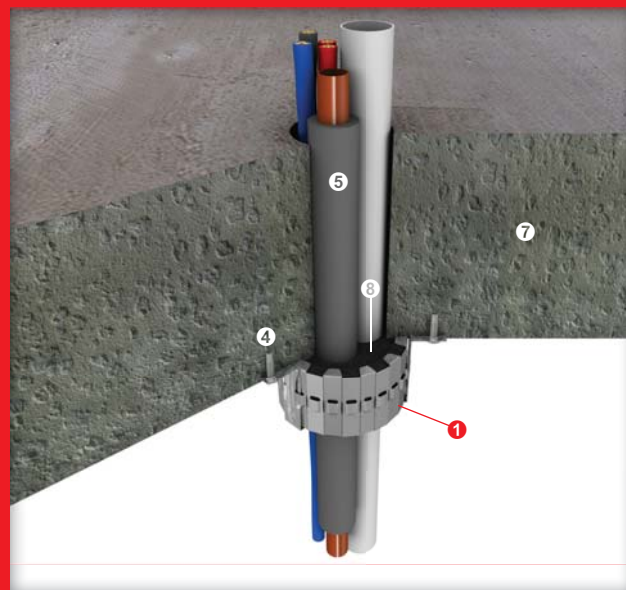
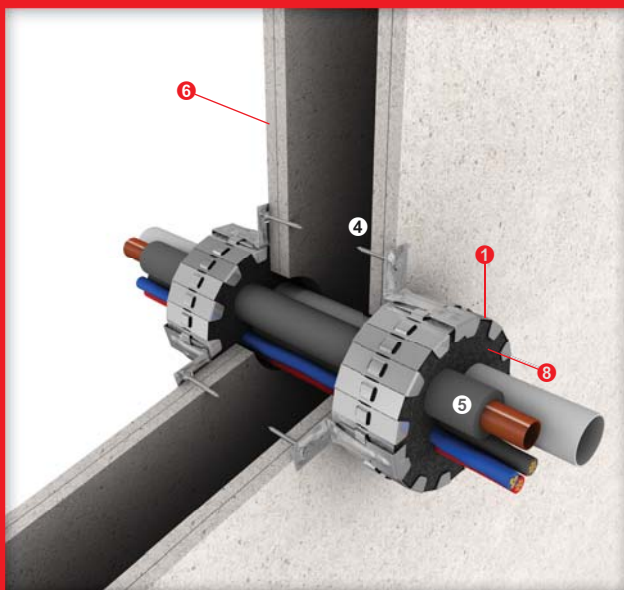

Up to -/120/120 fire resistance in accordance with the requirements of BS 476: Part 20: 1987, AS 1530: Part 4: 2005 and/or AS 4072: Part 1: 2005; insulation criteria will vary depending on type and size of building services AND the type of penetrating elements

- ① PROMASTOP® UniCollar®*
- ② PROMASEAL® Retrofit Collar (square or circular base)*
- ③ PROMASEAL® Wall Collar*
- ④ Suitable fixing, i.e. laminating screws for lightweight partitions OR steel bolt anchors for masonry/concrete floors
- ⑤ Various building services, e.g. electrical cables, plastic (uPVC or PEX) pipes and/or insulated copper pipes
- ⑥ Fire resistance lightweight partitions
- ⑦ Fire resistant concrete/masonry floors
- ⑧ All gaps between collars and services filled with PROMASEAL® Graftex

*Nominal size of ①, ② or ③ is maximum 100mm

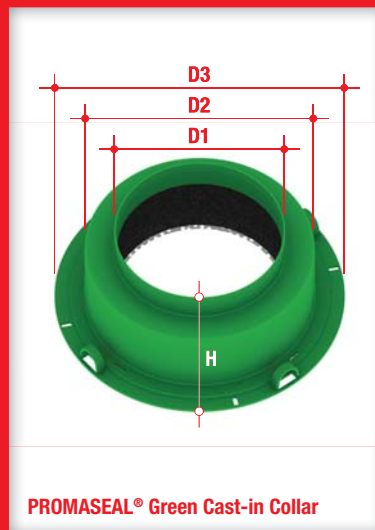
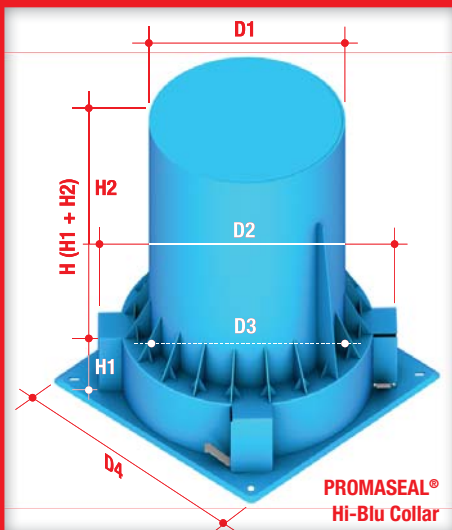
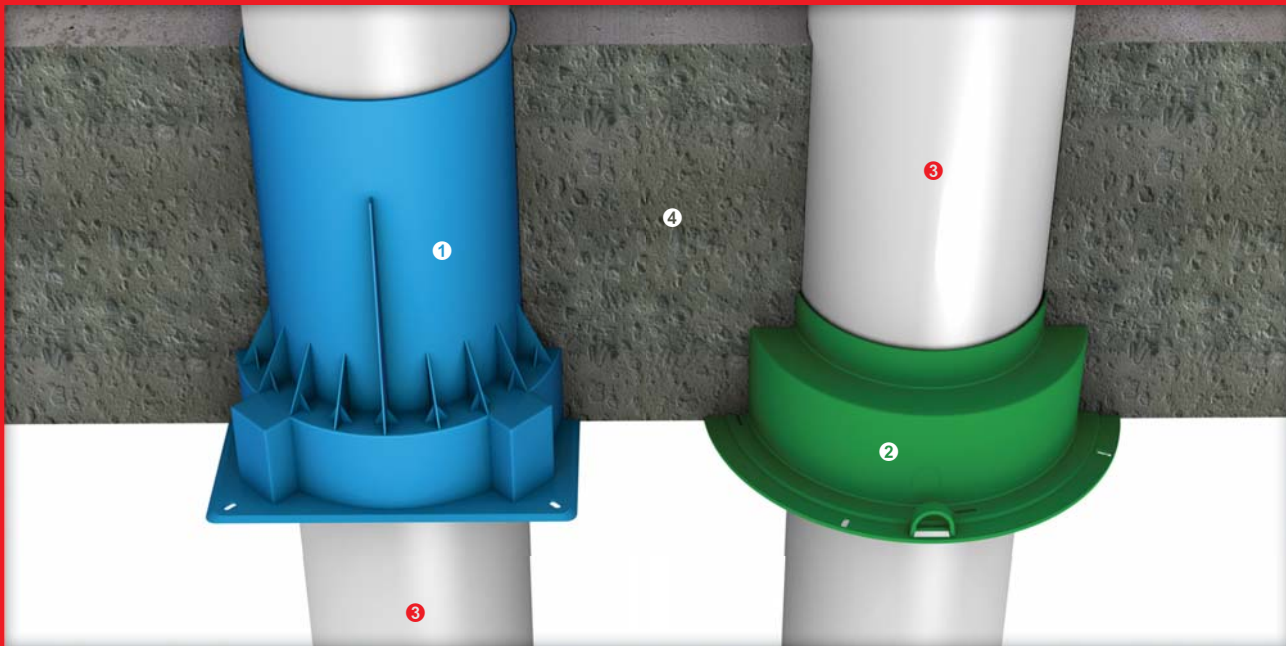

Up to -/240/240 fire resistance in accordance with the requirements of AS 1530: Part 4: 2005 and AS 4072: Part 1: 2005; insulation criteria will vary depending on type and size of plastic pipes AND the type of penetrating elements

- ① PROMASEAL® Hi-Blu Collar
- ② PROMASEAL® Green Cast-in Collar
- ③ Various plastic piping, e.g. HDPE, uPVC
- ④ Fire resistant concrete/ masonry floors

Dimensions of PROMASEAL® Hi-Blu Collar

Code no.		Hi-Blu 65	Hi-Blu 100	Hi-Blu 150
Body	H mm	250	250	250
	H1 mm	45	57	57
	H2 mm	205	193	193
	D1 mm	95	140	194
	D2 mm	132	178	232
Flange	D3 mm	97	142	197
	D4 mm	154	198	253

Dimensions of PROMASEAL® Green Cast-in Collar

Code no.		Green 40	Green 50	Green 65	Green 80	Green 100	
uPVC pipe nominal diameter		mm	40	50	65	80	100
Body	H mm	49 + 30*	49 + 30*	49 + 20*	60 + 20*	60 + 20*	
	D1 mm	43	56	69	83	110	
	D2 mm	115	115	115	163	163	
Flange	D3 mm	160	160	160	210	210	

* Additional height of upright pipe grip

NOTE: Both PROMASEAL® Hi-Blu Collar and PROMASEAL® Green Cast-in Collar are NOT to be used in floor wastes



Pictures above and on the right

Pre and post installations of PROMASEAL® Hi-Blu Collars (the residential units of Mawson Lakes, SA) and PROMASEAL® Green Cast-in Collars (Adelaide Towers and 40 Walker St Rhodes, NSW) for stackwork in Australia.

PROMASEAL® Hi-Blu Collar

PROMASEAL® Hi-Blu Collar is designed for fixing to formwork prior to pouring of concrete. The collar has been tested up to 240 minute fire resistance in stack applications with various types of plastic pipes through concrete/masonry floors (with an equal or greater fire resistance level) in accordance with the criteria of AS 1530: Part 4: 2005 and AS 4072: Part 1: 2005, with insulation up to 180 minutes on PPR pipes and up to 240 minutes on both HDPE and uPVC pipes.

PROMASEAL® Hi-Blu Collar is available in THREE (3) sizes:

- 1) Small, for pipes up to nominal 65mm diameter;
- 2) Medium, for pipes between the diameter of 65mm and 100mm; and
- 3) Large, for pipes of nominal 150mm diameter.

Please consult Promat before installing the collar to ensure types and sizes of intended plastic pipes are compatible with the particular type and size of collar.

Cast-in installation to concrete/masonry floors

PROMASEAL® Hi-Blu Collar accommodates the plastic pipe fitting within the soffit of the floor and thus helps to save space.

See above photographs. Place the collar on formwork. Fix the collar into position through slots at the flange using 20mm long 3mm flat head clouts/nails. Do not skew the nails.

Once concrete is poured and cured, cut off the extension above the slab, then place pipe work through.

It should be noted that if the pipe must be pushed in from the top side, the rubber seal will be forced downwards. Lift the pipe slightly to ensure that the rubber seal projects upwards. All annular gaps between the collar and the pipe must be backfilled with concrete, PROMASEAL® Mortar or other commercial grade mortar mix.

PROMASEAL® Green Cast-in Collar

PROMASEAL® Green Cast-in Collar is designed for fixing to formwork prior to pouring of the floor concrete. The collar has been tested up

to 240 minute fire resistance in stack applications with various types of plastic pipes through concrete/masonry floors (with an equal or greater fire resistance level) in accordance with AS 1530: Part 4: 2005 and AS 4072: Part 1: 2005, with insulation up to 180 minutes on uPVC pipes and up to 240 minutes on selected HDPE pipes.

Sizes of PROMASEAL® Green Cast-in Collar range from 43mm to 110mm outside diameter.

PROMASEAL® Green Cast-in Collar will close uPVC pipes and the fittings in the event of fire.

For floors using lost formwork or less than 120mm thick, please consult Promat for the application of PROMASEAL® Green Cast-in Collar.

Cast-in installation to concrete/masonry floors

PROMASEAL® Green Cast-in Collar accommodates the uPVC pipe fitting within the soffit of the floor and thus helps to save space.

Place the collar on formwork. Fix the collar into position through slots at the flange using 20mm long 3mm flat head clouts/nails. Do not skew the nails.

Insert a pipe section through the collar so that the end of the pipe sits flat on the formwork and ensure the top side of the pipe is higher than the finished floor depth. Ensure the pipe section must remain true, vertically in place, during the concrete pour and immediately afterwards.

After the formwork is stripped, knock the short section of the pipe (used for casting before) out of the collar and replace with the complete pipe section.

Both PROMASEAL® Hi-Blu and PROMASEAL® Green Cast-in Collars have been extensively tested on permanent formwork decks, e.g. "KingFlor". These are profiled steel decks with an uneven soffit that requires specific application requirements. Please consult Promat for details.



PrumaSnap® Floor Waste System is manufactured entirely from recycled and recyclable materials. The product is qualified by the WaterMark™ Certification Scheme.

Actual colour may vary from illustrations.

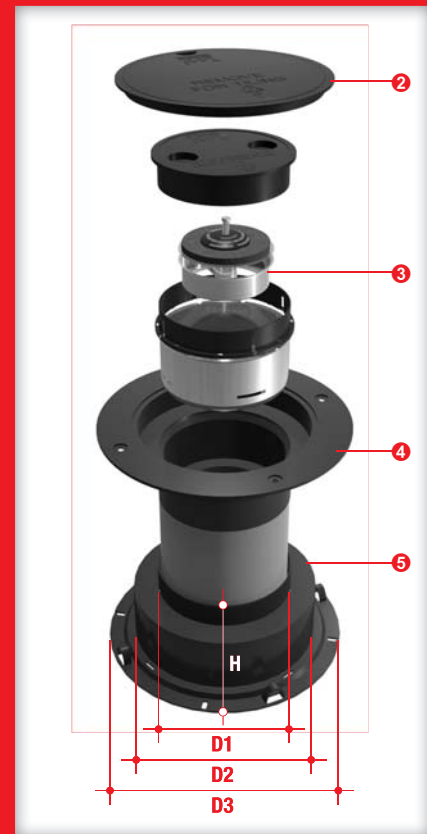

Up to -/120/120 fire resistance in accordance with the requirements of AS 1530: Part 4 and AS 4072: Part 1: 2005; insulation criteria will vary depending on type and size of plastic pipes AND the type of penetrating elements

- ❶ PromaSnap® Floor Waste System
- ❷ Outer cap for keeping concrete, water and rubbish out of pipe work during construction, positioned flush with the finished/tiled floor to eliminate any tripped hazards and enable the floor floated off and free from any obstacles.
- ❸ Central core with cap, adjustable to the correct screed height of the finished/tiled floor
- ❹ Puddle flange set at the exact height of the finished/tiled floor
- ❺ PROMASEAL® PipeSeal for holding the plastic pipe to the formwork prior to pouring of the floor concrete
This product can be supplied individually in Australia but it has no fire resistance classification. Only the PPS 100 model is suitable for PromaSnap® Floor Waste System. See dimensions in table below and guide to complete models on page 23
- ❻ uPVC plastic piping
- ❼ Floor waste grate
- ❽ Fire resistant concrete/masonry floors

Code no.		PPS 100	
uPVC pipe nominal diameter	mm	100	
Body	H	mm	78
	D1	mm	110
	D2	mm	163
Flange	D3	mm	210

Floor wastes in wet areas are notoriously difficult for fire resistant penetration seals. The lack of a pipe stack above the floor level means that the floor waste grate offers little protection from fire and smoke once the pipe work has burnt through.

AS 4072: Part 1: 2005 demands that the fire resistance test of floor waste must be conducted on pipe work that is identical to the installed configuration.

PromatSnap® Floor Waste System has been tested up to 120 minute fire resistance with uPVC pipes and fittings in accordance with the criteria of AS 1530: Part 4: 2005 and AS 4072: Part 1: 2005 for an effective, simple, waterproof floor waste solution to leveling the screed of the floor tiling with the water flow.

The concrete/masonry floors must have an equal or greater fire resistance than 120 minutes.

PromatSnap® Floor Waste System consists of a built-in puddle flange with waterproofing membrane. The puddle flange can be recessed into the floor with rised lip eliminated. The weep holes in the base of the flange allow moisture under the floor tiles to drain away.

Also built-in is a closer device that will shut at the first sign of fire.

If, for any reason, the pipe or the closer device need to be cleaned, simply remove the closer device through the opening of the floor waste grate. After cleaning, replace the closer device by pushing downwards until it clicks firmly into the opening. Replacement units of the closer device are available upon request from Promat.

Cast-in installation to concrete/masonry floors



1) Nail or screw fix the PROMASEAL® PipeSeal to the formwork through the notches in the flange of the PipeSeal.



4) Standard waterproofing membrane procedures should be adopted before a screed is applied. The outer cap should be removed and the waterproofing membrane should be applied according to the manufacturer's recommendation. The outer and inner caps are recyclable. Promat recommends that they be returned, if possible, for recycle purposes.



2) Cut a nominal 100mm diameter piece of the uPVC pipe. The pipe should be 75mm or less if the finished depth of the floor will be greater than 125mm. To ensure the puddle flange is level with floor depth, it may be prudent to cut the pipe slightly less than 75mm. The pipe should be cut level at both ends and as close as possible to but no more than the required length for finishing.

For floor depth finished in less than 125mm, reduce the spigot length of the puddle flange that connects to the pipe.



5) The membrane should be applied over the outer face/exposed side of the fixed puddle flange. Apply standard concrete adhesive if required. Lift the cap of the central core and adjust it to the required height level of the finished/tiled floor. This core can be raised to 25mm above the floor level.



3) Glue the pipe to the spigot of the puddle flange using standard uPVC adhesive. Ensure the spigot is fully inserted into the pipe and pushed firmly into the opening of the PROMASEAL® PipeSeal until it sits squarely on the formwork. Adjust the puddle flange to floor depth. After pouring of the floor concrete, leave the outer cap in place to prevent ingress of rubble or water.

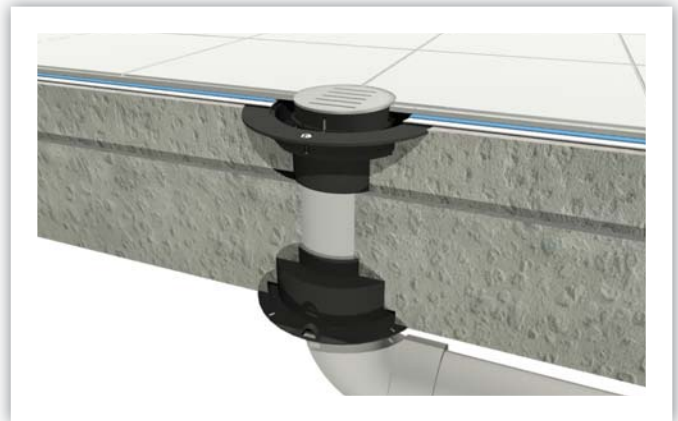

6) Remove the inner cap after tiling and floor waste grate are installed. If additional height is required, apply a grate with longer sides that will raise it to required level. Apply the cement/sand screed to the floor to level its required depth.

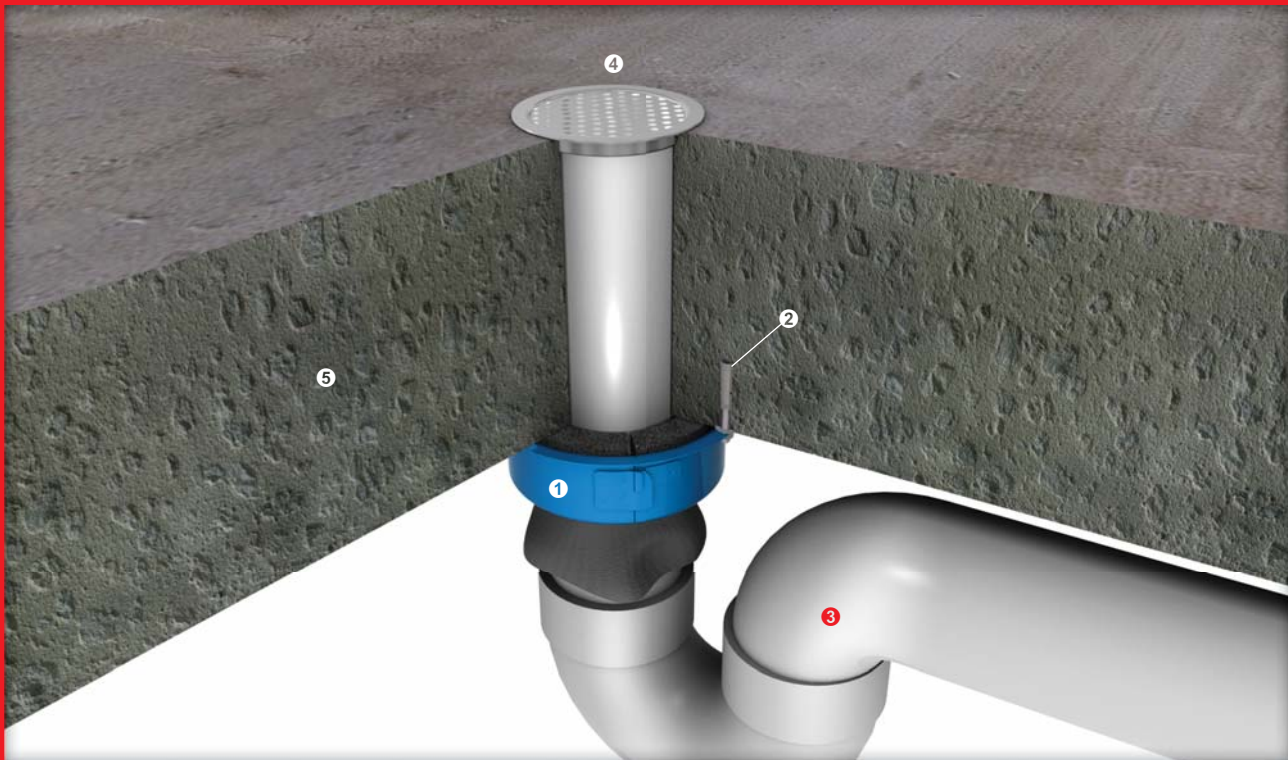

Up to -/240/180 fire resistance in accordance with the requirements of AS 1530: Part 4: 2005 and AS 4072: Part 1: 2005; insulation criteria will vary depending on type and size of plastic pipes AND the type of penetrating elements

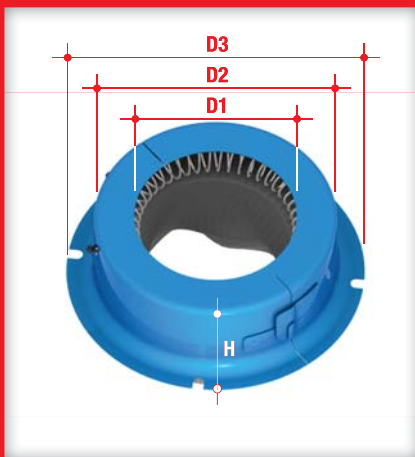

- ❶ PROMASEAL® Retrofit Floor Waste Collar
- ❷ Suitable steel bolt anchors
- ❸ uPVC plastic piping
- ❹ Floor waste grate
- ❺ Fire resistant concrete/masonry floors

Dimensions

Code no.			FWR 100
uPVC pipe nominal diameter	mm	50 / 80 / 100	
Body	H	mm	70
	D1	mm	110
	D2	mm	167
Flange	D3	mm	209

PROMASEAL® Retrofit Floor Waste Collars are surface mounted collars manufactured with Promat intumescent technology. The collars are designed to accommodate pipe fittings within its body and provide fire resistant penetration seals for floor wastes in wet areas.

PROMASEAL® Retrofit Floor Waste Collars have been tested up to 240 minute fire resistance with uPVC pipes through concrete/masonry floors (with an equal or greater fire resistance level) in accordance with the criteria of AS 1530: Part 4: 2005 and AS 4072: Part 1: 2005 for floor waste traps up 50mm, 80mm and 100mm nominal diameters.

Where the uPVC pipes used for floor waste stack systems are fire resistant type, use PROMASEAL® Retrofit Floor Waste Collars as tested to above standards to maintain the fire resistance of the element. All works are to be certified in an approved manner.

Installation

Retrofit installation to concrete/masonry floors

Unclip the joint of a PROMASEAL® Retrofit Floor Waste Collar and pull the collar apart into two sections. Place them around the uPVC pipe, close and re-clip.

Fix the collar to the floor through all four slots at the collar flange using minimum 35mm long 6.5mm steel bolt anchors. The cloth skirt provided inside the collar must be pulled down to its full extent.

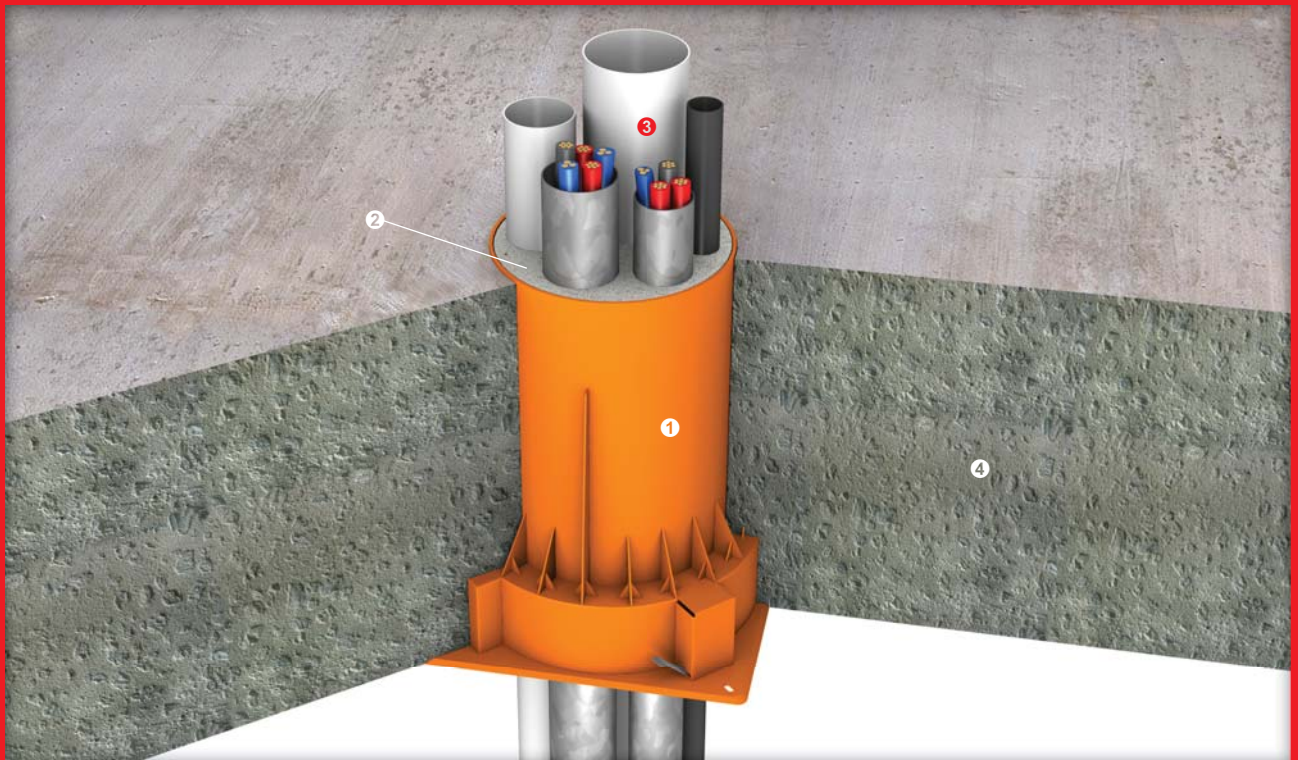

Up to -/180/120 fire resistance in accordance with the requirements of AS 1530: Part 4: 2005 and AS 4072: Part 1: 2005; insulation criteria will vary depending type and size of building services AND the type of penetrating elements

- ① PROMASEAL® Services Seal Collar
- ② PROMASEAL® Mortar
- ③ Various building services, e.g. electrical cables
- ④ Fire resistance concrete/masonry floors

Dimensions

Code no.		PSS 100
Maximum diameter of services		mm 120*
Body	H	mm 250
	D1	mm 140
Flange	D2	mm 198

* Allowance of 10mm for backfill around services

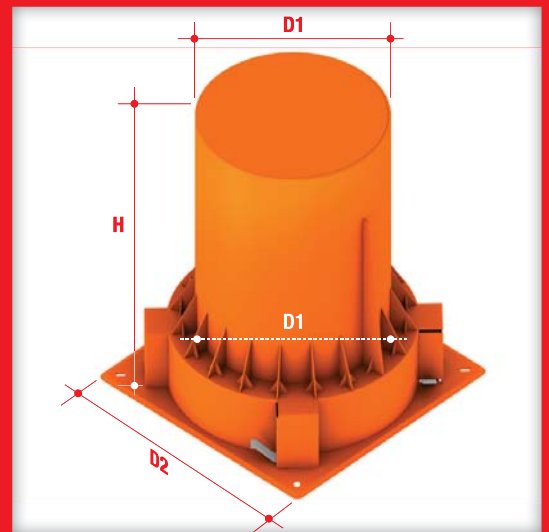

PROMASEAL® Services Seal Collars are designed for attaching to formwork prior to pouring of the floor concrete. The collars have been tested with various building services (including electrical cables, lagged plastic pipes and/or combination of these within a single unit) through concrete/masonry floors in accordance with the criteria of AS 1530: Part 4: 2005 and AS 4072: Part 1: 2005 for:

- Up to -/120/120 fire resistance within a minimum 120mm thick floor (with an equal or greater fire resistance level), and
- Up to -/180/120 fire resistance within a minimum 150mm thick floor (with an equal or greater fire resistance level)

Please check with local authorities to ensure that the particular services etc are included in the scope of approvals for the application of PROMASEAL® Services Seal Collars.

Installation

Cast-in installation to concrete/masonry floors

Accurately position the PROMASEAL® Services Seal Collar on

formwork and secure it firmly with nails through all four holes of the collar flange, before pouring floor concrete.

Before installing the services, trim off any ends of the collar that extends above the floor and replace the cap at the floor level to prevent debris from entering the collar.

After installing the services, backfill the collar with PROMASEAL® Mortar up to a level with the floor. Ensure the mortar mix does not reach below the level of the intumescent inside the collar to avoid interfering with its closing/sealing function. This can be easily achieved by slightly lifting the services after they are installed to ensure the intumescent projects upwards.

If the services are tightly packed and not practical for backfill with mortar, use PROMASEAL®-A Acrylic Sealant or trowel grade PROMASEAL® Grafitex instead and inject it to the maximum depth with and around the services as well as above the intumescent.

PROMASEAL® Services Seal Collar leaves a neat appearance after removal of formwork and prevents the steel reinforcement from any exposure caused by coring.

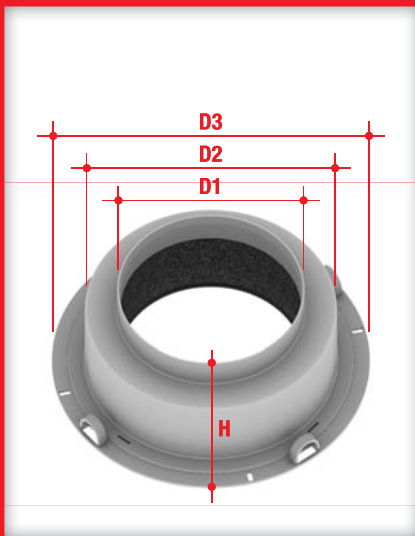

- ① Promat PipeSeal® Cast-in Collar
- ② uPVC plastic piping
- ③ Fire resistance concrete/masonry floors

Dimensions

Code no.		PPS 40	PPS 50	PPS 65	PPS 80	PPS 100	PPS 150
uPVC pipe outside diameter	mm	43	55	69	83	110	160
uPVC pipe nominal diameter	mm	40	50	65	80	100	170*
Body	H	mm	78	78	68	78	150
	D1	mm	43	55	69	83	110
	D2	mm	115	115	115	163	163
Flange	D3	mm	160	160	160	210	210

* Allowance of 10mm for backfill around pipes

Promat PipeSeal® Cast-in Collar is designed to be fixed to the formwork prior to pouring concrete floor slabs to provide openings in floor slabs for non fire resistant plastic pipe penetrations. The collar is available in FIVE (5) sizes to accommodate pipes with an outside diameter of 43mm, 55mm, 69mm, 83mm or 110mm.

Installation

After the formwork has been stripped, the piece of pipe may be removed from the collar leaving an opening in the floor ready for the installation of the service.

Promat PipeSeal® Cast-in Collars leave a neat appearance after stripping and prevents the exposure of the steel reinforcement caused by coring.

Promat PipeSeal® Cast-in are designed to provide openings in cast slabs. The product will not provide a seal in the event of a fire and has no fire resistance level classification.

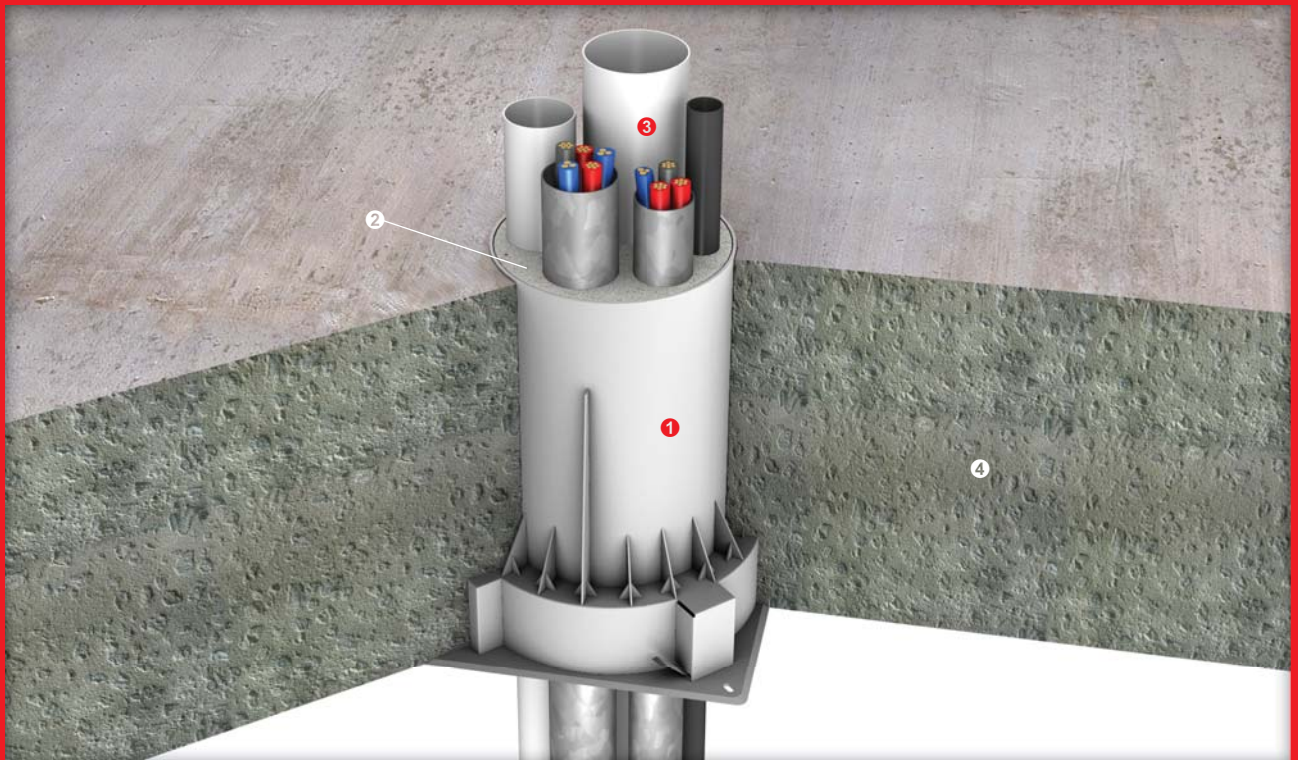

- ❶ Promat MultiSeal® Cast-in Collar
- ❷ PROMASEAL® Mortar
- ❸ Various building services, e.g. electrical cables
- ❹ Fire resistance concrete/masonry floors

Dimensions

Code no.		MSS	MSM	MSL
Maximum diameter of services	mm	75*	120*	170
Body	H mm	250	250	250
	D1 mm	95	140	190
Flange	D2 mm	155	198	253

* Allowance of 10mm for backfill around services

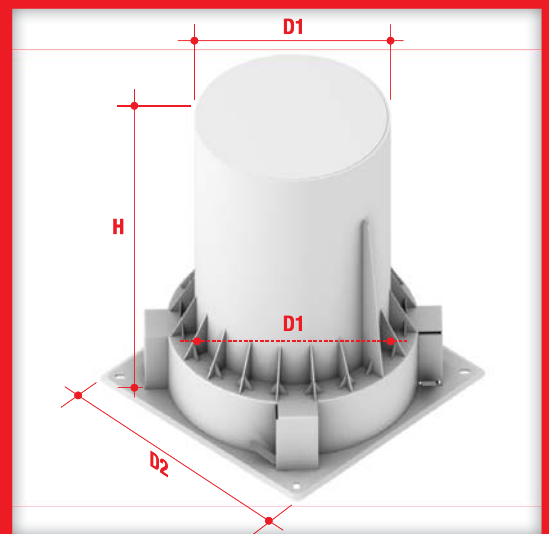

Promat MultiSeal® Cast-in Collar is designed to be fixed to the formwork prior to pouring concrete floor slabs to provide openings in floor slabs for multiple service penetrations.

Promat MultiSeal® Cast-in Collar is available in THREE (3) sizes:

- 1) Small, for services up to nominal 75mm diameter;
- 2) Medium, for services up to nominal 120mm diameter; and
- 3) Large, for services up to nominal 170mm diameter.

Installation

Promat MultiSeal® Cast-in Collars leave a neat appearance after stripping and prevents the exposure of the steel reinforcement caused by coring. Trim off any of the part that extends above the floor slab.

After the installation of the services, backfill the collar with a mortar mix to the full height of the floor slab.

Promat MultiSeal® Cast-in collars are designed to provide openings in cast slabs. The product will not provide a seal in the event of a fire and has no fire resistance level classification.



It is important to be aware of some basic facts regarding the application of sealant within control joints before attempting any installation of such products.

There is considerably more to providing an effective seal at a joint than merely filling the “as constructed” gap with an impervious material. The function of the gap filler depends as much on the movement to be accommodated at the joint and on the shape of the joint as on the physical properties of the material placed within the joint. If short cuts are taken, performance more often than not will simply not match expectations.

The function of a joint is to connect adjacent components or elements of construction in such a way that the performance of the connecting joint is maintained. Therefore, the joint should preserve, across the gap between the adjoining components, the properties of the elements—such as thermal insulation, acoustic insulation, weather exclusion (if in an external location), resistance to fire etc — to a degree sufficient for the structure as a whole to function as intended.

In addition, the jointing method must allow for inherent inaccuracies between the elements, e.g. inaccuracies in the setting out process and positioning, for some dimensional adjustments during construction as well as tolerances within the components of the elements of construction themselves. Where necessary, some allowance for building movement should also be made.

PROMASEAL®-A Acrylic Sealant has no difficulty meeting thermal and acoustic insulation requirements. Many test results confirm its fire resistance capabilities. However, the question of joint movement needs further consideration, particularly if the product is to be suitable for use in a ductile steel framed high rise structure.

Building movement from not only thermal and moisture effects but also wind and seismic forces is one of many factors which must be considered by engineers. Joint size, therefore, is likely to be a difficult decision to make in many instances if detailed investigations are not made.

On the other hand, joint size and shape may often be predetermined by the profile of prefabricated purpose-made components or products.

Where this is not the case, however, the shape of the joint should be designed to take into account factors such as the magnitude and direction of anticipated movement in adjoining components, type of stress expected, the need for seals to maintain integrity, accessibility for inspection, maintenance and replacement if necessary. It should be noted, however, that joint design all too often is based on lowest cost rather than best cost/performance considerations.

Joint Types

There are TWO (2) types of sealant joints to be considered, the butt joint and the lap joint:

1 Butt Joints

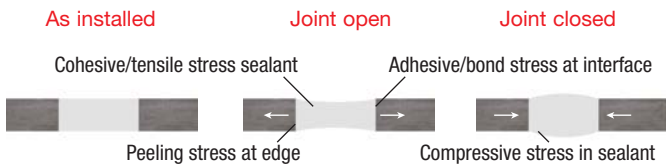

2 Lap Joints

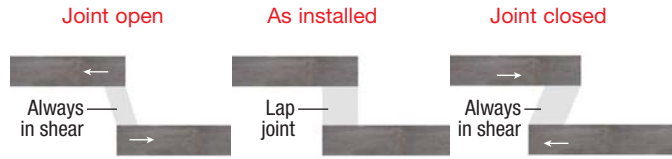

In most cases, the butt joint, which is the most common method, is subjected to the greatest stress and movement, particularly from wind or seismic forces. The modulus of elasticity of a butt joint under ideal conditions is three times the strength of a joint in shear conditions. Consequently, the stress in the sealant is considerably greater. The speed of movement and sealant recovery properties are also important considerations.

Materials

Sealants fall into the following categories:

- Plastic, accommodating movement but showing little or no recovery after deformation;
- Plasto-elastic, showing limited recovery;
- Elasto-plastic, showing some elastic recovery but subject to a degree of stress relaxation under deformation; and
- Elastic, recovers almost completely after deformation.

1 Joint Configuration Of Butt Joints

Joint dimensions are a great importance. Calculations of expected movement will indicate the size of joint required. Minimum joint width to allow for effective application of a sealant is recognised as 5mm. Maximum widths are determined by the sealant type, the application method and the manufacturer’s specification.

Experience shows preferred width to depth ratios should be:

- Plastic 3:1 to 1:1
- Plasto-elastic 2:1 to 1:1
- Elasto-plastic 1:1 to 1:2
- Elastic 1:2

2 Joint Depth To Width Ratio

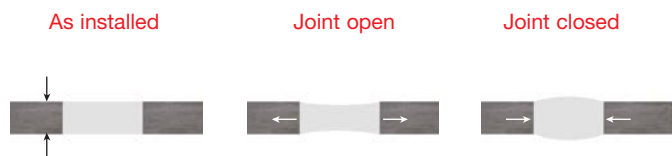

3 Stress Relaxation

In simple terms, with stress relaxation in a sealant joint, due to the characteristics of plastic behaviour, some set, flow and stress relocation occurs. The extent of its effect depends on the properties of the particular materials used and ambient conditions such as temperature, repetition and rapidity of the cycles of stress and reversal and duration of deformation at constant strain. Plastic behaviour by and large returns it to original shape by flow, and is thus only acceptable for sealant use in joints with small and relatively slow movements.



Shape Factor

Gun applied sealants are solid or semi solid at service temperatures. They alter their shape but not their volume as the joint opens and closes. The strains in the sealant and hence the adhesive and cohesive stresses developed are a critical function of the shape of the sealant.

Backing materials are used to achieve the desired shape in sealant joints. The most important requirement for a backing material is that it should not adhere to the sealant. If it should do so, a bond breaker must be incorporated so that the sealant is free to assume the desired shape.

Secondary benefits of using a backing material are that it supports the sealant and enables good adhesion to be gained with the joint's side interfaces, as well as controlling the applied depth of the material. A number of readily compressible materials such as closed and open cell foamed polyethylene are used for this purpose.

If a bond breaker is necessary, an appropriate width of polyethylene film in strip form is ideal. Bond breakers are required where the sealant is expected to adhere to three sides of the joint. For example, at the junction of a partition wall and floor slab where the sealant can adhere to the slab on the top, the partition lining board on the bottom and the steel wall track on the back.

Closed cell foams are used if there is the possibility of water being present and perhaps being absorbed through the rod to the sealant. This will affect the curing rate of the sealant.

Therefore, particular care must be taken to avoid the mixing of water and sealant.

1 Function Of Bond Breaker Material

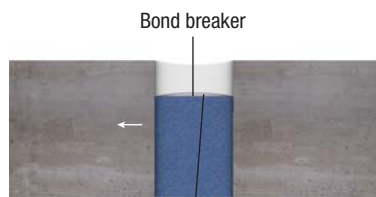

Sealant can now freely assume parabolic surface on the bottom as well as the top

2 Function Of Backup

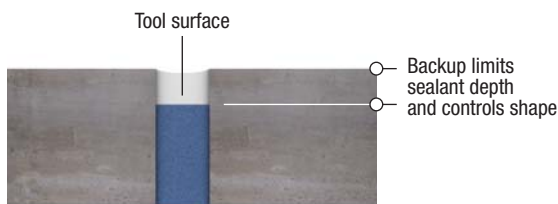

Additional benefit is to support sealant and to prevent sag

3 Current Practice



Preformed round rod/tube (partly compressed)

General Notes On Installation Of Sealants

The most appropriate techniques for applying a joint sealant depends on types of material, widths, shapes (e.g. vertical, horizontal, overhead etc) and accessibility of the joints and whether it is a small or large job.

The specification for the work should state how the sealant is to be installed and any special features required in the construction or preparation of the joint to receive the sealant.

The most appropriate time to install sealant in the field, if the construction schedule permits, is on dry days when the temperature is close to the annual mean. However, a satisfactory job can, and usually must be done in less than ideal conditions, provided the effects of this are not overlooked and reasonable allowance for compensatory factors are built into the work plan.

Restrictions on joint width and temperature at the time of sealant installation should be shown on plans or specified. In the absence of these, installations at an air temperature above 35°C or below 5°C should generally be avoided. The surface temperature of the two elements forming the joint may also need to be taken into consideration.

With sealant, it is important to abrade/roughen/scuff the exposed face to ensure intimate contact with the faces/sides of the elements either side of the joint, to remove any trapped air or voids, to consolidate the material and to provide a neat and uniform appearance.

1 Performance

Poor workmanship is probably the greatest single cause of premature failure of sealant in building joints. Failure can usually be attributed to one or more of the following:

- The designed joint was an impossible width, shape etc for successful seal, yet a contractor still went ahead with the installation;
- Service conditions resulted in greater joint movement than those either anticipated or allowed for;
- Inappropriate sealant for the particular conditions, often selected on the basis of false economy;
- New sealants are occasionally over promoted, particularly in their initial life cycle, and used before a thorough assessment of their real life (as opposed to test life) limitations are realised;
- Poor workmanship occurred when constructing the joint, in preparation and/or during installation of sealant.

2 Conclusions

The cost of providing properly sealed joints using the best available sealant for the intended purpose, carefully installed in joints and subject to correct types, shapes, sizes and locations, is usually only a very tiny fraction of the total cost of a building.

In the final analysis, there is no justification for poor sealing practices when the very integrity and service life of the building may be at stake.

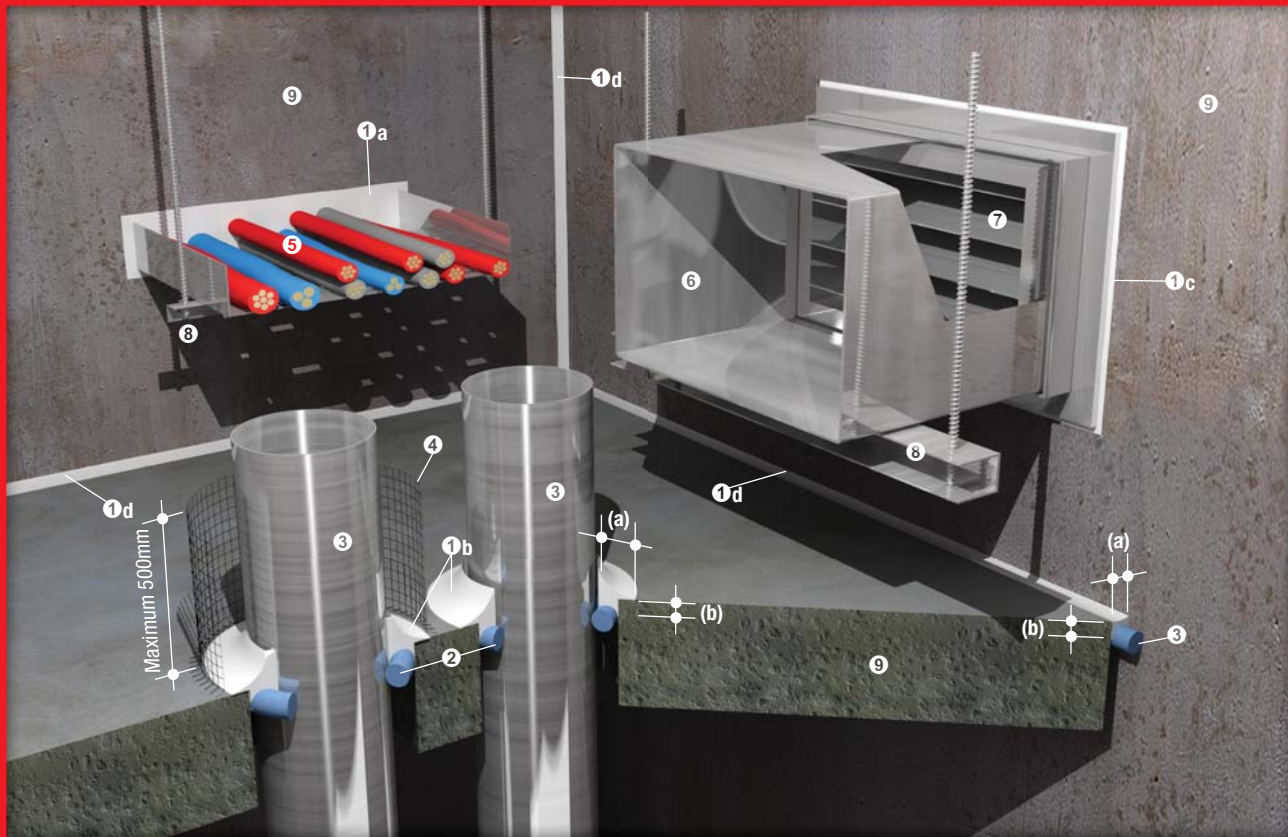

Control joint seals in junctions between a lightweight partition and a concrete/masonry wall

Up to -/240/240 fire resistance in accordance with the requirements of BS 476: Part 20: 1987 and/or AS 1530: Part 4: 2005, depending on applications and types of penetrating elements

- 1a PROMASEAL®-A Acrylic Sealant for penetration seals of electrical cables and cable trays (up to -/180/- fire resistance, or up to -/120/120 fire resistance if PROMASEAL® Wrap or mesh guard is applied) in walls and partitions
- 1b PROMASEAL®-A Acrylic Sealant for penetration seals of cored hole-fixed non combustible metal pipes (up to -/120/- fire resistance, or up to -/120/120 fire resistance if PROMASEAL® Wrap or mesh guard is applied*) or cast-in non combustible metal pipes (up to -/240/- fire resistance, or up to -/120/120 fire resistance likewise*) in floors and walls
- 1c PROMASEAL®-A Acrylic Sealant for penetration seals of steel ventilation duct (up to -/240/- fire resistance) in walls and partitions
- 1d PROMASEAL®-A Acrylic Sealant for control joint seals in floors, walls and partitions; fire resistance in accordance with specifications in the table below
- 2 Polyethylene backing rods
- 3 Non combustible metal pipes up to 150mm nominal diameter
- 4 Steel wire mesh to maintain distance from combustible materials where insulation criteria is required (please consult Promat for details)
- 5 Electrical cables supported with cable tray or steel trunking
- 6 Steel ventilation duct
- 7 Fire damper
- 8 Steel angles and/or rod hangers, supported and fixed within 300mm measured from the walls
- 9 Fire resistant concrete/masonry floors or walls
- 10 Fire resistant steel/timber framed lightweight partitions

Width to depth ratio in control joint seals

Fire resistance performance / thickness of penetrating elements		Up to -/120/120 for minimum 120mm thick elements					Up to -/180/180 for minimum 150mm thick elements					Up to -/240/240 for minimum 170mm thick elements				
		10	20	30	40	50	10	20	30	40	50	10	20	30	40	50
Gap width (a)	mm	10	20	30	40	50	10	20	30	40	50	10	20	30	40	50
Fire side (b)	mm	10	10	15	-	-	10	10	15	-	-	20	20	20	-	-
Non fire side	mm	10	10	-	-	-	10	10	-	-	-	10*	10*	-	-	-
Both sides	mm	10	10	15	20	20	10	10	15	20	20	10	10	15	20	20

* Up to -/240/180 fire resistance

PROMASEAL®-A Acrylic Sealant is a water based acrylic sealant. The advantages of water based sealant is in making post installation and/or site clean up very easy. It is also environmentally friendly. If installed correctly and once cured, PROMASEAL®-A Acrylic Sealant should not crack and it can be simply over painted. It has good resistance to water characteristics and some movement capabilities.

There are, however, some key points to remember:

- PROMASEAL®-A Acrylic Sealant is not recommended as an external water seal.
- It should not be used where continuous water immersion is likely.
- It should not be used in areas where the atmosphere is continually wet or damp, e.g. bathrooms.
- It is not recommended for use in high movement joints. In fact, PROMASEAL®-A Acrylic Sealant should not be employed in joints that require more than ±15% movement.

General Application Considerations

PROMASEAL®-A Acrylic Sealant will adhere to a wide range of surfaces. All common foam backer rods are suitable as bond breakers. Surfaces do not need priming if dust free. If in doubt, apply the diluted (by adding 50% water) PROMASEAL®-A Acrylic Sealant to the surfaces by brush.

It is essential that the correct width to depth ratio of PROMASEAL®-A Acrylic Sealant is maintained in control joint seals (see table on page 28).

In order to cure correctly, PROMASEAL®-A Acrylic Sealant must not be subjected to high humidity or moisture during the curing period. Please refer to **Exterior And Fire Resistant Seals In Control Joints** below.

PROMASEAL®-A Acrylic Sealant should not be applied if the air temperature is below 5°C or above 35°C. If the prevailing ambient temperature is outside this range it may effect the curing of the sealant; the surface temperature of the separating elements must also be taken into consideration.

Maintenance

Painting

Once properly cured, PROMASEAL®-A Acrylic Sealant may be finished and is compatible with most paints. Please confirm the compatibility of the paint and sealant by conducting a small scale test sample before use.

Clean Up

PROMASEAL®-A Acrylic Sealant is water based and can thus be cleaned up with water. Please check the latest local regulations for the correct disposal of waste product and waste cleaning water.

Acoustic Applications

PROMASEAL®-A Acrylic Sealant has been approved for use with certain acoustic ratings. Please refer to page 30 for the STC value performance levels of the sealant in control joint seals.

Exterior And Fire Resistant Seals In Control Joints

If PROMASEAL®-A Acrylic Sealant has to be used externally, it must be applied in strict accordance with the manufacturer's instructions. The surfaces to which the sealant is to be applied must be dust free to ensure correct adhesion. If there is any doubt about the adhesion of the sealant to the surfaces, prime first by brushing diluted sealant (add approximately 50% water) on to the surfaces.

Backer rod should be inserted into the joint at a position which allows the correct depth of sealant to be applied. It is important to follow the chart provided by the manufacturer for this depth. Do not install the sealant to a depth greater than recommended.

The PROMASEAL® AN Acrylic Sealant must be protected from the elements (e.g. water, freezing etc) until it is fully cured. The curing period will vary depending upon prevailing weather conditions and the size (width or depth) of the joint. Dampness from surrounding building elements can lead to prolonged curing periods.

For maximum long term aesthetic properties, the sealant should have a film preservative (paint) applied over. This coating must be maintained. For exterior use however, such a coating is often not acceptable or even practical. For example, consider maintaining the paint on a multi storey building.

For these and other reasons, Promat does not recommend the use of this product for exterior application. Promat and its official associates will not issue warranties for such exterior applications.

Limitations

It has been demonstrated that occasionally water based sealants develop cracks during the curing cycle for no apparent reason. Conditions during application and immediately thereafter usually contribute to such failures. Acrylic sealant needs to cure at temperatures above 8°C in order to form a uniform seal. Current theory suggests that very porous substrates such as blockwork, combined with low temperatures or high humidity are the prime contributors to failure. This phenomenon may interfere with acoustic performance characteristics but will not affect the fire resisting properties unless the cracking is particularly severe and cracks are pronounced.

After application, the PROMASEAL®-A Acrylic Sealant starts to cure by forming a skin where it is in contact with air. Ordinarily, curing occurs at a rate of about 2mm every 24 hours at 25°C and 5% relative humidity (RH). At low temperatures, however, the curing rate is reduced considerably. When a poorly formed thin skin is tensioned due to the sealant shrinking quickly, the skin can tear away from one edge or split down the middle. The deeper the joint, the greater the likelihood of failure as the skin stretches further in forming a concave finish.

The conventional remedy is to repair the joint by refinishing the affected area with more sealant. It is usually not necessary to cut out and remove the sealant, unless the gap size renders the repair job too difficult.

Promat has a policy of continual improvement through innovative research and development. For confirmation on accuracy of test results, please consult Promat.

Usage For Floors Or Walls Of An Equivalent Fire Resistance Level

To calculate the required PROMASEAL®-A Acrylic Sealant for an application in floors or walls of an equal or greater fire resistance level:

Multiply the joint width (mm) x Joint depth (mm) x Joint length (m)

Divide this result by the required volume of the container, i.e. 300ml, 600ml or 10000ml. See table below for guidance.

Joint size (mm)	Depth of sealant (mm)	Metres per 300mm cartridge	Metres per 600mm foil	Metres per 10 litre pail
10	10	3.0	6.0	100.0
20	10	1.5	3.0	50.0
30	15	0.66	1.33	22.2
40	20	0.38	0.75	12.5
50	25	0.24	0.48	8.0

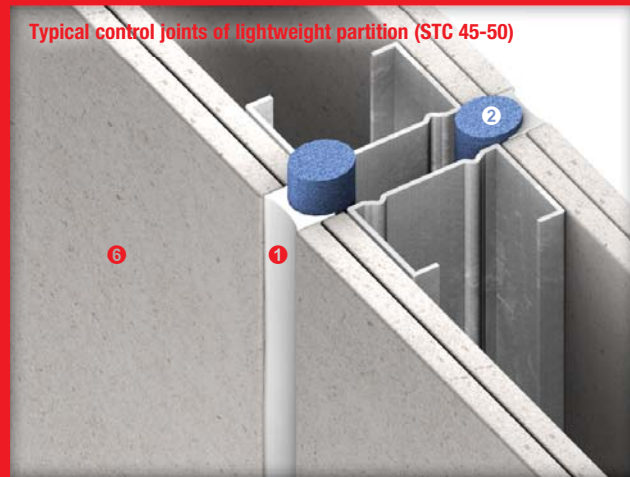
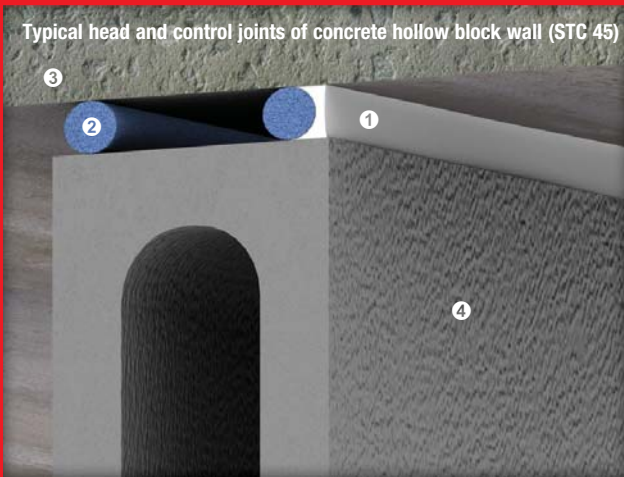
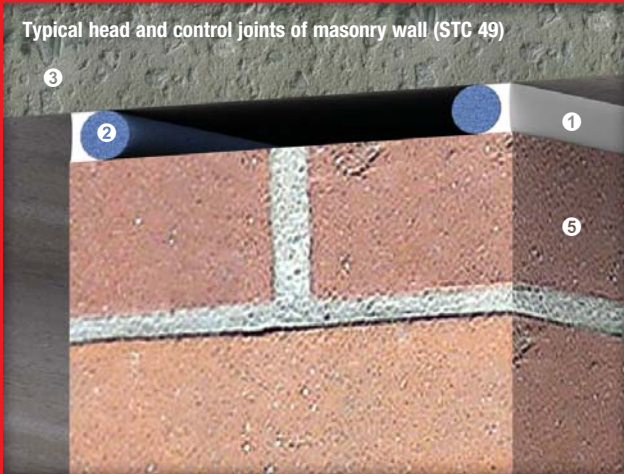

Up to -/240/240 fire resistance in accordance with the requirements of BS 476: Part 20: 1987 and/or AS 1530: Part 4: 2005, depending on applications and types of penetrating elements

- ① PROMASEAL®-A Acrylic Sealant for control joint seals in floors, walls and partitions; STC value performance in accordance with table below
- ② Polyethylene backing rods
- ③ Fire resistant concrete floors
- ④ Fire resistant concrete hollow block walls
- ⑤ Fire resistant masonry walls
- ⑥ Fire resistant steel/timber framed lightweight partitions

STC value performance levels of PROMASEAL®-A Acrylic Sealant in control joints

Typical head and control joints of masonry wall	Typical head and control joints of concrete hollow block wall	Typical head joints of lightweight partition	Typical head joints of lightweight partition with infill	Typical head and control joints of lightweight partition	Typical control joints of lightweight partition	Typical control joints of lightweight partition with infill
Wall STC 49	Wall STC 45	Wall STC 45	Wall STC 50	Wall STC 39	Wall STC 45	Wall STC 50
Joint STC 51	Joint STC 33	Joint STC 47	Joint STC 47	Joint STC 43	Joint STC 41	Joint STC 41
System STC 49	System STC 45	System STC 45	System STC 50	System STC 39	System STC 45	System STC 50

PROMASEAL®-A Acrylic Sealant is a water based acrylic sealant. The advantages of water based sealant is in making post installation and/or site clean up very easy. It is also environmentally friendly. If installed correctly and once cured, PROMASEAL®-A Acrylic Sealant should not crack and it can be simply over painted. It has good resistance to water characteristics and some movement capabilities.

There are, however, some key points to remember:

- PROMASEAL®-A Acrylic Sealant is not recommended as an external water seal.
- It should not be used where continuous water immersion is likely.
- It should not be used in areas where the atmosphere is continually wet or damp, e.g. bathrooms.
- It is not recommended for use in high movement joints. In fact, PROMASEAL®-A Acrylic Sealant should not be employed in joints that require more than $\pm 15\%$ movement.

General Application Considerations

PROMASEAL®-A Acrylic Sealant will adhere to a wide range of surfaces. All common foam backer rods are suitable as bond breakers. Surfaces do not need priming if dust free. If in doubt, apply the diluted (by adding 50% water) PROMASEAL®-A Acrylic Sealant to the surfaces by brush.

PROMASEAL®-A Acrylic Sealant should not be applied if air temperature is below 5°C or above 35°C. If the prevailing ambient temperature is outside this range it may effect the curing of the sealant; the surface temperature of the separating elements must also be taken into consideration.

As a general rule, PROMASEAL®-A Acrylic Sealant when applied around such services as pipes and cables, should not be applied in a gap width greater than 20mm to 25mm. It must also be recognised that sealant has performance limitations and should not be regarded as a "cure all" gap filling solution.

Please refer to [page 32](#) for some typical application details. If the required application is not covered in those details, please consult Promat.

Most applications will have PROMASEAL®-A Acrylic Sealant applied in a symmetrical fashion, e.g. to both sides of the wall and the unexposed top side of the floor. PROMASEAL®-A Acrylic Sealant can extend up to 30mm onto the wall or floor surface and up to 100mm along the cable or pipe, away from the wall or floor.

The depth of the sealant is based upon the available fire test data. The drawings detailed on [page 32](#) show PROMASEAL®-A Acrylic Sealant applied into a gap around services to various depths. The depth can vary, e.g. between 5mm and 32mm deep, other times it may need to be the full depth of the substrate.

Please check with the details of the manufacturers' fire tests and technical data sheets to ensure the correct minimum or maximum gaps and depths of the sealant is applied.

PROMASEAL®-A Acrylic Sealant can be used in conjunction with other penetration sealing systems such as fire collars, PROMASEAL® Bulkhead Sealer System, PROMASEAL® Mortar, and PROMASEAL® Pillows.

Where insulation criteria is required for services a PROMASEAL® Wrap or mesh guard can be installed.

Wherever services penetrate barrier systems, PROMASEAL®-A Acrylic Sealant should be used in conjunction with the appropriate fire stopping system to ensure there are no small gaps which will allow smoke to penetrate the barrier. In external or wet areas the use of PROMASEAL® Supa Mastic is recommended as an alternative.

The penetration seals of PROMASEAL®-A Acrylic Sealant around floors also assists in stopping the passage of water and/or cold smoke through the floor or wall. However, for permanent water seals appropriate products should be used, e.g. silicones or polyurethanes.

PROMASEAL®-A Acrylic Sealant can also be used as an Acoustic Sealant. This is useful for architects and acoustic engineers working on areas of accommodation, e.g. hotels, offices, residential apartments etc.

PROMASEAL®-A Acrylic Sealant can only maintain the STC rating of the system, which includes the services penetrating the barrier.

Acoustic tests have not been carried out on all services. Therefore applications which require a specific acoustic performance may have to be assessed on their own merits on a case by case basis.

Exterior Penetration Seals Of General Building Services

If PROMASEAL®-A Acrylic Sealant has to be used externally, it must be applied in strict accordance with the manufacturer's instructions. The surfaces to which the sealant is to be applied must be dust free to ensure correct adhesion. If there is any doubt about the adhesion of the sealant to the surfaces, prime first by brushing diluted sealant (add approximately 50% water) on to the surfaces.

Backer rod should be inserted into the joint at a position which allows the correct depth of sealant to be applied. It is important to follow the chart provided by the manufacturer for this depth. Do not install the sealant to a depth greater than recommended.

The PROMASEAL® AN Acrylic Sealant must be protected from the elements (e.g. water, freezing etc) until it is fully cured. The curing period will vary depending upon prevailing weather conditions and the size (width or depth) of the joint. Dampness from surrounding building elements can lead to prolonged curing periods.

At 25°C and 50% humidity, PROMASEAL®-A Acrylic Sealant will cure at a rate of 2-3mm in depth in the first 24 hours and 1mm in the next 24 hours. Thus a 10mm deep joint will take eight days to fully cure, assuming these ambient conditions are continuous.

For maximum long term aesthetic properties, the sealant should have a film preservative (paint) applied over. This coating must be maintained. For exterior use however, such a coating is often not acceptable or even practical. For example, consider maintaining the paint on a multi storey building.

For these amongst other reasons, Promat does not recommend the use of this product for exterior use. Promat and its official associates will not issue warranties for such exterior applications.

PROMASEAL® Supa Mastic

PROMASEAL® Supa Mastic is a one part polyurethane based sealant suitable for external and wet area applications. Installation as well as the approvals are similar to those prescribed for PROMASEAL®-A Acrylic Sealant. Please consult Promat for more details as the approvals for this new product are increasing at all times.

Electrical cables and cable tray passing through lightweight partition

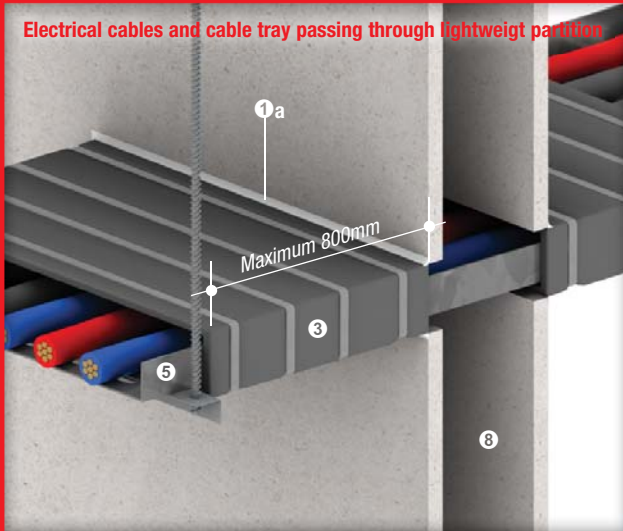

Bunch of electrical cables penetrating concrete floor

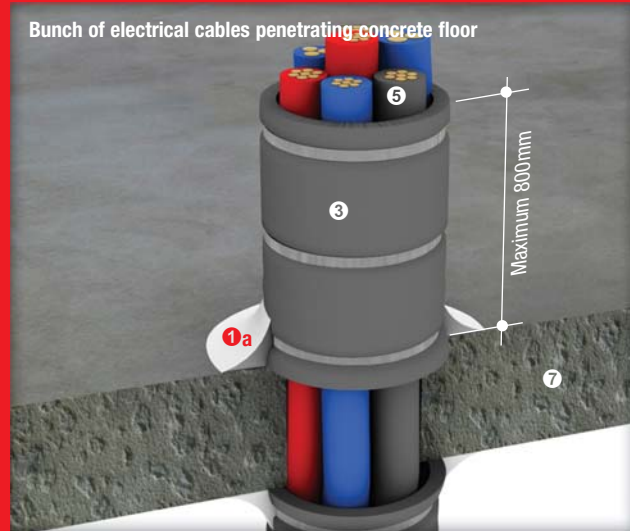

Bundle of electrical cables passing through lightweight partition

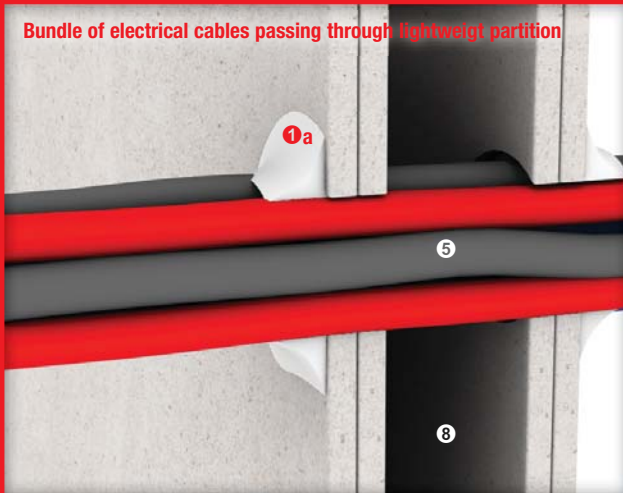

Metal pipe passing through lightweight partition

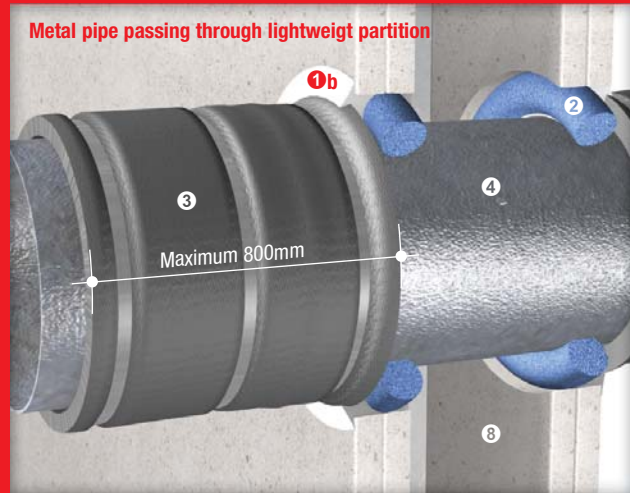

Metal pipe penetrating concrete floor

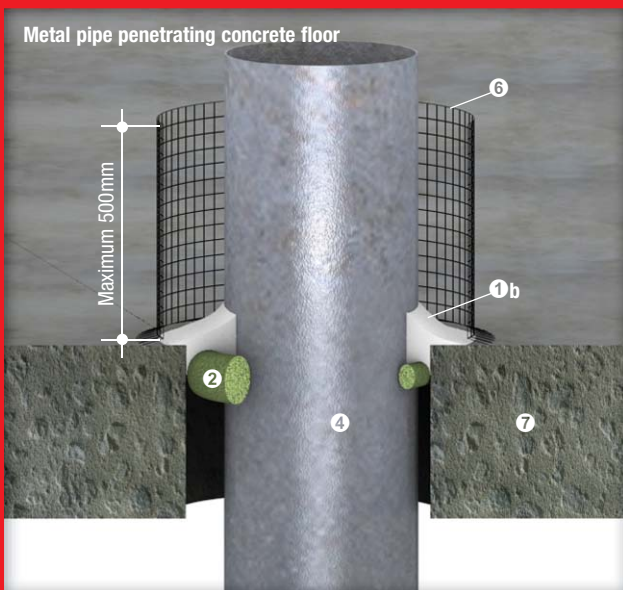

Up to -/240/- fire resistance in accordance with the requirements of BS 476: Part 20: 1987 and/or AS 1530: Part 4: 2005, depending on applications and types of penetrating elements

- ①a PROMASEAL®-A Acrylic Sealant for penetration seals of electrical cables and cable trays (up to -/180/- fire resistance) in floors and partitions
- ①b PROMASEAL®-A Acrylic Sealant for penetration seals of cored hole-fixed metal pipes (up to -/120/- fire resistance) or cast-in metal pipes (up to -/240/- fire resistance) in floors and partitions
- ② Polyethylene backing rods (or PROMASEAL® IBS™, see pages 35 and 36)
- ③ PROMASEAL® Wrap
- ④ Non combustible metal pipes* up to 150mm nominal diameter
- ⑤ Electrical cables with or without supporting cable tray/steel trunking
- ⑥ Steel wire mesh to maintain distance from combustible materials where insulation criteria is required (please consult Promat for details)
- ⑦ Fire resistant concrete floors
- ⑧ Fire resistant steel/timber framed lightweight partitions

All above penetraton sealing systems apply equally to concrete, masonry, plasterboard and dry construction materials (e.g. PROMATECT®-H, PROMATECT® 50, PROMATECT® 100 and PROMINA® 60) where the structure has a fire resistance level equal or greater than the proposed system

*Use of copper pipes instead might affect the overall fire resistance performance of the penetration seal due to the fact that copper is a high conductor of heat. Please consult Promat for application of PROMASEAL®-A Acrylic Sealant on penetration seals of copper pipes

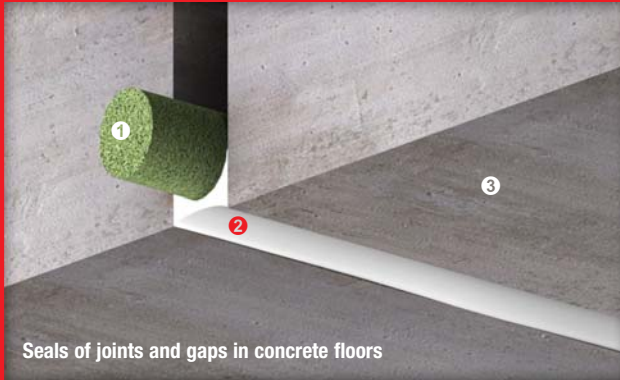

Seals of joints and gaps in concrete floors

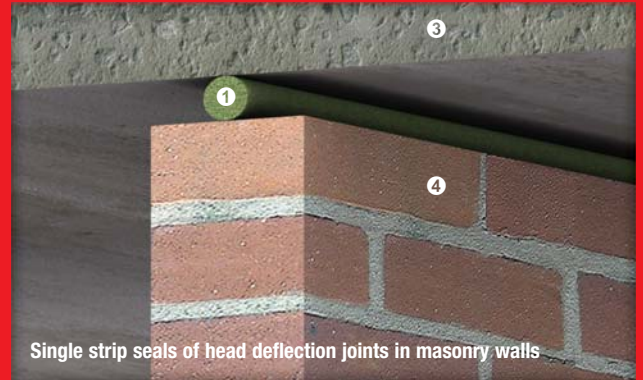

Single strip seals of head deflection joints in masonry walls

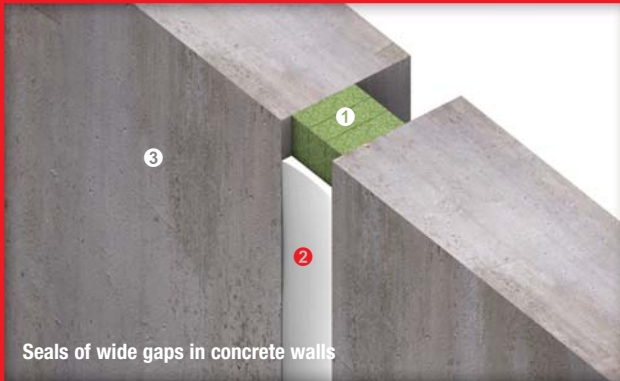

Seals of wide gaps in concrete walls

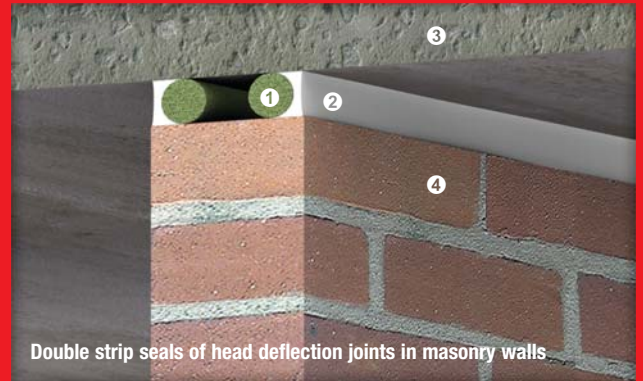

Double strip seals of head deflection joints in masonry walls

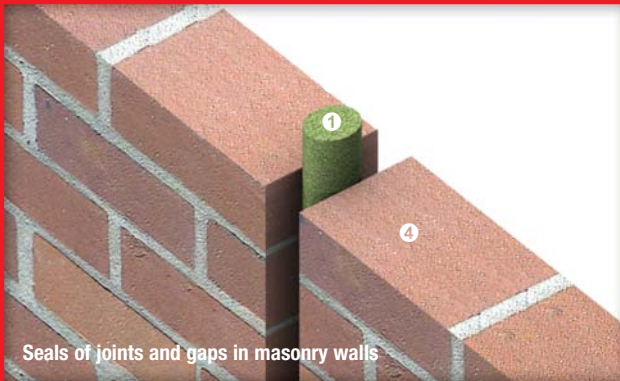

Seals of joints and gaps in masonry walls

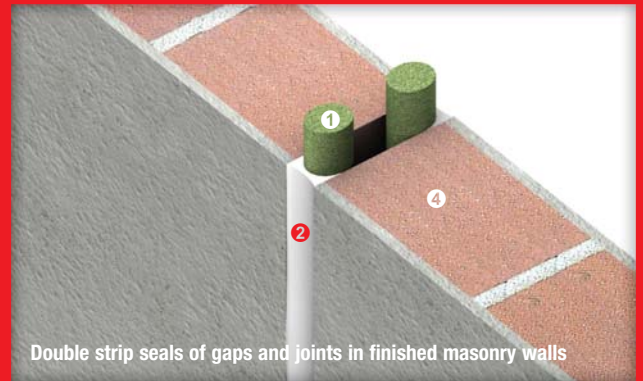

Double strip seals of gaps and joints in finished masonry walls



Seals of joints and gaps in finished masonry walls

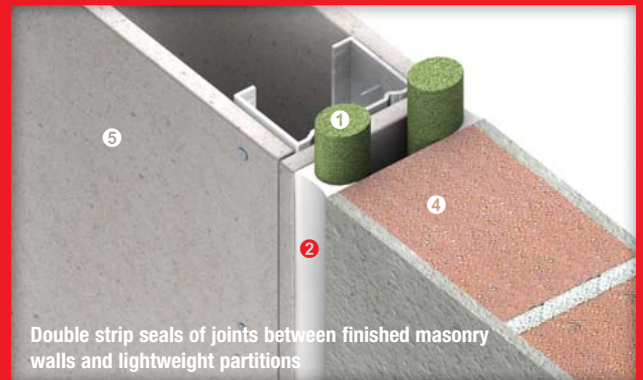

Double strip seals of joints between finished masonry walls and lightweight partitions

Up to -/240/240 fire resistance in accordance with the requirements of BS 476: Part 20: 1987 and/or AS 1530: Part 4: 2005, depending on applications and types of penetrating elements

- ① PROMASEAL® IBS™ dimension in accordance with the table on page 34
- ② Joints and gaps filled with PROMASEAL®-A Acrylic Sealant, minimum depth in accordance with the table on page 34
- ③ Fire resistant concrete floors or walls
- ④ Fire resistant masonry walls
- ⑤ Fire resistant steel/timber framed lightweight partitions

PROMASEAL® IBS™ is a fire resistant, flexible foam strip which, when placed in joints and around service penetrations in floors and walls, will maintain the fire resistance of the separating element. In most instances the addition of PROMASEAL®-A Acrylic Sealant is necessary. On some occasions a non fire resistant sealant can be applied. See table at below right on this page for control joints.

PROMASEAL® IBS™ is a factory made product and can be easily verified as being installed in the correct manner.

PROMASEAL® IBS™ generally is used in lieu of a fire resistant sealant where the specifying authority or certifying body is concerned that the correct depths of sealant or the correct type sealant may not be applied by the contractor.

PROMASEAL® IBS™ accommodates movement in building services, e.g. the expansion or contraction of metal pipes, while maintaining the integrity of the penetration. It can be used for external wall joints in conjunction with an exterior grade sealant.

PROMASEAL® IBS™ is not designed for use in control joints that are designed to accommodate high or ongoing movement.

As a general rule, PROMASEAL® IBS™ should be compressed by approximately 20% when inserted into the joint or gap. This will then accommodate small movements. If movement is an important factor in the choice of product, please refer to details of PROMASEAL® FyreStrip on [page 38](#).

General Application Considerations

Please refer to the **General Application Considerations** on [page 2](#) in conjunction with the following.

It is important that the user be aware of the type of services and the dimensions of the gaps that will be left around the services that are to be sealed. Valid supporting evidence that the proposal consists of a tested system may be required. This may vary from country to country, depending upon the way the test results are interpreted and how local regulations are applied. Applications that have been tested in the ceilings, floors, walls and partitions (with an equal or greater fire resistance level) include:

- Up to 120 minutes for electrical cables supported with cable tray through lightweight partitions;
- Up to 120 minutes for bundles of electrical cables through lightweight partitions;
- Metal pipes up to 150mm nominal diameter through concrete floors;
- Up to 60 minutes for metal pipes up to 60mm nominal diameter through steel/timber framed ceilings;
- Up to 120 minutes for metal pipes up to 100mm nominal diameter through lightweight partitions;
- Fire dampers through floors and walls;
- Fibre reinforced concrete drainage pipes through floors;
- Non combustible insulation through floors and walls;
- Gaps and joints in floors and walls, control joints in lightweight partitions;
- Deflection head joints.

Dimensions

PROMASEAL® IBS™ is supplied in plastic bags and is ready for use. It is available in the following standard dimensions:

- 16mm diameter round strip
- 22mm diameter round strip
- 29mm diameter round strip
- 38mm diameter round strip
- 50mm x 20mm thick flat strip
- 100mm x 10mm thick flat strip

Guide To Seals Of Joints & Gaps

Butt Joints

Where joints occur between lengths of PROMASEAL® IBS™ and sealant is not used, the fire resistance of the system can be maintained by applying an additional 50mm long strip of PROMASEAL® IBS™ over the joint on either the exposed or unexposed face. Alternatively, apply PROMASEAL®-A Acrylic Sealant over the butt joint to a depth of 5mm with a minimum of 5mm coverage on either side of the butt joint.

Intermediate Joint Widths

For joint widths that fall between the dimensions in the chart below, use the PROMASEAL® IBS™ applicable for the next size up.

Uneven Joint Widths

Joints in floors, concrete walls and plasterboard walls are generally even. However, joints in masonry walls and between floor slabs and walls are likely to vary. In these instances it is recommended that wherever possible install the size of PROMASEAL® IBS™ which will accommodate the widest part of the joint. It is also recommended that sealant is applied over the top of the PROMASEAL® IBS™ if there is any likelihood of the uneven surface of the substrates resulting in through gaps between the PROMASEAL® IBS™ and the building element.

Dimensions Of PROMASEAL® IBS™ For Seals In Gaps And Joints Of Floors Or Walls

Configuration	Maximum joint width (mm)	Nominal dimension of IBS™ (mm)	Minimum depth of non fire resistant sealant (mm)	Maximum fire resistance
System to non fire exposed side only	18	22	9 (optional)*	-/240/120
	30	38	12 (optional)*	-/240/120
	35	38	12	-/240/120
	54	60	18	-/180/120
	65	80	20	-/180/120
System to fire exposed side only	18	22	9 (optional)**	-/240/240
	18	22	12	-/240/240
	35	38	12	-/240/240
	54	60	18	-/240/240
	65	80	20	-/240/240
System to mid depth of element	18	22	Not required	-/240/120
	30	38	Not required	-/180/90
	50	60	5	-/240/120

* If sealant is not used in this application the fire resistance achieved will be -/180/90. For joints up to 30mm wide it is possible to install a 10mm thick PROMASEAL® IBS™ into the joint on the element's side exposed to fire without a sealant coating.

** If sealant is not used in this application the fire resistance achieved will be -/240/180. For joints up to 30mm wide it is possible to install a 12mm thick PROMASEAL® IBS™ from the element's side unexposed to fire without a sealant coating.

The non fire resistant sealant consists of acrylic, silicone or polyurethane based materials. To install PROMASEAL® IBS™, compress and insert into the joints. For gaps up to 30mm, it is possible to install the PROMASEAL® IBS™ in the centre of the depth/thickness of the floor or wall without a sealant fill. The fire resistance achieved depends on the existing fire resistance level of the building element in which the PROMASEAL® IBS™ is installed.

Installation

The fire resistance achieved with PROMASEAL® IBS™ will vary depending on applications and types of the penetrating element, and the orientation of both application and element. Please consult Promat for the latest fire test approvals.

Metal pipes through cored or existing openings

Fire resistance performance up to -/180/180 with Fyreguard or up to -/180/- without Fyreguard.

Please select the correct dimensions of PROMASEAL® IBS™ to suit the gaps around the penetrating pipes. The maximum gap width should not exceed 35mm.

PROMASEAL® IBS™ will always require a coating layer of PROMASEAL®-A Acrylic Sealant.

Please note the following general user guide:

For gaps up to 10mm	See PROMASEAL®-A Acrylic Sealant for control joint seals on page 28
For gaps 10-13mm	16mm thick PROMASEAL® IBS™
For gaps 13-18 mm	22mm thick PROMASEAL® IBS™
For gaps 18-24 mm	29mm thick PROMASEAL® IBS™
For gaps 24-35 mm	38mm thick PROMASEAL® IBS™

Set a 5mm thick PROMASEAL® IBS™ below the surface of the penetrating element. Apply a 10mm thick sealant along the pipe and the taper to 30mm onto the surface of the element.

Metal pipes through PROMASEAL® Mortar backfill

Fire resistant performance up to -/240/120.

There may be requirements in some instances for the fire seal to accommodate the movement of metal pipes. In these cases, before PROMASEAL® Mortar is installed, wrap the PROMASEAL® IBS™ (cut from a 100mm x 10mm thick flat strip) around the pipes. Hold in place with a wire tie or adhere with PROMASEAL® AN Acrylic Sealant.

It is also prudent to provide some separation between the PROMASEAL® Mortar and any copper pipe to ensure that there will be no chemical reaction between the mortar and the copper.

For floor applications, the PROMASEAL® IBS™ should project some 40mm above the mortarline. Apply PROMASEAL®-A Acrylic Sealant over the PROMASEAL® IBS™ to a depth of 45mm from the mortar and 20mm from the pipe surface. Form a cone shape similar to a volcano.

For wall applications, the PROMASEAL® IBS™ is installed to the full thickness of the wall and should remain flush with both sides of the wall.

Metal pipes through 60 minute fire resistant ceilings with two layer 16mm plasterboard

Fire resistant performance up to -/60/60 or -/60/-.

For pipes up to 100mm nominal diameter with a maximum 15mm aperture, install 50mm x 20mm thick flat PROMASEAL® IBS™ around the pipe to finish flush with the side of the ceiling. Apply PROMASEAL®-A Acrylic Sealant to a depth of 5mm by extending 30mm onto the ceiling surface. It is necessary to install a steel wire cage above the ceiling if insulation criteria is required. Please see the above said **metal pipes through cored or existing openings**.

Combustible insulation through floors, walls and partitions

Where insulated pipes pass through openings in floors, walls or partitions, it is essential that any combustible insulation be protected. This can be achieved using fire collars, PROMASEAL® FlexiWrap or PROMASEAL® Graftitex.



Up to -/240/120 fire resistance in accordance with the requirements of BS 476: Part 20: 1987 and/or AS 1530: Part 4: 2005, depending on applications and types of penetrating elements

- 1 PROMASEAL® IBS™ dimension in accordance with the table on page 34
- 2 Joints and gaps filled with PROMASEAL®-A Acrylic Sealant, minimum depth in accordance with the table on page 34
- 3 PROMASEAL® Wrap
- 4 Non-combustible metal pipes
- 5 Steel sleeve to close off cavity
- 6 Fire resistant steel/timber framed lightweight partition

If these options are not practical, then the combustible insulation must be replaced with a non-combustible insulation for a minimum distance of 400mm on each side of and passing through the floor, wall or partition.

Any gaps no more than 30mm between a floor opening and pipe insulation should be sealed with PROMASEAL® IBS™ compressed into the gap, set approximately 5mm below the floor surface. PROMASEAL®-A Acrylic Sealant is applied over the PROMASEAL® IBS™ to a depth of 20mm and on to the floor surface for minimum overlap of 15mm. A maximum pipe diameter of 75mm with 25mm of insulation applies.

For walls and partitions, apply the removal of the insulation and reinstatement using non-combustible insulation. The maximum gap between the insulation and wall is 10mm. Insert 22mm thick PROMASEAL® IBS™ into this gap, set approximately 10mm from the wall surface and apply PROMASEAL®-A Acrylic Sealant to a depth of 20mm and extend onto the surface of the element to give minimum 10mm overlap on the element.

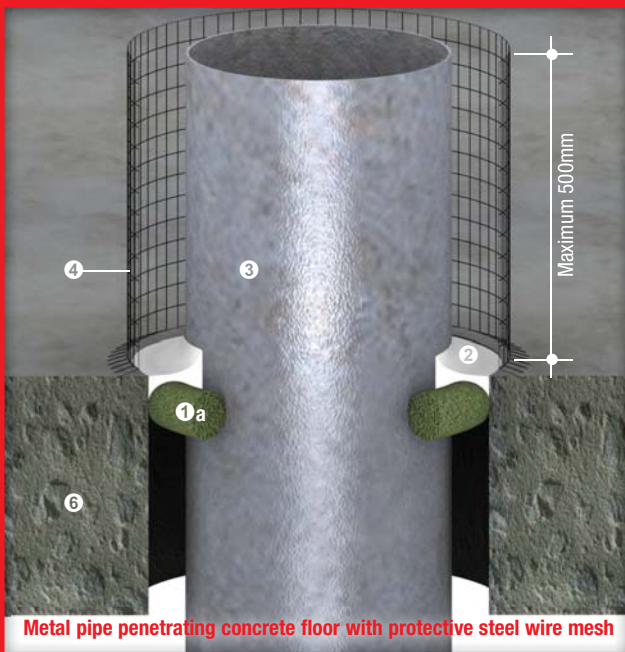
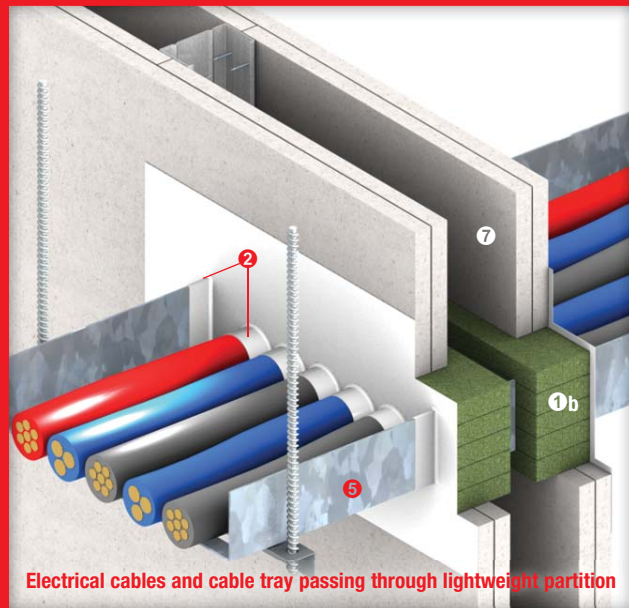
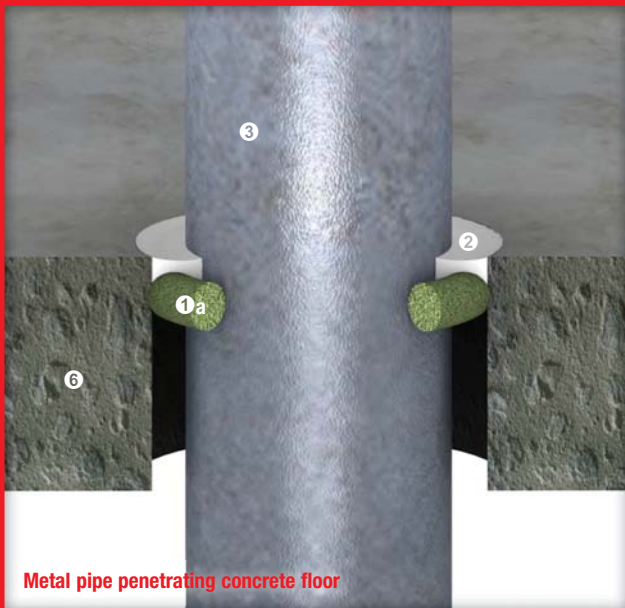

Up to ~240/240 fire resistance in accordance with the requirements of BS 476: Part 20: 1987 and/or AS 1530: Part 4: 2005, depending on applications and types of penetrating elements

- ①a PROMASEAL® IBS™ dimension in accordance with the table on page 35
- ①b PROMASEAL® IBS™ thickness in accordance with the table on page 34
- ② Joints and gaps filled with PROMASEAL®-A Acrylic Sealant, minimum thickness in accordance with the table on page 34
- ③ Non combustible metal pipes*
- ④ Steel wire mesh to maintain distance from combustible materials where insulation criteria is required (please consult Promat for details)
- ⑤ Electrical cables supported with cable tray or steel trunking
- ⑥ Fire resistant concrete floors
- ⑦ Fire resistant steel/timber framed lightweight partition

*Use of copper pipes instead might affect the overall fire resistance performance of the penetration seal due to the fact that copper is a high conductor of heat. Please consult Promat for application of PROMASEAL® IBS™ on penetration seals of copper pipes. Alternatively, apply a PROMASEAL® Wrap or mesh guard.

Installation

Fibre cement pipes through concrete/masonry floors

Any gap between the opening in the floor and the pipe should be no more than 30mm and should be sealed with PROMASEAL® IBS™ compressed into the gap and set approximately 5mm below the surface of the floor. PROMASEAL®-A Acrylic Sealant to be applied over the PROMASEAL® IBS™ to a depth of 20mm and onto the surface of the floor for a minimum overlap of 15mm. The maximum pipe diameter approved is 450mm.

For this application, only fibre cement pipes that have been shown to pass a fire test of the same duration as required for the seal, and not suffer from explosive delamination or cracking can be used.

Electrical cables supported with cable tray through lightweight partitioons

Fire resistance performance up to ~120/-.

Install 50mm x 20mm thick PROMASEAL® IBS™ on both sides of the partition with the IBS™ flush to the surface of the partition. The maximum opening dimension is 1520mm wide x 95mm high. The IBS™ will compress by approximately 20% when in place.

Apply a nominal 3mm film of PROMASEAL®-A Acrylic Sealant over the PROMASEAL® IBS™ and extend it approximately 30mm onto the surface of the partition. The sealant is extended 10mm out along the length of the electrical cables.

Insulation Criteria On Various Penetration Seals

Please refer to the **General Application Considerations** on page 2 in conjunction with the following. Where insulation criteria is required but not obtained with the PROMASEAL® IBS™ sealing systems, a steel mesh sleeve (or PROMASEAL® Wrap) should be installed around the pipe. The steel mesh should consist of a 20mm x 20mm x 1mm thick steel wire mesh set approximately 100mm from the service and extending some 500mm along the service from the wall or floor. Please consult Promat for details.

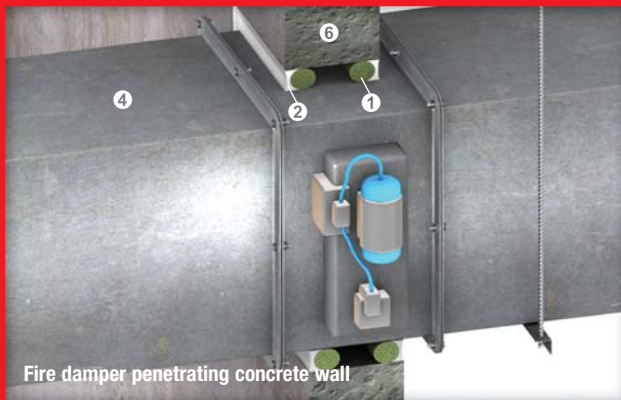
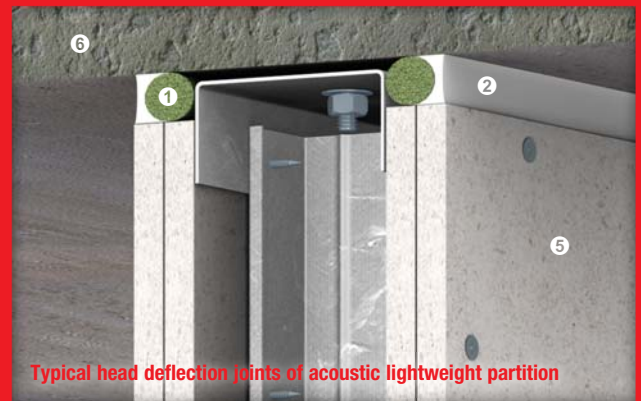
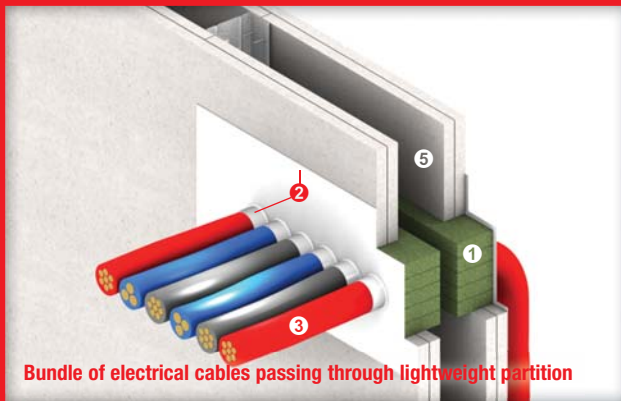

Up to -/240/240 fire resistance in accordance with the requirements of BS 476: Part 20: 1987 and/or AS 1530: Part 4: 2005, depending on applications and types of penetrating elements

- ① PROMASEAL® IBS™ thickness in accordance with the table on page 30
- ② Joints and gaps filled with PROMASEAL®-A Acrylic Sealant, minimum thickness in accordance with the table on page 30
- ③ Electrical cables
- ④ Fire dampers or steel ventilation ducts with appropriate support
- ⑤ Fire resistant steel/timber framed lightweight ceilings or partitions
- ⑥ Fire resistant concrete floors or walls

Installation

Bundles of electrical cables through lightweight partitions

Fire resistance performance up to -/180/180.

Electrical cables should, as well as is possible, be evenly spread along the width of the opening within the structure. PROMASEAL® IBS™ should be positioned either side of the cables so that they are sandwiched between two layers of 50mm x 20mm thick PROMASEAL® IBS™ with the PROMASEAL® IBS™ being on both sides of the partition and finishing flush with the partition surface.

Apply a nominal thickness of 3mm film of PROMASEAL®-A Acrylic Sealant over the PROMASEAL® IBS™ and extend some 30mm onto the surface of the partition. The sealant is extended 10mm out along the length of the electrical cables.

Fire dampers through concrete/masonry walls and lightweight partitions

Fire resistance performance up to -/120/- for openings up to 900mm x 600mm in concrete/masonry walls or lightweight partitions.

The fire dampers are sealed in walls using PROMASEAL® IBS™ inserted into a gap around the damper of maximum 30mm and minimum 15mm wide. The IBS™ is set 5mm in from the face of the wall and must be compressed no less than 20% of its diameter, e.g. for a 30mm gap use 38mm thick IBS™.

Apply PROMASEAL®-A Acrylic Sealant over the PROMASEAL® IBS™ to finish flush with the element surface. Steel angles are then placed over the sealant as part of the damper installation.

The fire resistance performance of the sealing system is up to 120 minutes for concrete/masonry walls and lightweight partitions, provided that the building elements has an equal or greater fire resistance level as the fire dampers.

The fire dampers must always be installed exactly in accordance with their tested method. Consultation with the relevant damper manufacturer should always take place to ensure that dampers are fully and properly installed. Incorrect installation and sealing of dampers to the substrate will result in premature failure of the fire resistant sealing system.

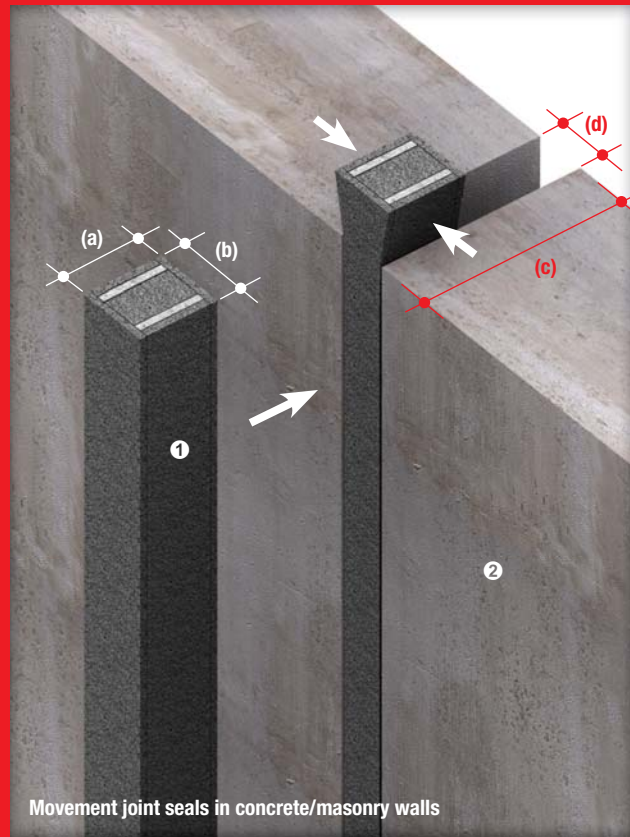
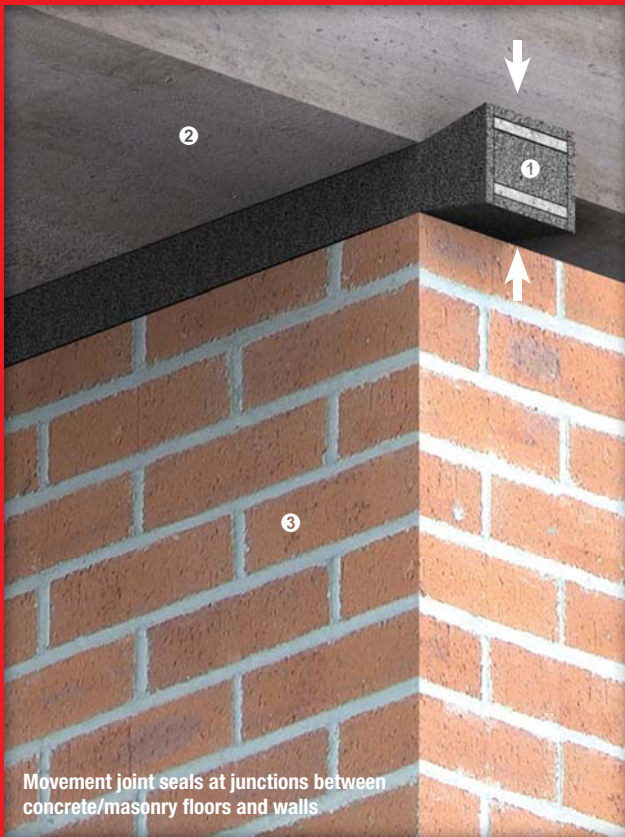

Up to -/240/240 fire resistance in accordance with the requirements of BS 476: Part 20: 1987 and/or AS 1530: Part 4: 2005, depending on applications and types of penetrating elements. Movement joints at the top of the hollow block and cavity walls AND the cavity within the hollow block walls must be sealed for a minimum one strip of PROMASEAL® FyreStrip, otherwise the hollow block and cavity walls will need to be capped

- ① PROMASEAL® FyreStrip
- ② Fire resistant concrete/masonry floors or walls
- ③ Brick walls

Code no.		FS 20	FS 40	FS 50	FS 80	FS 100
(a) Depth of FyreStrip	mm	70* 90	70* 90	90	100	120
(b) Width of FyreStrip	mm	28	46	56	84	124
(c) Minimum thickness of penetrating elements	mm	170 (-/240/240) 150 (-/180/180) 120 (-/120/120)	170 (-/240/240) 150 (-/180/180) 120 (-/120/120)	170 (-/240/240) 150 (-/180/180) 120 (-/120/120)	170 (-/240/240) 150 (-/180/180) 120 (-/120/120)	170 (-/240/240) 150 (-/180/180) 120 (-/120/120)
(d) Minimum gap width for insertion of FyreStrip	mm	16	24	32	48	64
Minimum gap width at full compression	mm	12	16	24	36	44
Maximum gap width at full expansion	mm	20	40	50	80	100

*Up to -/240/- fire resistance in accordance with the requirements of BS 476: Part 20: 1987. Movement joints at the top of the hollow block and cavity walls AND the cavity within the hollow block walls must be sealed for a minimum one layer of PROMASEAL® FyreStrip

Clockwise from right

Insertion of PROMASEAL® FyreStrip for movement joint seals between concrete columns and wall curtains at the National Trade Union Congress Centre, Singapore.

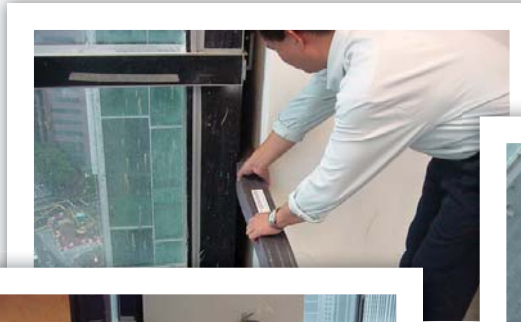

Position the FyreStrip horizontally (left) towards the wall joint. Use two pieces of thin flat steel to ease the insertion if necessary. Push the FyreStrip into the joint (below).

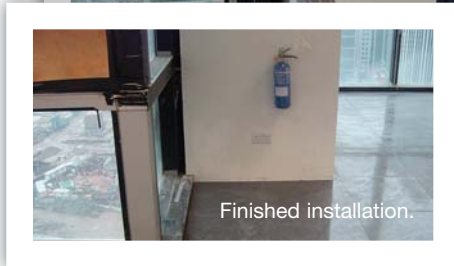

PROMASEAL® FyreStrip is a highly compressible, flexible, fire resistant expansion strip seal which is used where movement joints are formed in the structure of a building. It consists of layers of PROMASEAL® Grafitex intumescent material bonded to a special foam and it has been successfully tested for up to 240 minute fire resistance for movement joint seals within concrete/masonry compartment floors and walls (with an equal or greater fire resistance level).

The flexibility of PROMASEAL® FyreStrip is suitable for use in a variety of configurations. The fire resistance performance of PROMASEAL® FyreStrip will vary depending on applications and types of the penetrating elements. The gap width for which the FyreStrip will be inserted and the orientation of the insertion will affect the level of its fire resistance performance.

PROMASEAL® FyreStrip has been tested up to 240 minute fire resistance in accordance with the criteria of BS 476: Part 20: 1987 and AS 1530: Part 4: 2005 for high movement control joints in building elements. These typical applications include:

- Joints between old and new constructions that are aligned, i.e. the existing building is being extended.
- Joints in floor slabs that are used for vehicles and require a high degree of flexibility.
- Gaps between floor slabs and fascia panels.

Selection Of Correct Materials

The thickness of PROMASEAL® FyreStrip is determined by the minimum or maximum width of the gap expected during the lifetime of the building element. The thicknesses should not be less than the maximum expected widths (please refer to the table on page 38). The depth of PROMASEAL® FyreStrip is a function for the gap width and the required fire resistance performance.

PROMASEAL® FyreStrip is available in 1000mm lengths.

It may be readily cut to suit a particular length. When more than one length is required for sealing a joint, ensure that the two strips are tightly abutted so that there is no gap between the adjoining ends. At the ends of each joint, ensure the strip is fitted tight to the adjoining surface.

If a smoke or water seal is required, apply a suitable sealant in accordance with the manufacturer's instructions.

PROMASEAL® FyreStrip is non loadbearing. If the area of installation is trafficable, a suitable plate should be fixed over the joint. Such plates must also allow for the expected movement.

PROMASEAL® FyreStrip is suitable for use in concrete/masonry floors and walls with a fire resistance level equal or greater than 240 minutes. For lightweight partitions, 120 minute fire resistance can be achieved in movement joints up to a maximum gap width of 55mm.

Installation

As the thickness of PROMASEAL® FyreStrip is determined by the minimum or maximum width of the gap expected during the lifetime of the building element, it is therefore important to insert the PROMASEAL® FyreStrip so that the Grafitex sits parallel to the direction of movement. One end of the appropriate size of the FyreStrip is simply compressed between fingers and thumb until it can be inserted into the required gap. Make sure the label is facing outwards.

The strip can then be progressively pushed in to the joint. If it is difficult to insert, the strip may be knocked in to place with a hammer handle, rubber mallet or by placing a piece of timber along the length of the strip and knocking the timber.

Alternatively, the strip can be inserted in between two sleeves of sheet metal to provide ease of installation. Once in position the two sleeves can be withdrawn and reused. It is advisable to insert each strip progressively along its length.

For joints at the top of hollow block and cavity walls, the block must be sealed for a minimum of one course or the cavity wall will need to be capped on top. The strip must be centrally located in the wall or floor joint. In cold conditions it is advisable to store the strip in a warm atmosphere immediately prior to installation as this improves compressibility.

The strip may readily be cut to suit a particular length. When more than one length of PROMASEAL® FyreStrip is required in a joint, ensure the two pieces are butted tight together and there is no gap between the adjoining ends.

At the ends of each joint, it is essential to fit the strip to the adjoining surface. If a smoke or water seal is required, apply a suitable sealant according to the instructions of the sealant manufacturer.

If the area where the PROMASEAL® FyreStrip is installed is designed to be trafficable, a suitable plate should be fixed over the joint, always allowing for movement.

PROMASEAL® FyreStrip sealing systems are non loadbearing. It is advisable to place a visible warning sign near all barriers to identify its characteristics/inherent properties, with wording similar as follows:

WARNING: THIS IS A FIRE RESISTANT BARRIER. DO NOT DISTURB. DO NOT WALK OR PLACE ANY LOADS ON OR AGAINST THE BARRIER. IF THE BARRIER IS DAMAGED CONTACT (name of installer) IMMEDIATELY.

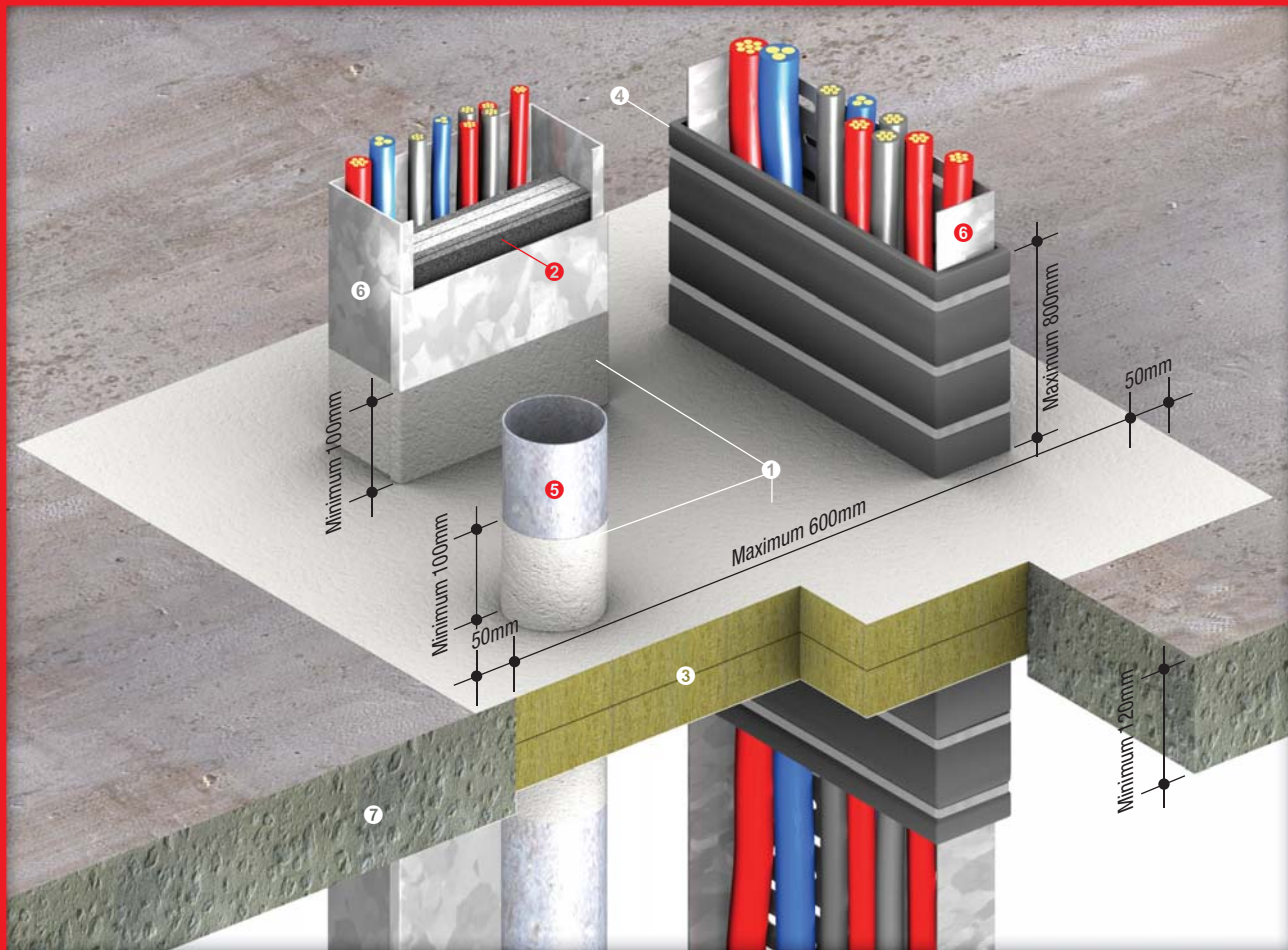

Up to -/120/120 fire resistance in accordance with the requirements of BS 476: Part 20: 1987, BS EN 1366: Part 3: 2009 and/or AS 1530: Part 4: 2005, depending on applications and types of penetrating elements; insulation time is the measured time to insulation failure on surface of the PROMASEAL® Bulkhead Sealer

In some instances, where insulation measured upon the penetrating elements is the required criteria, this time to insulation failure can be substantially shorter, e.g. metal pipes penetrating the floors. If insulation measured upon the penetrating elements is a specified performance criteria, please consult Promat about the use of PROMASEAL® Wrap

- ❶ PROMASEAL® Bulkhead Sealer coating (or PROMASEAL®-A Acrylic Sealant), with minimum 100mm length of coating on the penetrating elements measured from the openings
- ❷ PROMASEAL® Electrical Junction Seal (see page 55 for details)
- ❸ One layer of PROMASEAL® Bulkhead batten 50mm thick (coated both sides) x minimum 120kg/m³ for up to -/120/60* fire resistance or two layers of PROMASEAL® Bulkhead batten 50mm thick x minimum 120kg/m³ for up to -/120/120 fire resistance
*For performance up to -/120/90, minimum 170mm thick concrete or masonry floors are required.
- ❹ PROMASEAL® Wrap
- ❺ Non combustible metal pipes
- ❻ Electrical cables supported with cable tray or steel trunking
- ❼ Fire resistant concrete or masonry floors

PROMASEAL®-A Acrylic Sealant (not shown above) should be liberally applied to all joints and contact points between the Bulkhead barrier and items ❹ or ❺ AND between the barrier and the floor

PROMASEAL® Bulkhead Sealer System is made using high density mineral wool that is coated with PROMASEAL® Bulkhead Sealer. The coated mineral wool remains in-situ during a fire situation and forms a barrier against the passage of flame, smoke and toxic gases.

The system is the simplest of all fire stopping products to install. It is also one of, if not the most economical product to use. It can be installed in both concrete/masonry floors and walls (with an equal or

greater fire resistance level) and has been tested up to 120 minutes with various penetrating applications.

In many buildings, power cables (e.g. information technology and telecommunication services) are continuously added, altered and removed. PROMASEAL® Bulkhead Sealer System enables this process to be carried out with the minimum of mess and inconvenience.

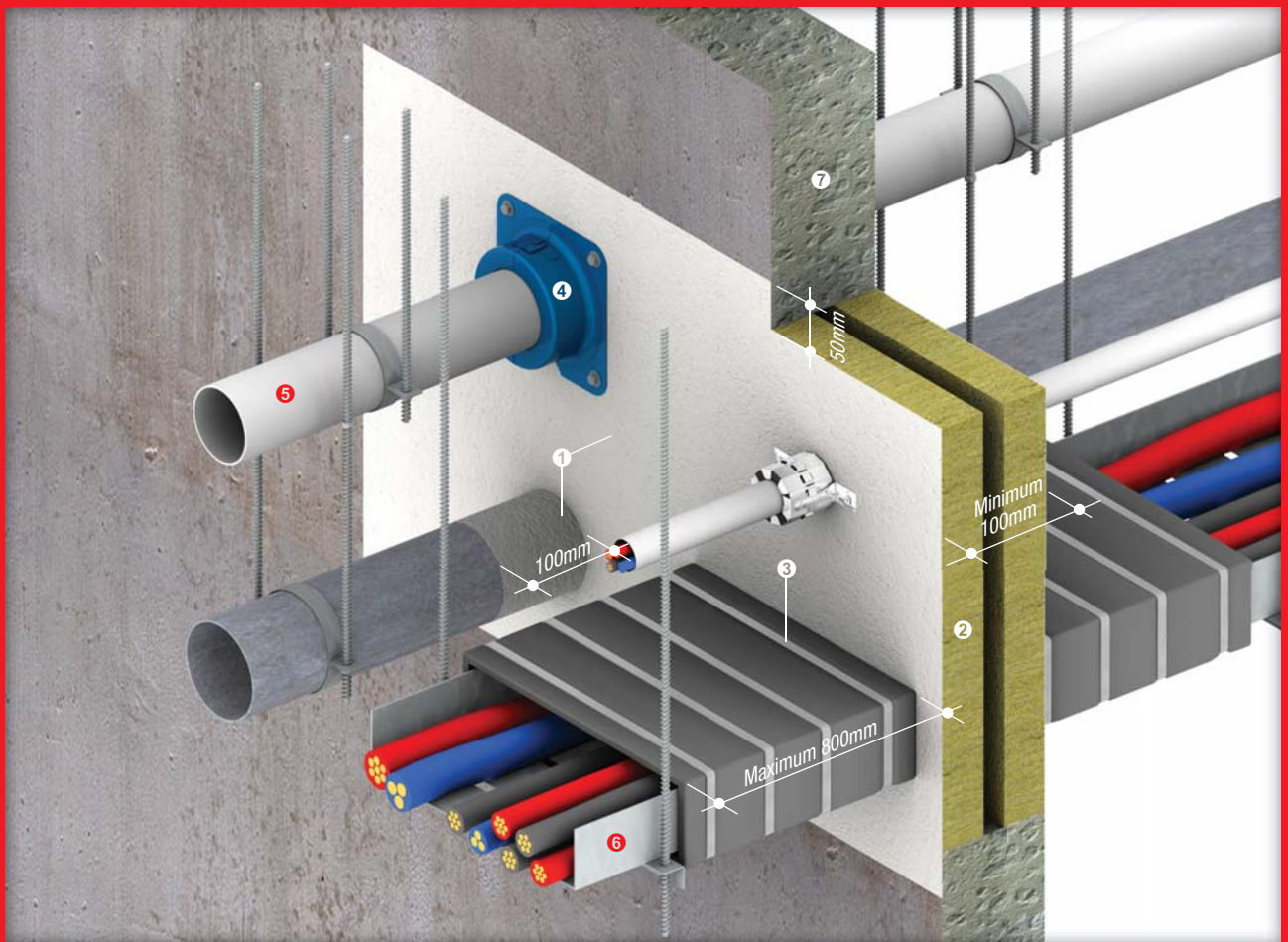

Up to -/120/120 fire resistance in accordance with the requirements of BS 476: Part 20: 1987, BS EN 1366: Part 3: 2009 and/or AS 1530: Part 4: 2005, depending on applications and types of penetrating elements; insulation time is the measured time to insulation failure on surface of the PROMASEAL® Bulkhead Sealer

In some instances, where insulation measured upon the penetrating elements is the required criteria, this time to insulation failure can be substantially shorter, e.g. metal pipes penetrating the walls. If insulation measured upon the penetrating elements is a specified performance criteria, please consult Promat about the use of PROMASEAL® Wrap

- ❶ PROMASEAL® Bulkhead Sealer coating (or PROMASEAL®-A Acrylic Sealant), with minimum 100mm length of coating on the penetrating elements measured from the openings
- ❷ One layer of mineral wool 50mm thick x 120kg/m³ for up to -/120/90 fire resistance or two layers of PROMASEAL® Bulkhead batten 50mm thick x minimum 120kg/m³ for up to -/120/120 fire resistance
- ❸ PROMASEAL® Wrap
- ❹ PROMASEAL® Retrofit Collar (square base) fixed through the batt with a threaded rod
- ❺ Non combustible plastic pipes with appropriate support within 300mm from both sides of the Bulkhead barrier
- ❻ Electrical cables supported with cable tray or steel trunking within 300mm from both sides of the Bulkhead barrier
- ❼ Fire resistant concrete or masonry walls

PROMASEAL®-A Acrylic Sealant (not shown above) should be liberally applied to all joints and contact points between the Bulkhead barrier and items ❸ or ❺ AND between the barrier and the floor

PROMASEAL® Bulkhead Sealer Systems are non loadbearing. It is advisable to place a visible warning sign near all barriers to identify its characteristics/inherent properties, with wording similar as follows:

Loadbearing systems are available. Please consult Promat for complete details.

WARNING: THIS IS A FIRE RESISTANT BARRIER. DO NOT DISTURB. DO NOT WALK OR PLACE ANY LOADS ON OR AGAINST THE BARRIER. IF THE BARRIER IS DAMAGED CONTACT (name of installer) IMMEDIATELY.

It is important to be aware of the types of services that will pass through the system. There may be a requirement to produce evidence that the relevant services passing through the barrier have been fully and properly subjected to professional fire testing. Applications that have been tested in walls (with an equal or greater fire resistance level) include:

- Electrical cables in bundles or supported with steel cable tray;
- Metal pipes up to 150mm nominal diameter. This would allow for the use of copper, brass or steel pipes of all sizes up to 150mm (subject to local regulations);
- uPVC pipes up to 100mm nominal diameter in combination with FC type PROMASEAL® Retrofit Collar (square base) or PROMASEAL® Wall Collar. This would allow for the use of the collar on plastic pipes of all sizes up to 100mm (subject to local regulations).
- Other plastic pipes with PROMASEAL® Conduit Collar.

Applications that have been tested in floors (with an equal or greater fire resistance level) include:

- Electrical cables in bundles or supported with steel cable tray;
- Electrical cable ducting or conduit;
- Steel pipes up to 100mm nominal diameter.

General Application Considerations

Other components of an integrated Promat fire stopping system can be used around services that penetrate floors or walls through oversize openings too large to be sealed with PROMASEAL®-A Acrylic Sealant, PROMASEAL® IBS™ or PROMASEAL® Pillows.

Where a floor or wall has an oversize opening for the services to pass through, all services are then directed through the opening. This has to be reinstated to maintain the fire resistance of the floor/wall.

Where insulation criteria for services is required, PROMASEAL® Wrap can be installed with the PROMASEAL® Bulkhead Sealer System.

PROMASEAL® Bulkhead Sealer System can be used in power stations and large industrial complexes where cables are carried through service tunnels.

In this industrial category, the use of fire protection is primarily due to the large financial exposure of insurance companies, not only for the building and assets but also the loss of production that could follow an unconfined fire.

Applications are common in hospitals and universities, particularly those that have laboratories. Services are usually directed along corridors, above ceilings and pass through fire resistant barriers above fire doors. It is difficult to reinstate masonry or block work around the services and other systems often prove awkward to install.

For steel or timber framed lightweight partitions, the number of services passing through the opening can mean that the board installer will not be able to reinstate the lining close enough to the services to allow the use of some systems or products. In this type of construction, the PROMASEAL® Bulkhead Sealer System is one of the most economical methods of sealing the opening.

PROMASEAL® Bulkhead Sealer System is especially useful under computer flooring or between the top of walls and floor slabs or roofs where services often pass through compartment walls and the cables are always being changed or added. However, it should be clearly noted that the system is not suitable for use where any movement is expected, e.g. deflection of floors or roofs.

Installation

Double layer system in concrete/masonry floors or walls

Fire resistance performance of the barrier system (not including penetrating services) is up to -/120/120.

All joints between the PROMASEAL® Bulkhead Sealer battens must not be coincident between layers and without cross junctions of butt joints. To apply the sealer system from one side only, it is permissible to seal any small gaps between the batten and penetrating services on the back of the first batten and on the face of the second batten. It is also acceptable to use PROMASEAL®-A Acrylic Sealant.

Ensure that any joints between adjacent batts are staggered by a minimum of 150mm.

To provide a neat appearance once the bulkhead system has been installed, apply masking tape around the perimeter of the opening at a distance of 50mm from the junction of the bulkhead system and the substrate. Coat this junction with nominal 2mm thickness of PROMASEAL® Bulkhead Sealer up to the tape. Once dry, remove the tape for a neat finish.

The installation method detailed above allows for access from one side only. If it is possible to access both faces of the floor/wall, repeat the application of the PROMASEAL® Bulkhead Sealer as above on both faces for a more professional appearance.

In the same manner, with the PROMASEAL® Bulkhead Sealer apply a coat to the whole surface of the barrier and all services that pass through the opening for a distance of 100mm from the face of both sides of the batten. Coat the services over their entire length where they pass through the thickness of the barrier. Seal any small gaps between the batten and penetrating service with PROMASEAL® Bulkhead Sealer or PROMASEAL®-A Acrylic Sealant. If insulation criteria is required install PROMASEAL® Wrap around the services and hold in position with steel straps or pipe clamps at 200mm centres.

Double layer system in concrete/masonry floors

Fire resistance performance of the barrier system (not including penetrating services) is up to -/120/120.

Maximum width permitted for any floor openings is 600mm, supported on the edges with a concrete ledge of minimum 20mm bearing or a minimum 20mm x 20mm x 1.2mm thick steel angle bolted to the floor at 600mm centres with M8 x 40mm steel anchor bolts.

If the opening exceeds 1500mm in length, the barrier must be supported on transverse joints at maximum 1500mm centres with 50mm x 50mm x 1.2mm thick steel angles fixed back to back. All gaps between the battens and the angle frames must be no greater than 5mm. All joints in the battens must be staggered by minimum 150mm between layers and not be coincident between layers or positioned on the steel angle frames.

Openings up to 300mm of width can be of unlimited length, provided they are supported on the edges with a concrete ledge of minimum 20mm bearing or a minimum 20mm x 20mm x 1.2mm thick steel angle bolted to the floor at 600mm centres with M8 x 40mm steel anchor bolts.

Cut the pre-coated battens to fit the opening. Trim the battens around the services with minimal gaps between services and battens, and seal the cut edges with PROMASEAL® Bulkhead Sealer.

Coat all exposed edges of the battens with a nominal 2mm thickness of PROMASEAL® Bulkhead Sealer. If there are any gaps that exceed 5mm, plug them with offcuts of PROMASEAL® Bulkhead Sealer batten for the thickness of the full batten and coat the exposed faces with PROMASEAL® Bulkhead Sealer.

Before placing the battens in position, apply a nominal 2mm thick film of PROMASEAL® Bulkhead Sealer over the entire mating surface of the exposed edges of the floor and the steel angles.

Continued on next page

Continued from previous page

Apply a bead of PROMASEAL®-A Acrylic Sealant between the floor and the steel angles to seal any surface irregularities.

In the same manner, with the PROMASEAL® Bulkhead Sealer apply a coat to the whole surface of the barrier and all services that pass through the opening for a distance of 100mm from the face of both sides of the batten. Coat the services over their entire length where they pass through the thickness of the barrier. Seal any small gaps between the batten and penetrating service with PROMASEAL® Bulkhead Sealer or PROMASEAL®-A Acrylic Sealant. If a PROMASEAL® Wrap is installed then the services need not be coated. Installation of PROMASEAL® Wrap will help increasing insulation criteria for certain services.

The temperature rise on services exposed to fire is dependent upon type and dimension of each service. Please consult Promat for details.

Single layer system coated on both sides of concrete/masonry floors

Fire resistance performance of the barrier system (not including penetrating services) is up to -/120/60 for floors from 120mm to 169mm thick and up to -/120/90 for floors above 170mm thick.

Maximum width permitted for any floor openings is 600mm, supported on the edges with a concrete ledge of minimum 20mm bearing or a minimum 20mm x 20mm x 1.2mm thick steel angle bolted to the floor at 600mm centres with M8 x 40mm steel anchor bolts.

If the opening exceeds 1500mm in length, the barrier must be supported on transverse joints at maximum 1500mm centres with 50mm x 50mm x 1.2mm thick steel angles fixed back to back. All gaps between the battens and the angle frames must be no greater than 5mm. Ensure these gaps in the battens are sealed with PROMASEAL® Bulkhead Sealer or PROMASEAL®-A Acrylic Sealant.

Openings up to 300mm of width can be of unlimited length, provided they are supported on the edges with a concrete ledge of minimum 20mm bearing or a minimum 20mm x 20mm x 1.2mm thick steel angle bolted to the floor at 600mm centres with M8 x 40mm steel anchor bolts.

Coat the joints between battens with a nominal 2mm thickness of PROMASEAL® Bulkhead Sealer and cover the joint with a 75mm wide batten of PROMASEAL® Bulkhead Sealer System. In such instances, fit the sealer system to allow for the cover strip to finish flush with the floor level.

Cut the pre-coated battens to fit the opening. Trim the battens around the services with minimal gaps between services and battens, and seal the cut edges with PROMASEAL® Bulkhead Sealer.

Coat all exposed edges of the battens with a nominal 2mm thickness of PROMASEAL® Bulkhead Sealer. If there are any gaps that exceed 5mm, plug them with offcuts of PROMASEAL® Bulkhead batten for the thickness of the full batten and coat the exposed faces with PROMASEAL® Bulkhead Sealer.

Before placing the battens in position, apply a nominal 2mm thick film of PROMASEAL® Bulkhead Sealer over the entire mating surface of the exposed edges of the floor and the steel angles.

Coat all services that pass through the opening with PROMASEAL® Bulkhead Sealer at minimum 100mm of distance from the face of both sides of the batten and the entire length of the services which pass through the batten. Seal any small gaps between the batten and penetrating services with PROMASEAL® Bulkhead Sealer.

For a neat appearance, once the bulkhead barrier system has been installed, apply masking tape around the perimeter of the opening at nominal 50mm of distance from the junction of the barrier system and the floor. Coat this junction with nominal 2mm thick PROMASEAL® Bulkhead Sealer up to the tape. Once dry, remove the tape for a neat and professional finish.

The temperature rise on services exposed to fire is dependent upon type and dimension of each service. Please consult Promat for details.

Double layer system in concrete/masonry walls or lightweight partitions

Fire resistance performance of the barrier system (not including penetrating services) is up to -/120/120 for walls of minimum 100mm thick.

Maximum height permitted for any wall openings is 1000mm. For openings greater than 500mm high, the width is limited to maximum 1m² of the opening. For openings up to 500mm high, the width is unlimited as long as the wall is structurally sound.

If the opening exceeds 1000mm in height, it must be reduced to either of the dimensions as described using the same construction materials as the wall element.

All joints in the battens must be staggered by minimum 150mm between layers and not be coincident between layers or positioned on the steel angle frames.

For lightweight partitions, the opening must be trimmed all round with the partition framing sections to close the wall cavity.

Cut the pre-coated battens to fit the opening. Each batten is placed in the opening with the coated face exposed and sitting flush with the outer surface of the wall/partition. Trim the battens around the services with minimal gaps between services and battens, and seal the cut edges with PROMASEAL® Bulkhead Sealer.

Coat all exposed edges of the battens with a nominal 2mm thickness of PROMASEAL® Bulkhead Sealer. If there are any gaps that exceed 5mm, plug them with offcuts of PROMASEAL® Bulkhead batten for the thickness of the full batten and coat the exposed faces with PROMASEAL® Bulkhead Sealer.

Before placing the battens in position, apply a nominal 2mm thick film of PROMASEAL® Bulkhead Sealer over the entire mating surface of the exposed edges of the wall/partition.

Coat all services that pass through the opening with PROMASEAL® Bulkhead Sealer at minimum 100mm of distance from the face of both sides of the batten and the entire length of the services which pass through the batten and cavity of the wall/partition. Seal any small gaps between the batten and penetrating services with PROMASEAL® Bulkhead Sealer. If a PROMASEAL® Wrap is installed then the services need not be coated. Installation of PROMASEAL® Wrap will help increasing insulation criteria for certain services.

For a neat appearance, once the bulkhead barrier system has been installed, apply masking tape around the perimeter of the opening at nominal 50mm of distance from the junction of the barrier system and the wall/partition. Coat this junction with nominal 2mm thick PROMASEAL® Bulkhead Sealer up to the tape. Once dry, remove the tape for a neat and professional finish.

The temperature rise on services exposed to fire is dependent upon type and dimension of each service. Please consult Promat for details.

All PROMASEAL® Bulkhead Sealer Systems described on this and the previous pages are non loadbearing. It is advisable to place a visible warning sign near all barriers to identify its characteristics/inherent properties, with wording similar as follows:

WARNING: THIS IS A FIRE RESISTANT BARRIER. DO NOT DISTURB. DO NOT WALK OR PLACE ANY LOADS ON OR AGAINST THE BARRIER. IF THE BARRIER IS DAMAGED CONTACT (name of installer) IMMEDIATELY.

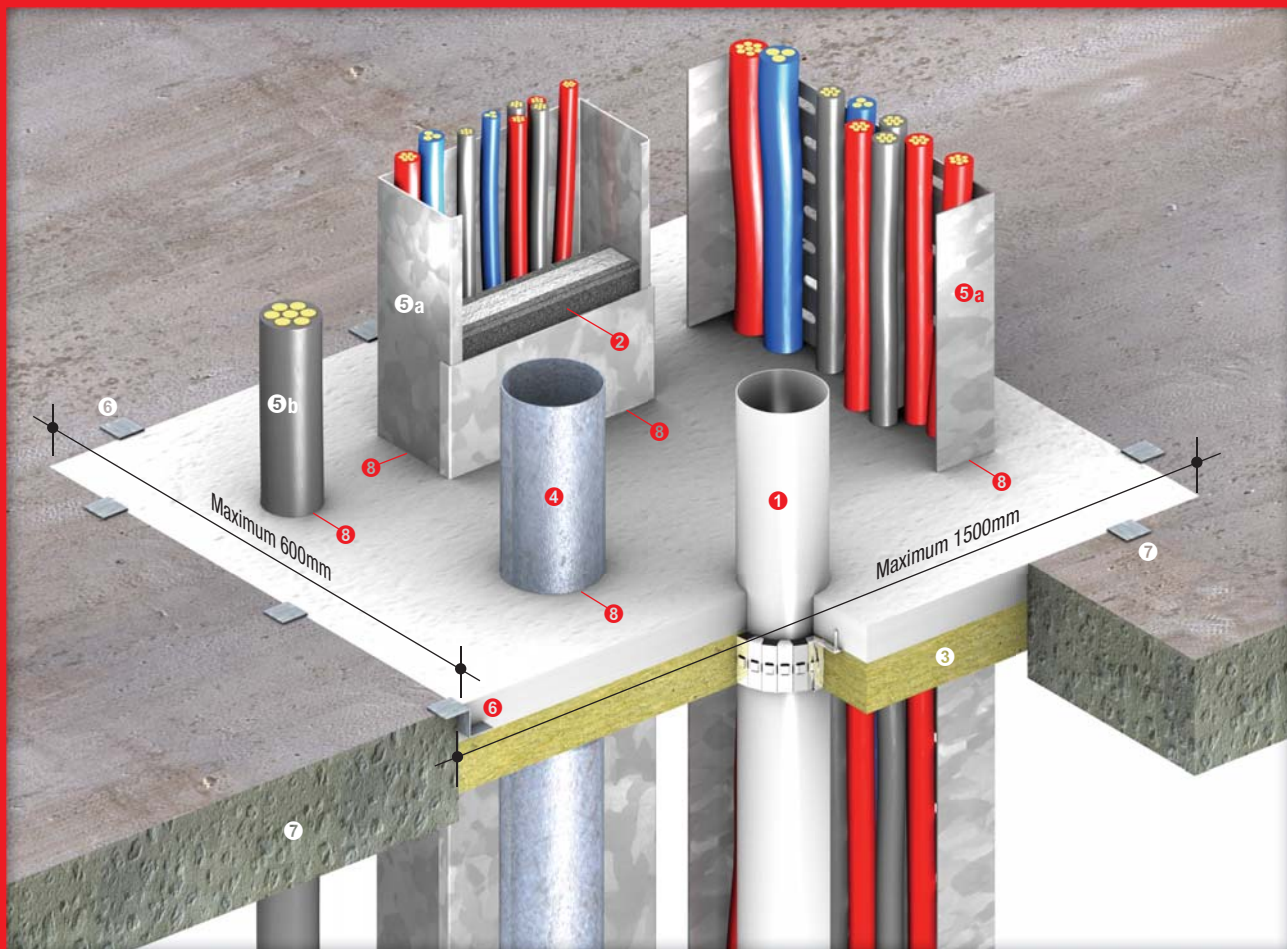

Up to -/240/240 fire resistance in accordance with the requirements of BS 476: Part 20: 1987, BS EN 1366: Part 3: 2009 and/or AS 1530: Part 4: 2005, depending on applications and types of penetrating elements; insulation time is the measured time to insulation failure on surface of the PROMASTOP® Cement

In some instances, where insulation measured upon the penetrating elements is the required criteria, this time to insulation failure can be substantially shorter, e.g. metal pipes penetrating the floors. If insulation measured upon the penetrating elements is a specified performance criteria, please consult Promat

- ① PROMASTOP® Cement 30mm thick for up to -/120/120 fire resistance or 40mm thick for up to -/240/240 fire resistance
- ② PROMASEAL® Electrical Junction Seal (see page 55 for details)
- ③ Mineral wool 50mm thick x 120kg/m³
- ④ Non combustible metal pipes
- ⑤a Electrical cables supported with cable tray or steel trunking
- ⑤b Electrical cables with Armaflex covering
- ⑥ Steel Z-clips 25mm wide at nominal 300mm centres
- ⑦ Fire resistant concrete/masonry floors
- ⑧ All joints and contact points caulked with PROMASEAL®-A Acrylic Sealant

PROMASTOP® Cement is a lightweight fire resistant cement supplied as a dry powder and to be mixed with water for on-site preparation. This fine grade cement powder is white in colour for ease of identification and has a quick setting time. When the product is set, it presents a hard surface finish and does not shrink regardless of temperature change. It is readily drilled for post installation of services.

PROMASTOP® Cement has been tested up to a 240 minute fire resistance with various penetration seals in concrete/masonry floors and walls (with an equal or greater fire resistance level). It is not applicable in lightweight partitions.

For floor applications, PROMASTOP® Cement can provide some degree of loadbearing capability depending on the thickness of the cement layer applied. Please consult Promat to determine the thickness to meet a specific loadbearing performance requirement.

PROMASTOP® Cement is white in colour and is supplied in convenient 20kg bags.

Installation

Openings in concrete/masonry floors and walls

Maximum dimensions of openings for PROMASTOP® Cement without the need to provide joints in the system are 1500mm wide x 600mm for floors and 600mm wide x 200mm for walls. For larger openings, please consult Promat.

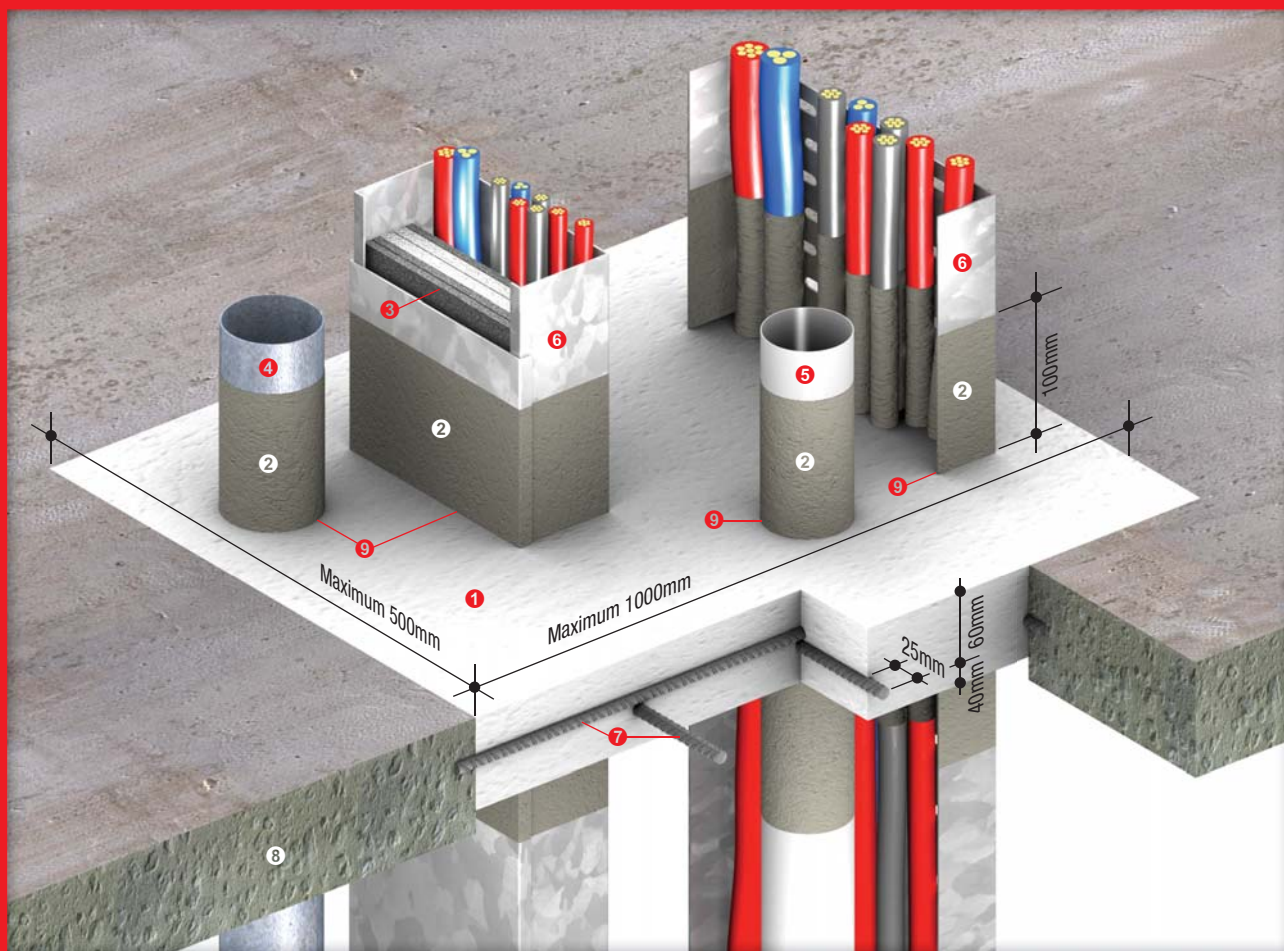

Up to -/360/360 fire resistance in accordance with the requirements of BS 476: Part 20: 1987, BS EN 1366: Part 3: 2009 and/or AS 1530: Part 4: 2005, depending on applications and types of penetrating elements; insulation time is the measured time to insulation failure on surface of the PROMASTOP® Cement

In some instances, where insulation measured upon the penetrating elements is the required criteria, this time to insulation failure can be substantially shorter, e.g. metal pipes penetrating the floors. If insulation measured upon the penetrating elements is a specified performance criteria, please consult Promat

- | | |
|---|--|
| <ul style="list-style-type: none"> ❶ PROMASTOP® Cement 100mm thick ❷ PROMASEAL® Bulkhead Sealer when required where insulation measured on the services is required (see pages 40 to 43 for details) ❸ PROMASEAL® Electrical Junction Seal (see page 55 for details) ❹ Non combustible metal pipes ❺ Non plastic pipes | <ul style="list-style-type: none"> ❻ Electrical cables supported with cable tray or steel trunking ❼ Steel reinforcement bars 12mm thick at 250mm centres ❽ Fire resistant concrete/masonry floors ❾ All joints and contact points caulked with PROMASEAL®-A Acrylic Sealant |
|---|--|

Installation in concrete/masonry floors

For loadbearing capabilities, an unpenetrated floor opening of 1000mm x 500mm with 100mm thick reinforced PROMASTOP® Cement can achieve up to 360 minute fire resistance performance after which it successfully supports 1000kg of loading.

An unpenetrated floor opening of 1000mm x 600mm with 50mm mineral wool and 40mm thick unreinforced PROMASTOP® Cement will support 7.56KN of loading. Similarly, 70mm thick unreinforced PROMASTOP® Cement will support 10.21KN of loading. However, these are non fire tested and non penetrated specimens.

Due to the likelihood of building movement, it is advisable to place a steel or equivalent reinforcement over the barrier where foot traffic is expected and a visible warning sign near all barriers to identify its characteristics/inherent properties, with wording similar as follows:

WARNING: THIS IS A FIRE RESISTANT BARRIER. DO NOT DISTURB. DO NOT WALK OR PLACE ANY LOADS ON OR AGAINST THE BARRIER. IF THE BARRIER IS DAMAGED CONTACT (name of installer) IMMEDIATELY.

Installation in concrete/masonry walls

Where the aperture is within a hollow block or cavity wall, the cavities must be backfilled all round with PROMASTOP® Cement.

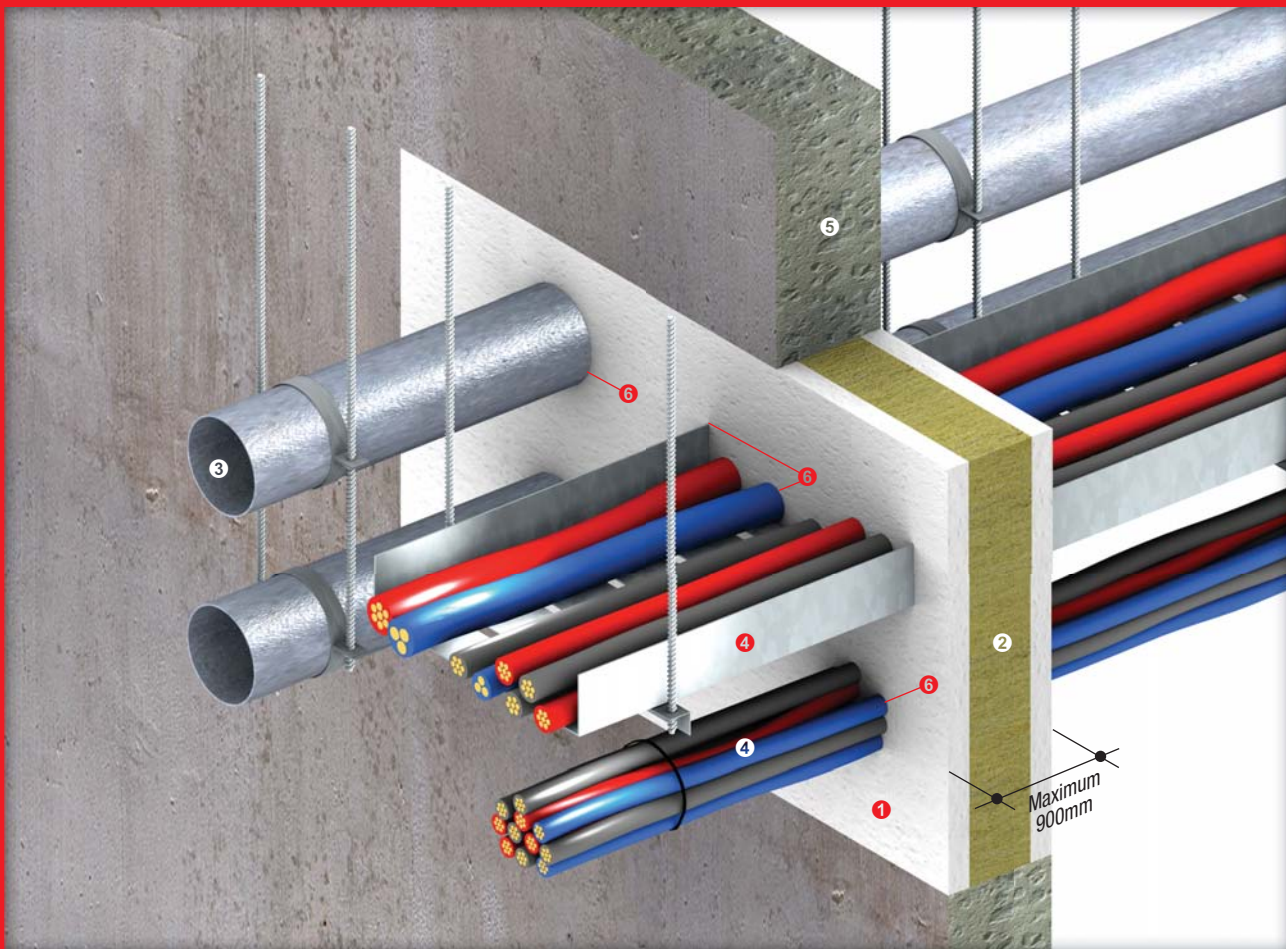

Up to -/240/240 fire resistance in accordance with the requirements of BS 476: Part 20: 1987, BS EN 1366: Part 3: 2009 and/or AS 1530: Part 4: 2005, depending on applications and types of penetrating elements; insulation time is the measured time to insulation failure on surface of the PROMASTOP® Cement

In some instances, where insulation measured upon the penetrating elements is the required criteria, this time to insulation failure can be substantially shorter, e.g. metal pipes penetrating the walls. If insulation measured upon the penetrating elements is a specified performance criteria, please consult Promat

- | | |
|--|--|
| <p>❶ PROMASTOP® Cement 25mm thick for up to -/120/120 fire resistance or 50mm thick for up to -/240/240 fire resistance</p> <p>❷ Mineral wool 50mm thick x 140kg/m³</p> <p>❸ Non combustible metal pipes with appropriate support</p> | <p>❹ Electrical cables with or without supporting cable tray/steel trunking</p> <p>❺ Fire resistant concrete/masonry floors</p> <p>❻ All joints and contact points caulked with PROMASEAL®-A Acrylic Sealant</p> |
|--|--|

Guide To Coverage And Mixing

When mixed with 15 to 19 litres/kg of clean water, a 20kg bag will produce approximately 25 litres of mix which will cover an area approximately 1m² at 25mm deep or 0.5m² at 50mm deep. This equates to approximately 1.3 x 20kg bags per m² of clear opening at 30mm deep or 1.7 x 20kg bags at 40mm deep. Other usage depths may be calculated directly from these figures as a general guidance. The final yield will depend upon the volume of water used.

PROMASTOP® Cement can be mixed to a consistency to suit the application. For floors, if services are close together, a wetter, “pourable” mix is preferred. For walls, it is always preferable to use a dry, “packing” mix. The amount of water used will also depend on ambient weather conditions at the time of mixing, but do not use a ratio of less than 2 : 1.

“Packing” mix, add 2kg of cement compound to 1.35 litres of water.

“Pourable” mix, add 2kg of cement compound to 1.8 litres of water.

For best surface finish use a ratio of 2 : 1.33 (cement : water). Note should be taken that the order of mixing cement compound and water is important as it will affect the consistency of the mix. Always add cement compound into water and not the opposite.

The mix will remain useable for approximately 30 minutes but this will depend upon the weather conditions and amount of water used. Do not attempt to remix by adding water after setting has commenced.

In some applications it may be necessary to provide bond breakers around services that may move as a result of natural building or thermal movement. This can be achieved using PROMASEAL® IBS™ (see pages 36 and 37 for details). Always apply a bead of PROMASEAL®-A Acrylic Sealant at the junction of the services and the cement as this will provide a smoke, water and movement seal.

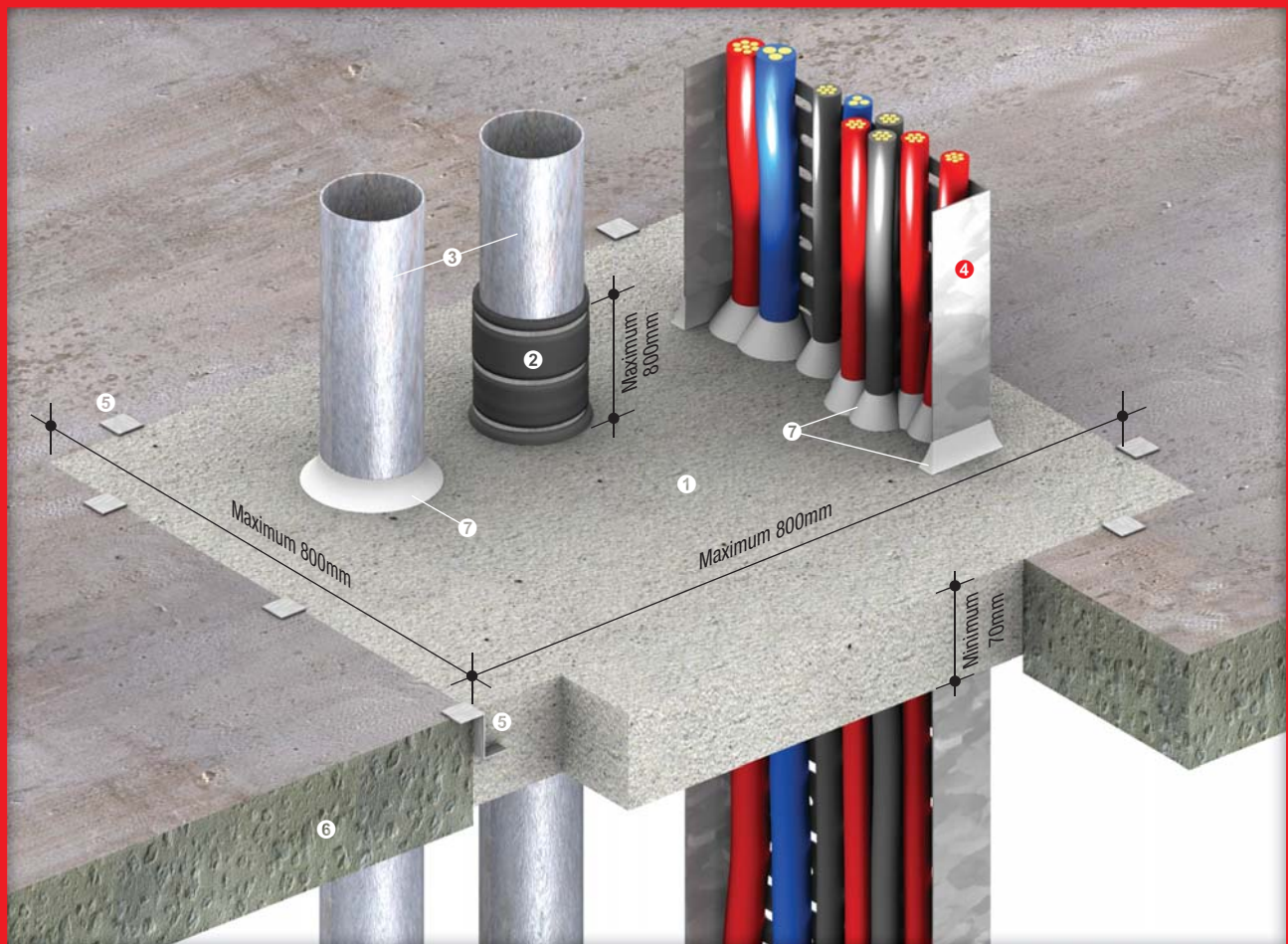

Up to -/240/240 fire resistance in accordance with the requirements of BS 476: Part 20: 1987, BS EN 1366: Part 3: 2009 and/or AS 1530: Part 4: 2005, depending on applications and types of penetrating elements; insulation time is the measured time to insulation failure on surface of the PROMASEAL® Mortar

In some instances, where insulation measured upon the penetrating elements is the required criteria, this time to insulation failure can be substantially shorter, e.g. metal pipes penetrating the floors. If insulation measured upon the penetrating elements is a specified performance criteria, please consult Promat about the use of PROMASEAL® Wrap

- | | |
|---|---|
| ① PROMASEAL® Mortar | ⑤ Steel Z-clips 25mm wide at nominal 300mm centres |
| ② PROMASEAL® Wrap | ⑥ Fire resistant concrete/masonry floors |
| ③ Non combustible metal pipes | ⑦ All joints and contact points caulked with PROMASEAL®-A Acrylic Sealant |
| ④ Electrical cables supported with cable tray or steel trunking | |

PROMASEAL® Mortar is a lightweight, fire resistant, cement based product, supplied as a pre-mixed, grey powder to which water is added. It has been tested up to a 240 minute fire resistance with various penetration seals in concrete/masonry floors and walls (with an equal or greater fire resistance level).

Advantages of PROMASEAL® Mortar include:

- Clean and economical.
- The mortar weighs approximately 700kg per m³ as compared to 2400kg of normal concrete and 1600-1800kg of lightweight concrete. This means that the formwork required is equally lightweight and simple for the mortar to install.
- Convenient for carriage in a few bags with just a bucket of water even on a large project site and for storage up to several hours in buckets with an air tight lid. Thus installers only need to do a number of small openings without having to repeat and consume time in preparing the mix at the site.
- Quick setting time in a few hours depending on ambient weather conditions.
- Easy to create new holes for installation of new penetrating services and equally easy to repair.
- Does not shrink on drying. For walls, if the opening is too large to be sealed, the void may need to be filled up to 90%. Let set for one hour, then fill remainder of void as the wet mortar slumping is under its own weight. This is not applicable in floors.
- Can be installed at the last minute before inspection time or after all services are installed.
- Comparatively more versatile and flexible to install, and more compatible with other Promat fire stopping systems.
- PROMASEAL® Mortar can provide a fully insulated system, depending on type and dimension of the penetrating services. Please consult Promat for details.

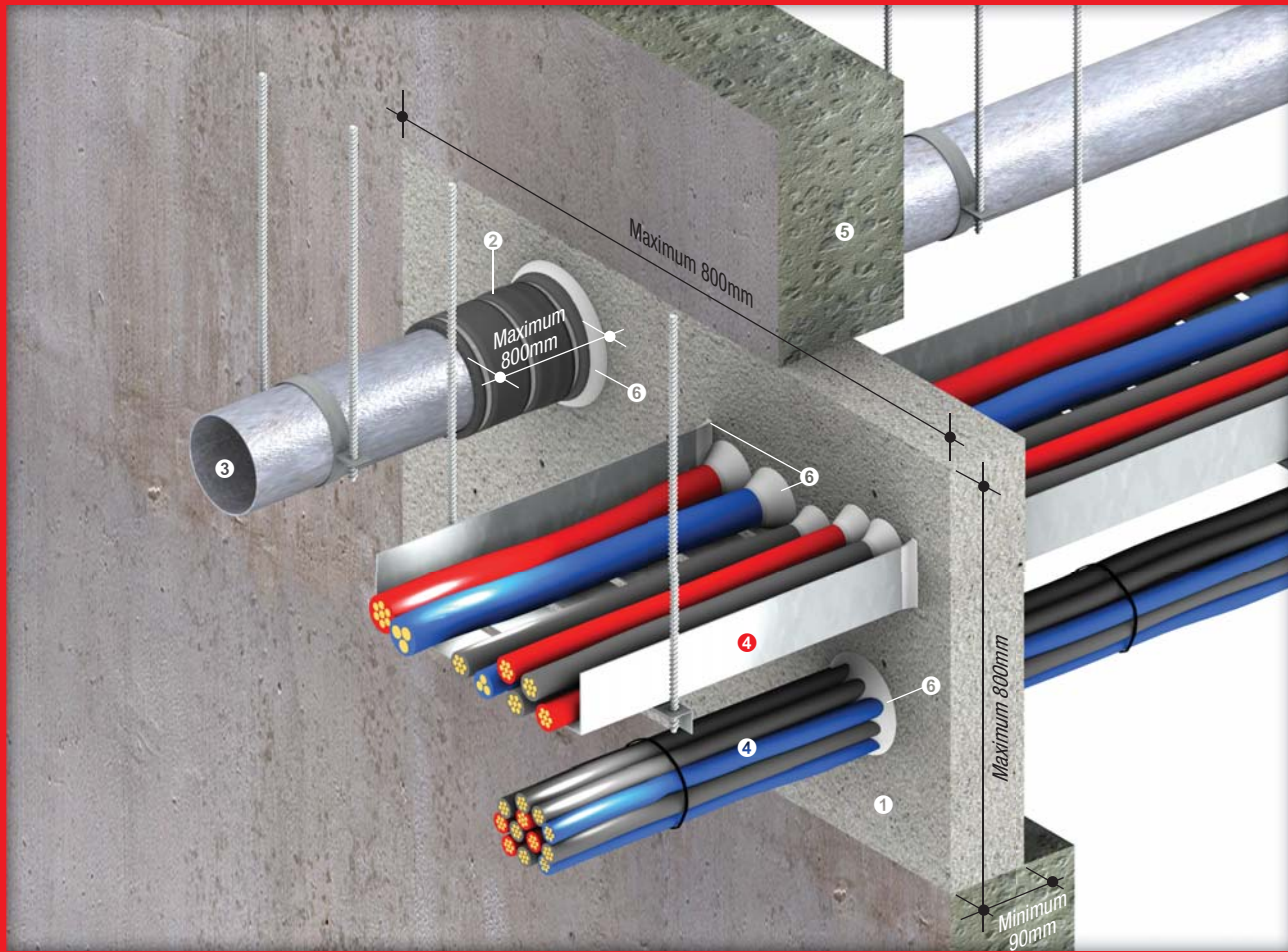

Up to -/240/240 fire resistance in accordance with the requirements of BS 476: Part 20: 1987, BS EN 1366: Part 3: 2009 and/or AS 1530: Part 4: 2005, depending on applications and types of penetrating elements; insulation time is the measured time to insulation failure on surface of the PROMASEAL® Mortar

In some instances, where insulation measured upon the penetrating elements is the required criteria, this time to insulation failure can be substantially shorter, e.g. metal pipes penetrating the walls. If insulation measured upon the penetrating elements is a specified performance criteria, please consult Promat about the use of PROMASEAL® Wrap

- | | |
|--|--|
| <ul style="list-style-type: none"> ❶ PROMASEAL® Mortar ❷ PROMASEAL® Wrap ❸ Non combustible metal pipes with appropriate support ❹ Electrical cables with or without supporting cable tray/steel trunking | <ul style="list-style-type: none"> ❺ Fire resistant concrete/masonry walls ❻ All joints and contact points caulked with PROMASEAL®-A Acrylic Sealant |
|--|--|

Applications that have been tested in floors or walls (with an equal or greater fire resistance level) are:

- Electrical cables in bundles or supported with steel cable trays through floors or walls;
- Steel and copper pipes up to 200mm nominal diameter in floors and up to 100mm in walls;
- Plastic pipes with non combustible mineral wool insulation in floors and walls;
- Hot and chilled water pipes with combustible insulation in floors (used in conjunction with PROMASEAL® FlexiWrap) and walls;
- Electrical busbars and busways in floors;
- uPVC electrical conduits in floors (used in conjunction with PROMASEAL® Conduit Collar);
- Telecommunication cables in floors and walls.

General Application Considerations

Please refer to the **General Application Considerations** on page 2 in conjunction with the following.

It is important that the user be aware of the type of penetrating services and the dimensions of the gaps that will be left around the services that are to be sealed. Valid supporting evidence that the proposal consists of a tested system may be required. This may vary from country to country; depending upon the way the test results are interpreted and how local regulations are applied.

Basic Handling Procedures

Mixing

PROMASEAL® Mortar is packed in bags, and is blended ready for mixing with water. When mixed with 12 to 16 litres of water, 20kg of the powder will produce approximately 35 litres of mix, this is sufficient to fill an area approximately 0.35m² at 100mm thickness (or 0.6m x 0.6m of clear opening).

For a dry “packing” mix, add PROMASEAL® Mortar to 10 litres of water.

For a medium mix, add PROMASEAL® Mortar to 12 litres of water.

For a wet “pourable” mix, add PROMASEAL® Mortar to 16 litres of water.

This equates to approximately 3 x 20kg bags of PROMASEAL® Mortar per 1m² of clear opening at 100mm thickness or approximately 30 bags per m³.

PROMASEAL® Mortar can be mixed to a consistency to suit the application. If services are close together and difficult to access, it may be necessary to make a wet “pourable” mix. If however the PROMASEAL® Mortar can be easily installed, make a medium mix. If the mortar has to be stacked in a wall opening, make a dry “packing” mix.

To assess such a dry mix, add sufficient water to create a mix that will, when squeezed, assume the shape and form of hand but will easily brush off without leaving hand wet (similar to damp sand on a beach, for example).

Bond Breakers To Metal Pipes

For some types of installation it may be necessary to allow for movement of services that pass through the seal, e.g. metal hot water pipes.

A bond breaker will then be required between the PROMASEAL® Mortar and the pipe. This can be achieved using a strip of 100mm x 10mm thick PROMASEAL® IBS™ wrapped around the pipe.

Sealing With PROMASEAL®-A Acrylic Sealant

Where cables penetrate the seal it may be necessary to apply sealant between the cables to ensure all gaps are sealed against the passage of fire and hot or cold smoke.

Where metal pipes penetrate the seal it is recommended that a fillet of PROMASEAL®-A Acrylic Sealant is applied around the pipe on the unexposed face to give a smoke and water seal at this point. This is not necessary to achieve the fire resistance, although is advisable to ensure the system can provide a seal against the passage of cold smoke.

Formwork

Types Of Formwork

Virtually any type of material can be used as formwork, e.g. high density mineral wool, polystyrene, timber etc.

Formwork does not necessarily have to be removed after installation. In the event of a fire the formwork becomes sacrificial. However, if formwork is constructed from a material such as PU foam, it is advisable to remove the formwork once the mortar is cured to reduce hazards of flammability and toxic smoke production.

The following list of formwork types are suggestions only, the material to be used for formwork will depend on size of the openings, type and configuration of the penetrating services:

- Plasterboard;
- PROMATECT®-H, PROMATECT®-L, PROMATECT® 100 board;
- Medium and high density mineral/rock wool;
- Polystyrene foam approximately 50mm thick depending upon the span;
- Timber (e.g. plywood or MDF board);
- Sheet metal.

Installing Formwork

Where access is possible, formwork can be fixed to the soffit of a floor or to the face of a wall. Ensure that the formwork is secure and supported where necessary.

If working from above a floor, the formwork can be placed from the top and supported on a steel angle fixed to the inside edge of the floor. The angle does not need to be continuous. Use sufficient to support the formwork.

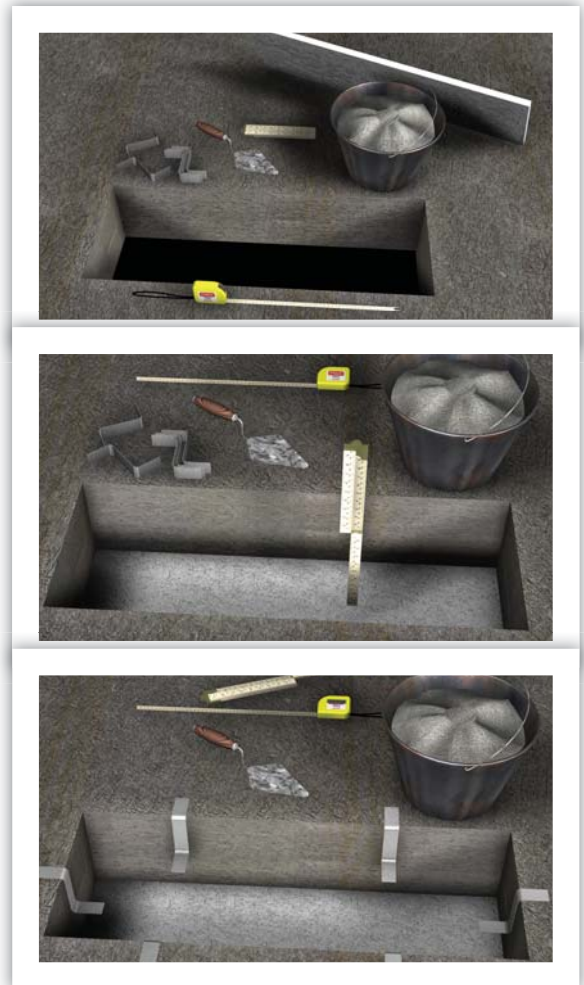

Alternatively, soft forms of formwork, e.g. mineral fibre battens, can be simply friction fitted into place. It is important to ensure the formwork is installed at the correct height to allow the the correct depth (105mm) of PROMASEAL® Mortar to be installed. Once the mortar is fully cured the formwork is sacrificial.

Sealing Formwork

All gaps around the perimeter or the services should be sealed to prevent wet slurry seeping through to the other side. This can be carried out using PROMASEAL®-A Acrylic Sealant or by placing a dry mix of mortar over the gaps.

Steel Z-Clips

Install steel Z-clips and/or angle brackets. These are critical to ensure an effective key into existing concrete/masonry floors. In certain situations (generally where a cable tray is adjacent to a vertical wall as shown on page 50), the clips are only required on three sides of the opening. An alternate method to applying steel Z-clips is to use a mechanical interlock where holes are drilled into the existing concrete element which meets the new PROMASEAL® Mortar, so that the fresh mortar can flow into that and key it back to the surrounding element.

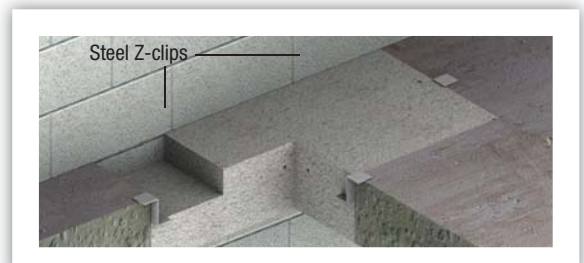

Every application may need a slightly different approach and solution. The following are basic guidelines only.

PROMASEAL® Mortar is non loadbearing. It is advisable to place a visible warning sign near all barriers to identify its characteristics/inherent properties, with wording similar as follows:

WARNING: THIS IS A FIRE RESISTANT BARRIER. DO NOT DISTURB. DO NOT WALK OR PLACE ANY LOADS ON OR AGAINST THE BARRIER. IF THE BARRIER IS DAMAGED CONTACT (name of installer) IMMEDIATELY.

Installation

Penetration Seals In Concrete/Masonry Floors

Depth of PROMASEAL® Mortar required

For floors a minimum 105mm thick PROMASEAL® Mortar is required for fire resistance performance up to 240 minutes and 70mm thick PROMASEAL® Mortar for up to 120 minutes.

The insulation measured on the individual penetrating services may have lesser fire resistance level. Please consult Promat for more information.

Cored holes

If the gap around any service is small, it may be possible to simply force a foam backing rod or styrene foam into place to act as formwork and then install the mortar. It is advisable to seal around services with a fillet of PROMASEAL®-A Acrylic Sealant to act as a barrier against the passage of smoke and water leakage in floors. This sealant is not required to meet fire performance requirements.

PROMASEAL® Pillows are normally a better option for this type of penetration. Please refer to [pages 56 and 57](#) for details.

Openings in service risers

Generally such openings have only three sides and are adjacent to a continuous vertical wall.

Once the formwork of choice is positioned and sealed, mix a wet slurry of PROMASEAL® Mortar and pour approximately 20mm over the entire surface of the formwork, taking care to achieve good coverage around and behind services, especially cables. When viewed from above, where gaps around perimeter edges and services exist, sealant or a drier mortar mix may be used to seal such gaps.

On the fourth side of the penetrations, where it is not possible to install steel Z-clips due to the position of the vertical wall, they can be omitted. Place the Z-clip formed angles into the opening at nominal 300mm centres. The angles to the vertical wall should be mechanically fixed using minimum 25mm nails or similar, the horizontal leg of the angle or Z-clip should sit approximately 50mm into the thickness of the PROMASEAL® Mortar.

The slurry will quickly set, in turn enabling a drier mix to be packed into position by hand. It is advisable to wear rubber gloves when handling the mortar material to prevent chapping or irritation of hands.

Pack the mix firmly to the top of the slab and trowel off to provide a neat finish. It is necessary to seal around services with a fillet of PROMASEAL®-A Acrylic Sealant to seal against the passage of smoke and water leakage in floors. The sealant should be applied in a cone "volcano" shape and should extend approximately 45mm along the service and 20mm onto the mortar element.

It is acceptable to apply dry mix directly to formwork as long as all gaps can be filled and the mortar penetrates between and around all services.

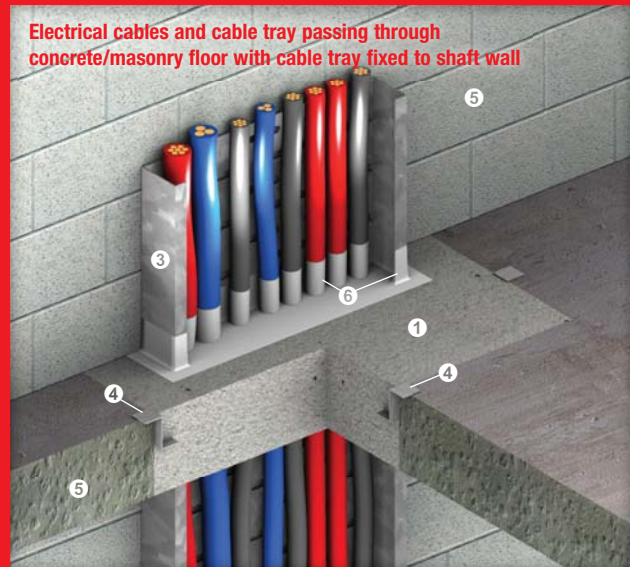
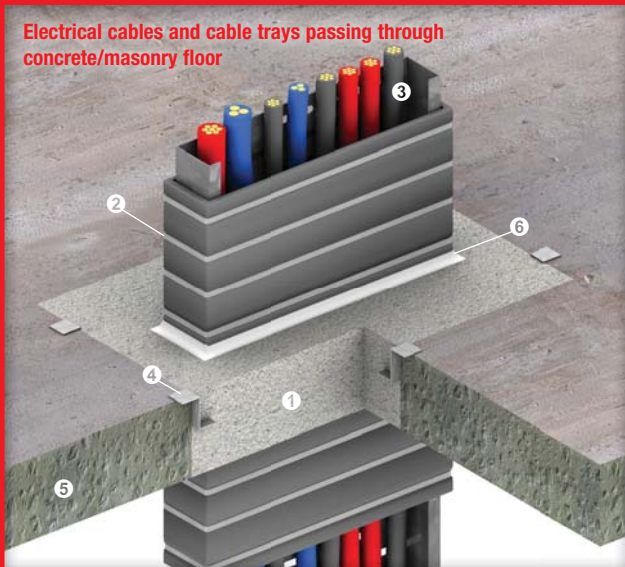

Up to -/240/180 fire resistance in accordance with the requirements of BS 476: Part 20: 1987, BS EN 1366: Part 3: 2009 and/or AS 1530: Part 4: 2005, depending on applications and types of penetrating elements; insulation time is the measured time to insulation failure on surface of the PROMASEAL® Mortar

In some instances, where insulation measured upon the penetrating elements is the required criteria, this time to insulation failure can be substantially shorter, e.g. metal pipes penetrating the walls. If insulation measured upon the penetrating elements is a specified performance criteria, please consult Promat

- ① PROMASEAL® Mortar
- ② PROMASEAL® Wrap
- ③ Electrical cables supported with cable tray or steel trunking
- ④ Steel Z-clips 25mm wide at nominal 300mm centres
- ⑤ Fire resistant concrete/masonry floors or walls
- ⑥ All joints and contact points caulked with PROMASEAL®-A Acrylic Sealant

Penetration Seals In Concrete/Masonry Walls

Depth of PROMASEAL® Mortar required

For walls a minimum 90mm thick PROMASEAL® Mortar is required for fire resistance performance up to 240 minutes.

The insulation measured on the individual penetrating services may have lesser fire resistance level. To combat this issue consider the use of PROMASEAL® Wrap. Please consult Promat for more information.

Cored holes

Clearances around services in cored holes are generally small, requiring a dry mix to be packed into the gap between the wall and the service. In such cases formwork may not be required.

Purpose made service openings

These may be pre-formed or may be holes that have been knocked through existing walls. If a neat, smooth finish is required, formwork should be attached to one face of the wall over the opening. Trim the formwork around the service. It is not necessary to make the formwork fit tightly around services.

For wall applications, a dry "packing" mix should be used. Stack the mortar into the opening; it should be possible to stack the mortar to a height of 600mm at one time if the mix is correct consistency. It may be necessary to fill in along the top of the opening after the mortar has settled and set. Any small openings around the edges or around services should be sealed with PROMASEAL®-A Acrylic Sealant.

Waterproofing

PROMASEAL® Mortar is porous. Its low density is one of the major reasons it is used on building and construction sites. If subjected to constant water coverage, water will pass through the mortar. If water resistance is required, the surface of the dry mortar must be sealed with a proprietary waterproof membrane or coating.

It would be prudent to prepare a sample area for testing to ensure the membrane or coating is suitable for use in terms of its compatibility with the PROMASEAL® Mortar and that the membrane/coating will provide sufficient durability to meet installation requirements. As always, the membrane/coating manufacturer's instructions should be followed precisely.

Surface hardening

Hardening is not a usual requirement. However, in some floor applications where small cored holes may have to be sealed, it may be necessary. This is frequently the case in office areas where equipment is being installed and may thus necessitate surface hardening.

In such instances, apply a proprietary brand cementitious, non shrink grout to the surface of the PROMASEAL® Mortar that will set into a hard surface. At all times, follow the manufacturer's instructions.

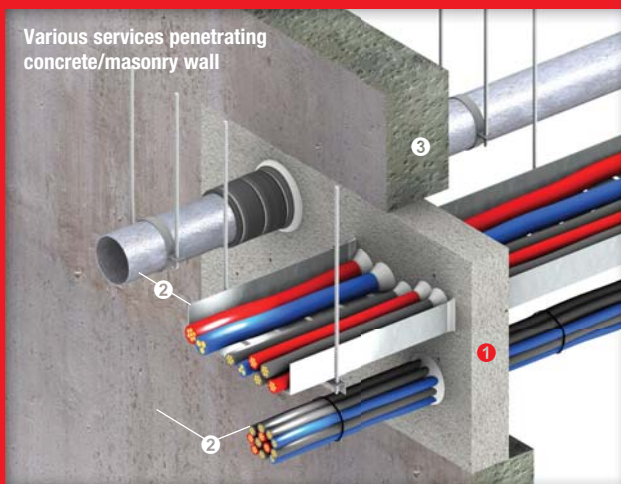
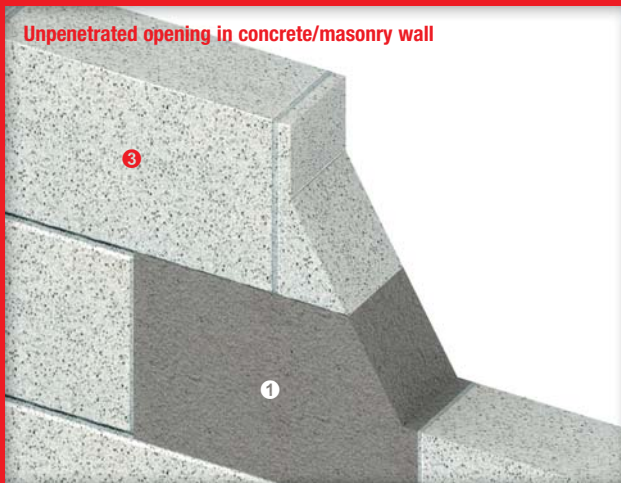

Up to ~240/120 fire resistance in accordance with the requirements of BS 476: Part 20: 1987, BS EN 1366: Part 3: 2009 and/or AS 1530: Part 4: 2005, depending on applications and types of penetrating elements; insulation time is the measured time to insulation failure on surface of the PROMASEAL® Mortar

In some instances, where insulation measured upon the penetrating elements is the required criteria, this time to insulation failure can be substantially shorter, e.g. metal pipes penetrating the walls. If insulation measured upon the penetrating elements is a specified performance criteria, please consult Promat about the use of PROMASEAL® Wrap

- ① PROMASEAL® Mortar
- ② Various penetrating services (see page 48 for details)
- ③ Fire resistant concrete/masonry walls

Control Joint Seals

Openings in concrete/masonry floors

Floor openings in excess of 0.64m² must include control joint seals.

If an opening is less than 600mm long but greater than 400mm in width for the PROMASEAL® Mortar, apply PROMASEAL®-A Acrylic Sealant in all gaps and joints across the opening so that each section of the mortar is no greater than 0.64m² in area.

If an opening is greater than 600mm wide and exceeding 400mm in length, install the PROMASEAL® Mortar with supporting steel angles as illustrated in **Detail 1** below.

Openings in concrete/masonry walls

Wall openings in excess of 0.64m² must include control joint seals.

If an opening is less than 600mm high but greater than 600mm in width for the PROMASEAL® Mortar, use a PROMATECT®-H strip as illustrated in **Detail 2** below.

If an opening is greater than 600mm wide and exceeding 600mm in height, use supporting steel angles placed horizontally and a PROMATECT®-H strip filled with PROMASEAL®-A Acrylic Sealant for vertical joints.

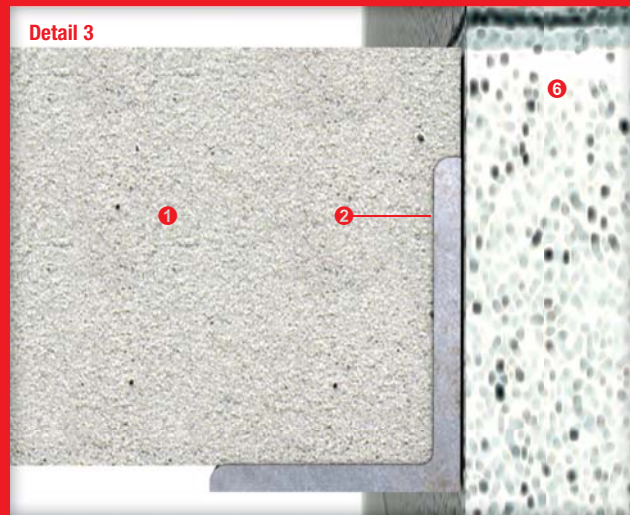
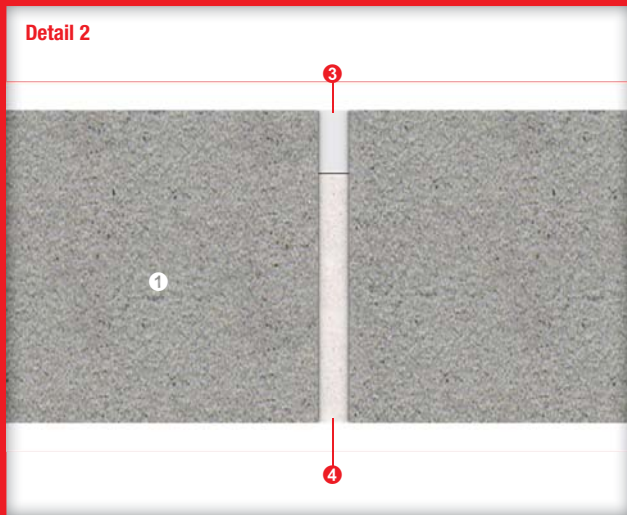
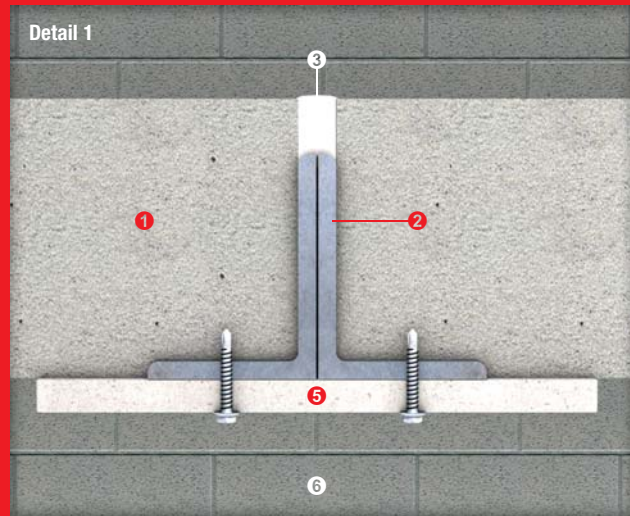
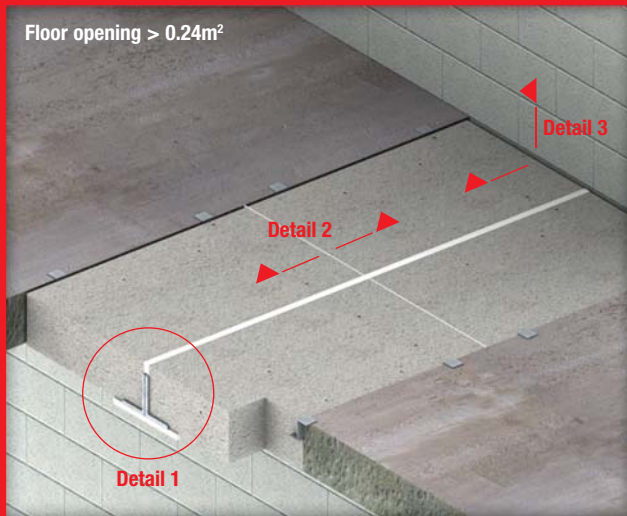

Up to -/240/240 fire resistance in accordance with the requirements of BS 476: Part 20: 1987, BS EN 1366: Part 3: 2009 and/or AS 1530: Part 4: 2005, depending on applications and types of penetrating elements; insulation time is the measured time to insulation failure on surface of the PROMASEAL® Mortar

In some instances, where insulation measured upon the penetrating elements is the required criteria, this time to insulation failure can be substantially shorter, e.g. metal pipes penetrating the walls. If insulation measured upon the penetrating elements is a specified performance criteria, please consult Promat about the use of PROMASEAL® Wrap

- ① PROMASEAL® Mortar
- ② Galvanised steel angles, dimension in accordance with the floor opening as follows, welded together or screwed back to back:
100mm x 75mm x 8mm thick for < 1.8m² of span
100mm x 100mm x 8mm thick for 1.8-2.4m² of span
Please consult Promat for spans > 2.4m²
- ③ PROMASEAL®-A Acrylic Sealant 20mm thick filled into the joint
- ④ PROMATECT®-H strips 9mm thick cast within the mortar
- ⑤ PROMATECT®-H strips 280mm wide, thickness in accordance with the required fire resistance as follows fixed to ② using minimum 100mm long self-tapping screws at nominal 200mm centres:
9mm thick for -/60/60 fire resistance
20mm thick for -/90/90 fire resistance
25mm thick for -/120/120 fire resistance
35mm thick for -/180/180 fire resistance
45mm thick for -/240/180 fire resistance
- ⑥ Fire resistant concrete/masonry floors or walls

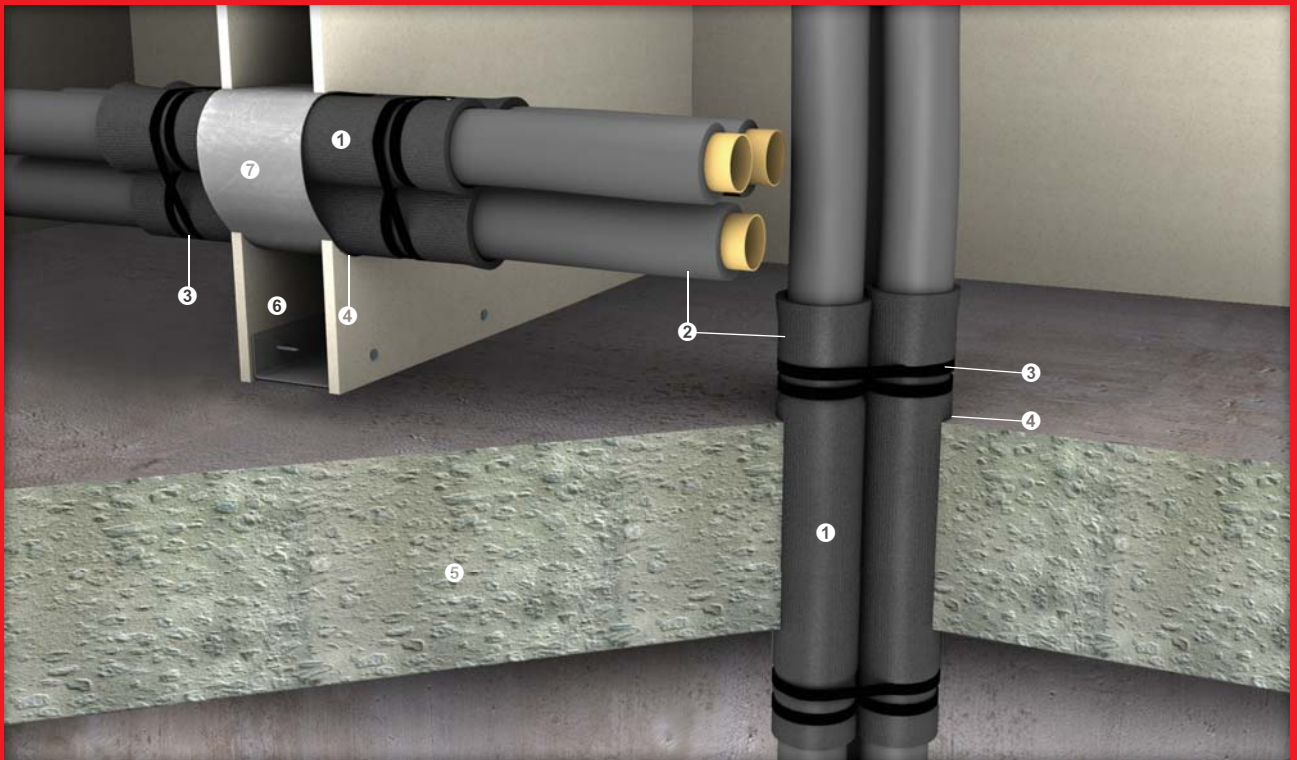

Up to -/240/120 fire resistance in accordance with the requirements of BS 476: Part 20: 1987 and/or AS 1530: Part 4: 2005, depending on applications and types of penetrating elements

- ① PROMASEAL® FlexiWrap
- ② Combustible copper pipes with insulation layers
- ③ General electrical cable ties
- ④ All joints and contact points (in close fit openings) caulked with PROMASEAL®-A Acrylic Sealant to prevent cold smoke ingress and water passage from natural building or thermal movement
- ⑤ Fire resistant concrete/masonry floors
- ⑥ Fire resistant steel/timber framed lightweight partitions
- ⑦ Where a cavity exists at which the PROMASEAL® FlexiWrap passes through a wall/partition, mild steel closers should be wrapped around the FlexiWrap to prevent the intumescent product falling into the cavity when exposed to fire

PROMASEAL® FlexiWrap is manufactured with Promat intumescent technology. It is designed to provide fire resistance where combustible insulation is used as thermal insulation around metal pipes.

PROMASEAL® FlexiWrap has been tested up to 240 minute fire resistance with copper pipes through concrete/masonry floors and walls or lightweight partitions (with an equal or greater fire resistance level) where they are generally combustible and potential for fire, hot gases and smoke to bypass the compartmentation. It is not applicable on plastic pipes.

PROMASEAL® FlexiWrap is supplied in 850mm x 450mm forms.

Installation

Installation in concrete/masonry floors

For penetration seals of groups of copper pipes with combustible lagging passing through a concrete/masonry floor, the following should be observed:

- Individually wrap each pipe with one layer of PROMASEAL® FlexiWrap. These wraps should protrude a minimum of 50mm from the upper and lower surface of the floor. To ensure the FlexiWrap stays in place and secured with general electrical cable ties in four locations, i.e. one at each side of the penetration and two within the depth of the penetration.
- Once wrapped, the pipes should be backfilled with PROMASEAL® Mortar.

- Maximum dimension for a floor penetration is 600mm x 400mm; multiple penetrations are allowed. For openings greater than 600mm x 400mm, please consult Promat.

Installation in concrete/masonry walls

For penetration seals of groups of copper pipes with combustible lagging passing through a concrete/masonry wall, the following should be observed:

- Individually wrap each pipe with one layer of PROMASEAL® FlexiWrap. These wraps should protrude a minimum of 50mm from both sides of the wall, or a minimum of 75mm if the wall is less than 100mm thick. To ensure the FlexiWrap stays in place and secured with general electrical cable ties in four locations, i.e. one at each side of the penetration and two within the depth of the penetration.
- For cavity walls, mild steel closers should be wrapped around the PROMASEAL® FlexiWrap to prevent the intumescent product falling into the cavity when exposed to fire.
- Once wrapped, the pipes should be backfilled with PROMASEAL®-A Acrylic Sealant, PROMASEAL® Mortar or other Promat fire stopping products depending on the dimension of the opening.
- Maximum opening dimension is 600mm x 600mm. Multiple penetrations are allowed.

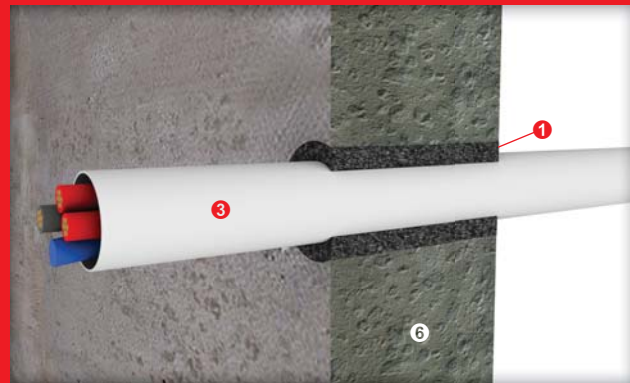
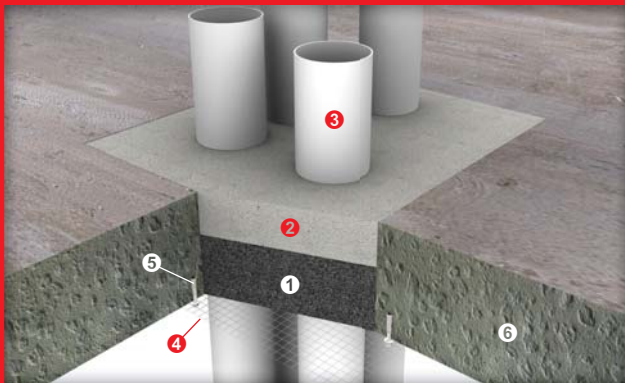

Up to -/240/120 fire resistance in accordance with the requirements of BS 476: Part 20: 1987 and/or AS 1530: Part 4: 2005, depending on applications and types of penetrating elements

- ❶ PROMASEAL® Grafitex
- ❷ PROMASEAL® Mortar
- ❸ uPVC plastic piping
- ❹ Steel perforated mesh 1mm thick with 4mm holes
- ❺ 25mm long steel anchors at nominal 150mm centres
- ❻ Fire resistant concrete/masonry floors or walls

Guide of sectional surface area of pipes

Pipe size (Ø mm)	x 1	x 2	x 3	Holes (mm)	Ø mm ²	mm ²
40	1257	2514	3771	100	7854	10000
50	1964	3928	5892	150	17672	22500
65	3319	6638	9957	200	31416	40000
80	5027	10054	15081	250	49088	62500
100	7854	15708	-	300	70686	90000

PROMASEAL® Grafitex is an intumescent compound unaffected by water and moisture when cured. It is designed to expand and fill the gaps around the penetrating services when exposed to fire and any that may occur at where combustible type services melt or distort.

In general PROMASEAL® Grafitex is used in lieu of a fire resistant sealant where a penetrating service insulated by combustible materials or the service itself is combustible, e.g. uPVC conduits. It is not applicable for metal services or electrical cables. For these applications, please refer to PROMASEAL®-A Acrylic Sealant (pages 28 to 32), PROMASEAL® IBS™ (pages 35 to 37) or PROMASEAL® Mortar (pages 47 to 51).

PROMASEAL® Grafitex is not designed for use in gaps or joints where a high degree of thermal movement is expected.

General Application Considerations

Please refer to the **General Application Considerations** on page 2 in conjunction with the following.

It is important that the user be aware of the type of services and the dimensions of the gaps that will be left around the services that are to be sealed. Valid supporting evidence that the proposal consists of a tested system may be required. This may vary from country to country, depending upon the way the test results are interpreted and how local regulations are applied. Applications that have been tested in concrete/masonry floors and walls (with an equal or greater fire resistance level) include:

- Up to 120 minutes for multiple pipe penetrations, i.e. cluster of uPVC pipes of 50mm, 80mm and 100mm nominal diameters through floors;
- Up to 120 minutes for plastic pipes of 19mm nominal diameter insulated with 10mm combustible insulation through walls;
- Up to 120 minutes for XLPE pipes of 32mm nominal diameter through walls;
- Up to 120 minutes for pipes of 19mm nominal diameter with "Kemlag" combustible (thin rubber) insulation through walls;
- Up to 120 minutes for 25mm uPVC conduits of 25mm nominal diameter through walls;
- Up to 120 minutes for conduits of 40mm nominal diameter through floors;
- Up to 240 minutes PPR pipes of 32mm nominal diameter passing through floors;
- Up to 240 minutes for uPVC conduits of 25mm and 40mm nominal diameters through walls.

Installation

Multiple pipes passing through floors

The total cross sectional surface area of the pipes penetrating the floor must be no greater than half of the cross sectional surface area of the opening and no greater than 17500mm². Please refer to table above.

Steel perforated mesh (4mm holes) 1mm thick must be fixed to the soffit of the floor around the pipes. The mesh should be overlapped onto the floor by a minimum 30mm to allow proper and adequate fixing. Fix to the floor using 25mm long steel anchors at nominal 150mm centres. PROMASEAL® Grafitex is poured onto the mesh to a depth of 90mm. Any remaining space between the top of the Grafitex and top surface of the floor can be leveled off using PROMASEAL® Mortar or other commercial grade mortar mix.

Metal pipes passing through floors and walls insulated with combustible lagging

PROMASEAL® FlexiWrap is the usually ideal for this application. However, there may be situations that demand the use of PROMASEAL® Grafitex.

Where combustible insulation passes through floors or walls with gaps between the insulation and the surrounding building element, one method of maintaining the compartmentation is to pack PROMASEAL® Grafitex across the full depth of the opening. The minimum allowable gap width is 15mm.

Maximum nominal diameter of metal (steel or copper) pipe is 100mm.

Others

For 19mm metal pipes insulated with combustible insulation, 32mm XLPE pipes and 19mm metal pipes with "Kemlag" insulation, or 25mm uPVC conduits and 40mm uPVC conduits passing through walls.

Install PROMASEAL® Grafitex between the insulation or the pipe and the wall to a minimum depth of 32mm on both sides of the wall to a maximum gap width of 10mm.

For use of PROMASEAL® Grafitex around 40mm uPVC conduits, the wall must be no greater than 90mm in overall thickness and the gaps between the pipe and the wall a maximum of 15mm. Install the Grafitex to the full depth of the wall or to a minimum of 50mm depth, positioned at the centre of the wall thickness.

On occasions there may not be sufficient space to install an intumescent collar. In some instances, it may be possible to use PROMASEAL® Grafitex. Please consult Promat for more information.

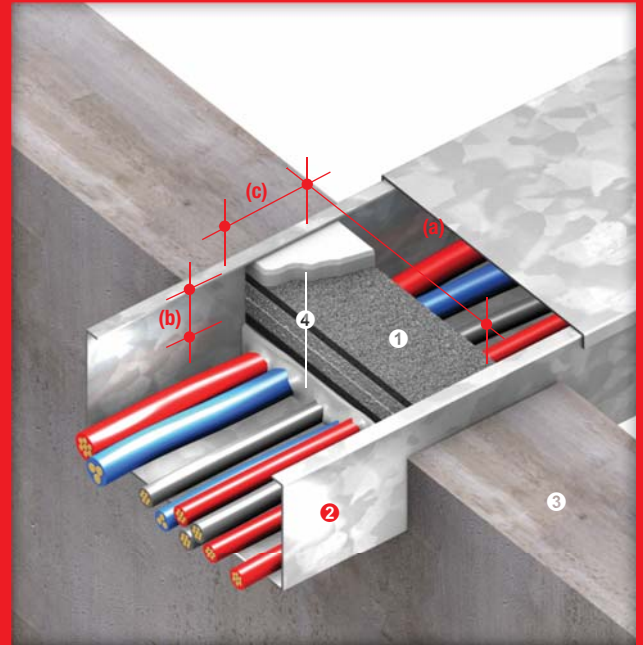
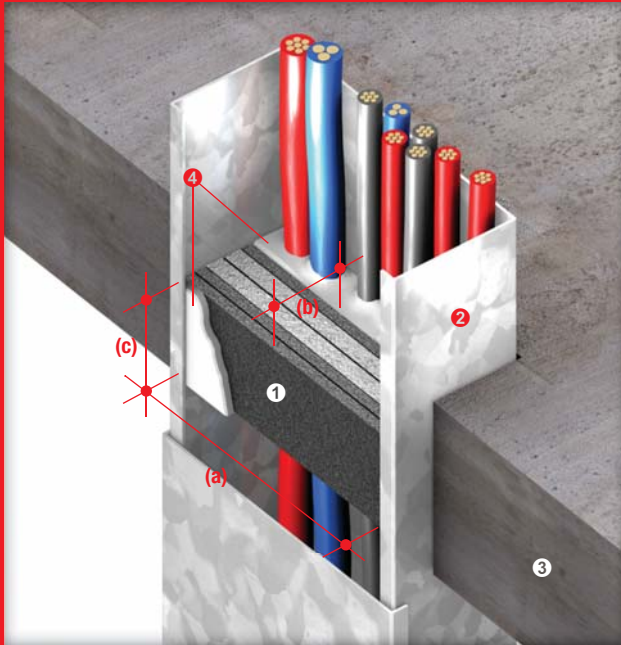

Up to -/120/120 fire resistance in accordance with the requirements of BS 476: Part 20: 1987, and up to -/120/- fire resistance in accordance with the requirements of AS 1530: Part 4: 2005

- ① PROMASEAL® Electrical Junction Seal
- ② Electrical cables supported with cable tray or steel trunking
- ③ Fire resistant concrete/masonry floors or walls
- ④ All gaps (between the electrical cables, beneath or between lid and top of the PROMASEAL® Electrical Junction Seal) caulked with PROMASEAL®-A Acrylic Sealant to achieve the required fire resistance performance

Measurement of PROMASEAL® Electrical Junction Seal (mm)			Measurement of steel trunking for electrical cables Width (mm) x Height (mm)
(a)	(b)	(c)	
100	35	84	100 x 100
150	50	84	150 x 150
200	50	84	200 x 200

PROMASEAL® Electrical Junction Seal consists of Grafitex intumescent strips, sandwiched between a special compressible foam. It is a system that will prevent the spread of fire when inserted to steel trunking supported electrical cables that pass through compartment floors and walls.

PROMASEAL® Electrical Junction Seal has been tested up to 120 minute fire resistance with electrical cable trunking in concrete/masonry floors or walls and lightweight partitions (with an equal or greater fire resistance level).

The electrical cable trunking must be within a maximum dimension of 200mm x 200mm and be constructed of minimum 0.5mm thick steel. All perimeter gaps around the outside between the trunking and the building element must be sealed.

When exposed to the heat from a fully developed fire, the Grafitex intumescent strips will expand to compress and eventually form a solid char plug around the electrical cables and inside the cable trunking, thus preventing the spread of fire along the cables and through the trunking.

PROMASEAL® Electrical Junction Seal is supplied in THREE (3) sizes to suit different electrical cable trunking sizes:

- 1) 100mm x 84mm x 35mm thick for cable trunking measuring 100mm x 100mm
- 2) 150mm x 84mm x 50mm thick for cable trunking measuring 150mm x 150mm
- 3) 200mm x 84mm x 50mm thick for cable trunking measuring 200mm x 200mm

Installation

Select a correct size of the PROMASEAL® Electrical Junction Seal to suit dimension of the electrical cable trunking. Position inside the trunking, central to the thickness of the floor/wall through which the trunking passes. Push the seal firmly onto the surface of the electrical cables within the trunking.

After installation there may be visible through gaps where adjacent cables are not tightly abutted. When exposed to fire these gaps will be sealed by the action of the intumescent seal. The system will not be adversely affected if it is felt that a particular installation should have such gaps sealed with a bead of PROMASEAL®-A Acrylic Sealant. Indeed, this would enhance the performance of the system by providing a seal against the passage of cold smoke.

Where gaps occur between the top of the seal and the underside of the trunking lid, these will close on expansion of the intumescent material when exposed to fire. If required, additional layers of PROMASEAL® Electrical Junction Seal or PROMASEAL®-A Acrylic Sealant can be positioned to close such gaps without adversely affecting the performance of the system.

Any gaps up to 20mm between the electrical cable trunking and building element through which it passes, must be sealed in an approved manner.

The application of PROMASEAL®-A Acrylic Sealant to a depth of 16mm (for 60 minute fire resistance) and 32mm (for 120 minute fire resistance) will suffice. The sealant should be applied to the side of the building element exposed to fire. In most cases, this mean the underside of a floor and both sides of a wall. Gaps over 20mm should be sealed with a suitably tested system or the building element must be reinstated.

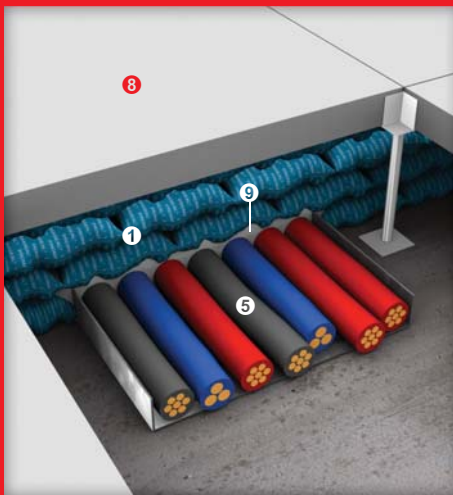
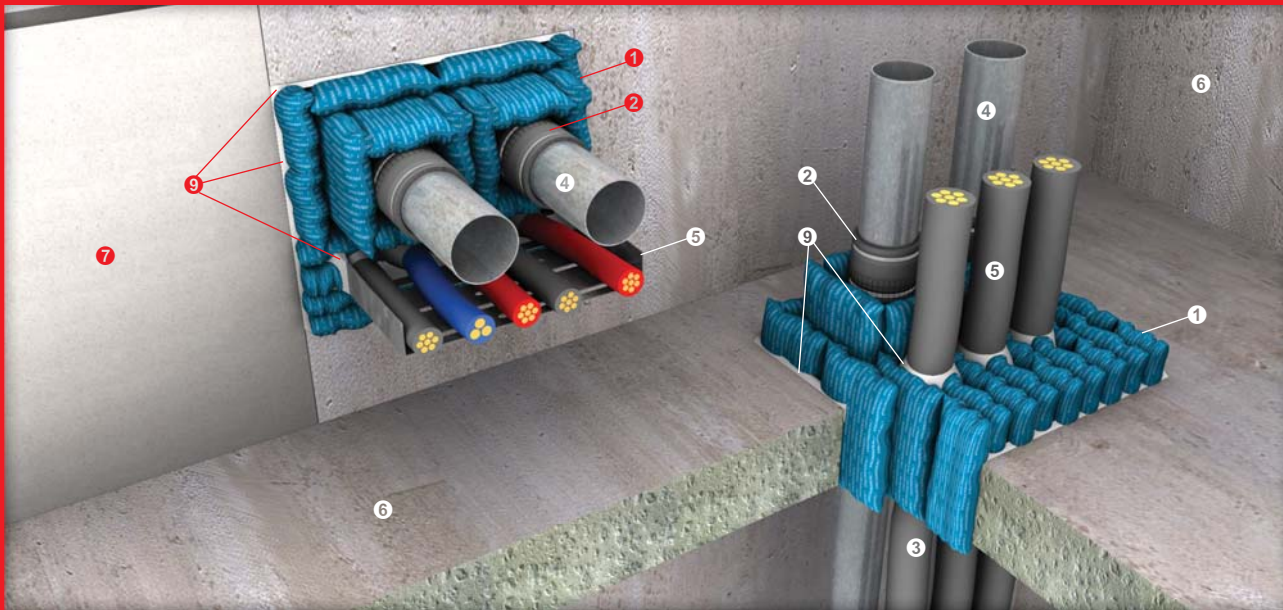

Up to -/180/180 fire resistance in accordance with the requirements of BS 476: Part 20: 1987, BS EN 1366: Part 3: 2009 and/or AS 1530: Part 4: 2005, depending on applications and types of penetrating elements; insulation time is the measured time to insulation failure on surface of the PROMASEAL® Pillows

In some instances, where insulation measured upon the penetrating elements is the required criteria, this time to insulation failure can be substantially shorter, e.g. metal pipes penetrating the floors or walls. If insulation measured upon the penetrating elements is a specified performance criteria, please consult Promat about the use of PROMASEAL® Wrap or extra large PROMASEAL® Pillows (nominal 250mm x 600mm x 40mm thick)

- 1 PROMASEAL® Pillows
- 2 PROMASEAL® Wrap
- 3 Optional steel wire mesh to support the pillows in a horizontal orientation
- 4 Non combustible metal pipes
- 5 Electrical cables with or without supporting cable tray/steel trunking
- 6 Fire resistant concrete/masonry floors or walls
- 7 Fire resistant steel/timber framed lightweight partitions
- 8 Fire resistant raised access floors
- 9 All joints and contact points caulked with PROMASEAL®-A Acrylic Sealant to prevent cold smoke ingress and water passage from natural building or thermal movement

PROMASEAL® Pillows are manufactured from treated cloth filled with a high density, granulated fire seal mineral wool. When exposed to fire, the pillows remain in place and char, thus forming a fire barrier of a solid mass of insulating material.

If theory, PROMASEAL® Pillows are probably the simplest of all Promat fire stopping products to use. They are one of the most economic products if material costs alone are factored into usage/purchase and scale of budget decisions.

Pillows are expensive because between 100mm and 130mm are needed for every square metre of open area. But they are very easy to install and can be placed in many openings where it would be impossible to install other products. Often it is economical to use this system only because few pillows may be required to achieve the appropriate performance requirements, especially if labour costs can be kept low.

PROMASEAL® Pillows have been tested up to 180 minutes with various penetrations seals in concrete/masonry floors or walls and lightweight partitions (with an equal or greater fire resistance level).

In many buildings, power cables are continuously added and removed, typical are telecommunication and information technology cables. PROMASEAL® Pillows enable this process to be carried out with the minimum of mess and inconvenience. It is a simple matter to thread a new cable through a PROMASEAL® Pillows system and then re-seal using PROMASEAL®-A Acrylic Sealant.

If pillows need to be removed (e.g. for retrofitting of services), empirical evidence suggests that many authorities are opposed to the use of pillows simply because they are concerned that the pillows will not be correctly replaced after rectification work is completed.

There is understandable concern and it is also quite common for authorities to insist on the pillows being physically held in place with steel mesh to prevent removal. Another method is to apply a coating of PROMASEAL®-A Acrylic Sealant in a thin film over the surface of the pillows. This is seen to at least be a warning to people that the pillows are there for a reason. It also makes them more difficult to remove and makes it easier to observe when they have been removed and not replaced correctly.

Promat recommends a nominal 1-2mm thick of PROMASEAL®-A Acrylic Sealant to be brush applied over the surface of the pillows after they are installed.

PROMASEAL® Pillows are non loadbearing. It is advisable to place a visible warning sign near all barriers to identify its characteristics/inherent properties, with wording similar as follows:

WARNING: THIS IS A FIRE RESISTANT BARRIER. DO NOT DISTURB. DO NOT WALK OR PLACE ANY LOADS ON OR AGAINST THE BARRIER. IF THE BARRIER IS DAMAGED CONTACT (name of installer) IMMEDIATELY.

It is important that the user be aware of the type of services and the dimensions of the gaps that will be left around the services that are to be sealed. Valid supporting evidence that the proposal consists of a tested system may be required. This may vary from country to country, depending upon the way the test results are interpreted and how local regulations are applied. Applications that have been tested in concrete/masonry floors or walls and lightweight partitions (with an equal or greater fire resistance level) include:

- Electrical cables in bundles or supported with steel cable tray;
- Copper, brass and steel pipes up to 150mm nominal diameter;
- Telecommunication cables;
- Electrical busbar (through floors only).

General Application Considerations

PROMASEAL® Pillows can be used as a temporary measure during construction or where buildings have been fully or partially occupied or where fit out work is continuing or has to be carried out, and when authorities insist that compartmentation is maintained during this period. PROMASEAL® Pillows can also be used as a permanent barrier.

PROMASEAL® Pillows are used around services that penetrate floor and wall barriers through oversize openings that are too large to be sealed with PROMASEAL®-A Acrylic Sealant.

This is generally the case when a wall or floor has not been neatly cored for services to pass through and a large opening remains. Such openings must be correctly reinstated to maintain the fire resistance of the floor or wall.

A typical application is within a floor in service shafts. If the service shaft is not fire resistant and does not have fire resistant doors at each level, then the floor itself must be sealed at each level. Usually PROMASEAL® Mortar will be used for such an application but on occasion PROMASEAL® Pillows are the better solution, primarily due to access problems.

PROMASEAL® Pillows are used in power stations and large industrial complexes where cables are carried *en masse* through service tunnels. In such areas of industrial activity, diligent observance and enforcement of regulations is understandable because the company as well as its insurer will have substantial financial exposure, not only on the building but also from business interruption that could follow an unconfined fire.

Applications are common in hospitals, care facilities for the aged and universities, especially if they operate laboratories. Services are generally directed along corridors, above ceilings and pass through fire resistant barriers above fire doors. It is difficult to reinstate block work around the services and the use of PROMASEAL® Mortar often proves to be too awkward in these situations.

The opening may be reduced in size using PROMASEAL® Mortar or with the same material that has been used for the wall, e.g. bricks or lining boards, but where the final sealing around the services would be too difficult to realise with other products, PROMASEAL® Pillows are an effective solution.

PROMASEAL®-A Acrylic Sealant will be needed to ensure that gaps around and between services, and close to walls are sealed.

For steel or timber framed lightweight partitions, the number of services passing through the opening can mean that the board installer will not be able to reinstate the lining close enough to the services to allow the use of PROMASEAL®-A Acrylic Sealant alone. In this type of construction, PROMASEAL® Pillows are one of the most economical methods of sealing the opening.

PROMASEAL® Pillows are especially useful under computer flooring where masses of electrical cables not only often pass through or beneath compartment walls but are frequently subject to change.

Installation

Penetration seals in concrete/masonry floors

The basic PROMASEAL® Pillows sealing system is up to 180 minute fire resistance performance when applied to unpenetrated situations

in floors. Various types of service penetrations have been evaluated within the system and achieve a range of fire resistance levels. Please consult Promat for full information.

Maximum dimension for floor openings is 0.25m² or 500mm x 500mm. If the height is less than 180mm, the width of the opening can be unlimited. For openings greater than these dimensions, either use PROMASEAL® Mortar or fix a structural element across the opening to create apertures of acceptable dimensions. If this structural member is formed from a steel member, it may also need fire protection. To provide protection to the steel member, calculate its Hp/A and protect with PROMATECT®-H, PROMATECT®-L, or PROMATECT® 100 boards.

PROMASEAL® Pillows must be very tightly packed into openings, starting at one edge and moulded to overhang the perimeter of the floor slab for support. Place the PROMASEAL® Pillows along one full side of the opening and gradually work into the centre of the opening. All subsequent layers of PROMASEAL® Pillows must be staggered (overlapped), similar in manner to the way bricks or blocks are laid. Ensure the pillows are packed very firmly into position, using a rubber or wooden mallet or similar implement.

Ensure all gaps near the services or edge of the penetration are fully and properly sealed with PROMASEAL®-A Acrylic Sealant.

To prevent removal of the pillows, it is recommended to seal the top side of the installed pillows with 1-2mm of PROMASEAL®-A Acrylic Sealant or fix a wire mesh under the floor opening.

Penetration seals in concrete/masonry walls

The basic PROMASEAL® Pillows sealing system is up to 180 minute fire resistance performance when applied to unpenetrated situations in floors. Various types of service penetrations have been evaluated within the system and achieve a range of fire resistance levels. Please consult Promat for full information.

Maximum dimension for wall openings is up to 1000mm wide x 600mm high. If the height is less than 180mm, the width can be unlimited. For openings greater than these dimensions, either use PROMASEAL® Mortar or fix a structural element across the opening to create apertures of acceptable dimensions. If this structural member is formed from a steel member, it may also need fire protection. To provide protection to the steel member, calculate its Hp/A and protect with PROMATECT®-H, PROMATECT®-L or PROMATECT® 100 boards.

PROMASEAL® Pillows must be very tightly packed into openings, starting at the bottom and ensuring the pillows overhang both sides of the wall. All subsequent layers of PROMASEAL® Pillows must be staggered (overlapped), similar in manner to the way bricks or blocks are laid. Ensure the pillows are packed very firmly into position, using a large rubber or wooden mallet or similar implement.

Ensure all gaps near the services or edge of the penetration are fully and properly sealed with PROMASEAL®-A Acrylic Sealant.

In steel or timber framed lightweight walls, the edges of the wall lining around the opening must be restrained by trimming out with additional framing and lining.

To prevent removal of the pillows, it is recommended to seal the top side of the installed pillows with 1-2mm of PROMASEAL®-A Acrylic Sealant or fix a wire mesh over the wall opening.

Use of extra large PROMASEAL® Pillows and mesh guard

Where cable trays or bunches of cables pass through fire resistant barriers, extra large PROMASEAL® Pillows can be used directly in contact with the penetrating services to provide insulation criteria as well as integrity. The pillows need to be held on to the services with metal straps. If the opening is larger, other size pillows can be used to fill in the rest of the opening. For other services such as metal pipes, it is advisable to use PROMASEAL® Wrap.

Alternatively, a mesh guard can be applied to cable trays or bunches of cables. The guard will need to be kept 50mm away from the services at the following lengths: 100mm for cable trays, 100-150mm for steel pipes and 150-500mm for copper pipes.



Up to -/120/120 fire resistance in accordance with the requirements of BS 476: Part 20: 1987 and/or AS 1530: Part 4: 2005

- ❶ PROMASEAL® Switchbox Intumescent, inserted as illustrated below (left to right)
- ❷ Steel electrical switchbox minimum 72mm x 72mm x 35mm
- ❸ Electrical cables
- ❹ Switchbox socket outlets
- ❺ Fire resistant lightweight partitions (or masonry walls)

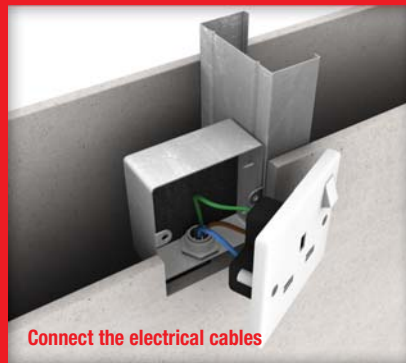

Separating walls form a fire barrier between compartments. However, recessed switchboxes often need to be installed in fire resistant dry wall or masonry structures. These recessed installations jeopardise the fire barrier function of the compartment wall.

Standard switch boxes also compromise the fire resistance of walls. When incorporated with the PROMASEAL® Switchbox Intumescent, these switchboxes provide fire resistant performance that maintains the integrity of the compartment wall in which they are installed.

PROMASEAL® Switchbox Intumescent has been tested up to 120 minute fire resistance in masonry walls and lightweight partitions (with an equal or greater fire resistance level).

During a fire, the switchbox plate will disintegrate causing fire to enter the dry wall cavity, resulting in premature failure. The fire resistant intumescent pad expands when this happens, creating an effective seal against ingress of fire and heat, thus preserving the fire resistant performance of the dry wall construction.

PROMASEAL® Switchbox Intumescent is supplied as pads in modules of 70mm x 70mm x 8mm thick. Other dimensions are available upon request.

PROMASEAL® Switchbox Intumescent is generally available through specialist electrical equipment suppliers only. Please contact Promat for details of local stockists.

For latest information of the Promat Asia Pacific organisation, please refer to www.promat-ap.com.

ASIA PACIFIC HEADQUARTERS

Promat International (Asia Pacific) Ltd.

Unit 19-02-01, Level 2, Wisma Tune
No.19 Lorong Dungun, Damansara Heights
50490 Kuala Lumpur
MALAYSIA
Tel: +60 (3) 2095 5111
Fax: +60 (3) 2095 6111
Email: info@promat-ap.com

AUSTRALIA

Promat Australia Pty. Ltd.

1 Scotland Road
Mile End South, SA 5031
Tel: 1800 PROMAT (776 628)
Fax: +61 (8) 8352 1014
Email: mail@promat.com.au

New South Wales Office

Promat Australia Pty. Ltd.

Unit 1, 175 Briens Road
Northmead, NSW 2152
Tel: 1800 PROMAT (776 628)
Fax: +61 (2) 9630 0258
Email: mail@promat.com.au

Victoria Office

Promat Australia Pty. Ltd.

Suite 205, 198 Harbour Esplanade
Docklands, VIC 3008
Tel: 1800 PROMAT (776 628)
Fax: 1800 334 598
Email: mail@promat.com.au

Queensland Office

Promat Australia Pty. Ltd.

1/68 Lisgar Street
Virginia, QLD 4014
Tel: 1800 011 376
Fax: 1800 334 598
Email: mail@promat.com.au

CHINA

Promat China Ltd.

Room 506, Block A, Qi Lin Plaza
13-35 Pan Fu Road
510180 Guangzhou
Tel: +86 (20) 8136 1167
Fax: +86 (20) 8136 1372
Email: info@promat.com.cn

Beijing Office

Promat North China

(Division of Promat China Ltd.)

Room 1507 Building 5, SOHO Xiandaicheng
No.88 Jianguo Road, Chaoyang District
100022 Beijing
Tel: +86 (10) 8589 1254
Fax: +86 (10) 8589 2904
Email: info@promat.com.cn

For Promat International and its worldwide group, see www.promat-international.com.

- The technical data provided in this publication is based on mean values prevalent at time of publication and is thus subject to fluctuation. It should not be regarded as a guarantee to system performance.
- All data contained herein conforms to and frequently surpasses generally accepted fire protection standards recognised by most professional fire science practitioners and regulatory authorities worldwide. The same general principle is equally applicable to all Promat products and systems. Promat has access to a considerable body of test authentication data and this can be provided on a complimentary basis upon request. It should be noted however that this publication replaces all previous editions in its entirety. Any form of reproduction by any means – manual, electronic, digital or otherwise – is strictly prohibited and subject to prior approval in writing from Promat. All rights related or connected to the Promat logo, Promat registered trademarks, featured illustrations, written information and technical reports in this publication are the sole, exclusive and copyright property of Promat and its legal partner companies.

HONG KONG

Promat International (Asia Pacific) Ltd.

Room 1010, C.C. Wu Building
302-308 Hennessy Road
Wanchai
Tel: +852 2836 3692
Fax: +852 2834 4313
Email: apromath@promat.com.hk

INDIA

Promat (Malaysia) Sdn. Bhd.

(India Representative Office)

610-611, Ansal Imperial Tower
C-Block, Community Centre
Naraina Vihar, Naraina
New Delhi 110028
Tel: +91 (11) 2577 8413
Fax: +91 (11) 2577 8414
Email: info-india@promat-asia.com

Bangalore Office

Promat (Malaysia) Sdn. Bhd.

(India Representative Office)

Cabin No. BC-10
Oculus Workspaces, No.66/1, 2nd Floor
Coles Road, Frazer Town
Bangalore 560005
Tel: +91 (80) 4031 4151
Fax: +91 (80) 4125 2135
Email: info-india@promat-asia.com

MALAYSIA

Promat (Malaysia) Sdn. Bhd.

Unit 19-02-01, Level 2, Wisma Tune
No.19 Lorong Dungun, Damansara Heights
50490 Kuala Lumpur
Tel: +60 (3) 2095 8555
Fax: +60 (3) 2095 2111
Email: info@promat.com.my

SINGAPORE

Promat Building System Pte. Ltd.

10 Science Park Road, #03-14 The Alpha
Singapore Science Park II
Singapore 117684
Tel: +65 6776 7635
Fax: +65 6776 7624
Email: info@promat.com.sg

SOUTH KOREA

Promat International (Asia Pacific) Ltd.

(Korea Branch Office)

Room 406, 811-2
Yeoksam-dong Gangnam-gu
Seoul 135080
Tel: +82 (70) 7794 8216
Email: apromath@promat.com.hk

Your local Promat supplier

